

2026



JBM®

SUA FERRAMENTA



7 CONJUNTOS DE FERRAMENTAS

CONJUNTOS DE FERRAMENTAS
 CONJUNTOS DE CHAVES DE CAIXA
 CAIXAS / MALETAS DE FERRAMENTAS
 CONJUNTOS DE PONTAS
 CONJUNTO DE CATRACAS MINI
 CONJUNTO DE ADAPTADORES
 KIT DE PONTAS
 KIT DE CHAVES DE CAIXA
 FERRAMENTAS COM ISOLAMENTO



37 FERRAMENTAS MANUAIS

CHAVES
 SARGENTOS
 CATRACAS
 CHAVES DINAMOMETRICAS
 BARRAS DE EXTENSÃO
 CHAVES DE FENDAS
 ALICATES
 FERRAMENTAS DE INSPEÇÃO
 MARTELOS
 FERRAMENTAS DE CORTE
 CINZEIS
 REBITADORES
 FERRAMENTAS DE MEDIÇÃO
 DIVERSOS



75 MOBILIÁRIO E EQUIPAMENTO PARA OFICINA

CONJUNTO DE MOBILIÁRIO
 CARRINHOS DE FERRAMENTAS
 MÓDULOS DE FERRAMENTAS
 MESAS DE TRABALHO
 ACESSÓRIOS DE MOBILIÁRIO
 COMPLEMENTOS AUXILIARES
 PAVIMENTAÇÃO



129 FERRAMENTAS ELÉTRICAS SEM FIO

20V

APARAFUSAR
 PERFURAR
 LIXAR/POLIR
 SERRAR
 FERRAMENTAS ESPECIAIS
 FERRAMENTAS DE JARDINAGEM
 BATERIAS / CARREGADORES

12V

APARAFUSAR
 PERFURAR
 LIXAR/POLIR
 SERRAR
 FERRAMENTAS ESPECIAIS
 BATERIAS / CARREGADORES



159 LUZES

LÂMPADAS DE INSPEÇÃO
 LANTERNAS DE CABEÇA
 GAMBIARRAS
 FOCOS LED
 ILUMINAÇÃO DE CAPÔ
 PIRILAMPOS
 LÂMPADA DE TRABALHO
 SINALIZAÇÃO
 ACESSÓRIOS E PEÇAS DE REPOSIÇÃO



175 FERRAMENTAS PNEUMÁTICAS

APARAFUSAR
 PERFURAR
 LIXAR/POLIR
 CORTAR / SERRAR
 PISTOLAS DE AR
 MANUTENÇÃO DE PNEUS
 OUTROS
 ENROLADORES DE MANGUEIRAS DE AR
 MANGUEIRAS CONECTORES
 ACESSÓRIOS E CONSUMÍVEIS



199 FERRAMENTAS DE IMPACTO

CHAVES DE CAIXA DE IMPACTO
ESPECIAL PNEUS
ADAPTADORES
PEÇAS SOBRESSALENTES
ESPECIAL CAMINHÕES



211 CARROÇARIA

FERRAMENTAS PARA CARROÇARIA
RESTAURAÇÃO DE FARÓIS
SUBSTITUIÇÃO DE VIDRO
REPARAÇÃO DO CHASSIS
MOBILIA AUXILIAR
CUIDADOS COM O VEÍCULO
DETAILING



231 TRAVÕES

REPOSICIONADORES
SANGRADORES DE TRAVÕES
MANUTENÇÃO



239 FERRAMENTA ESPECIAL

SISTEMA DE LUBRIFICAÇÃO
SISTEMA DE INJETORES
CILINDROS
EMBREAGEM
SISTEMA DE REFRIGERAÇÃO
SISTEMA DE AR CONDICIONADO
TRANSMISSÃO
SUSPENSÃO/DIREÇÃO
ESCAPE
SISTEMA ELÉTRICO
REPARAÇÃO DE ROSCAS
MOTOS
EXTRATORES
DESMULTIPLICADORES DE FORÇA



299 FERRAMENTAS DE SINCRONISMO

FIAT/ALFA ROMEO
BMW/MINI
PSA
FORD
JAGUAR/LAND ROVER
JEEP/CHRYSLER
MERCEDES-BENZ
RENAULT/DACIA/NISSAN
OPEL/VAUXHALL
VAG
VOLVO
OUTRAS
FERRAMENTAS ADICIONAIS



335 LUBRIFICAÇÃO/COMBUSTÍVEL

BOMBAS DE ABASTECIMENTO DIESEL
BOMBAS DE ABASTECIMENTO DE UREIA
BOMBAS DE ENCHIMENTO/EXTRAÇÃO
COLETORES DE ÓLEO
BALDES DE COLEÇÃO DE ÓLEO
PISTOLAS DE SUÇÃO
OUTROS



351 FERRAMENTAS HIDRÁULICAS

MACACOS HIDRÁULICOS DE RODAS
 MACACOS TIPO GARRAFA
 MACACOS DE MANIVELA
 MACACO HIDRÁULICO TELESCÓPICO
 CAVALETES
 OUTROS
 PORTA PALETES MANUAL
 PRENSAS
 GUINDASTES
 MESAS DE ELEVÇÃO
 BASES SE ELEVÇÃO



367 FERRAMENTAS ELÉTRICAS

ARRANCADOR
 MANUTENÇÃO DE BATERIAS
 MEDIÇÃO DE CORRENTE
 INSPEÇÃO VISUAL
 SOLDADORA
 EQUIPAMENTO PARA OFICINA
 CLIMATIZAÇÃO
 TERMÔMETROS
 OUTROS



385 MOBILIDADE DO FUTURO

CABOS PARA CARREGAR DE CARROS ELÉTRICOS
 CARREGADORES DE CARRO ELÉTRICO
 FERRAMENTAS COM ISOLAMENTO



391 ACESSÓRIOS DE OFICINA

ENROLADOR DE MANGUEIRA
 ESCADAS
 CARRINHOS DE MÃO
 PLATAFORMAS
 DIFERENCIAIS



399 ACESSÓRIOS DO VEÍCULO

SINALIZAÇÃO
 KITS DE EMERGÊNCIA
 LÂMPADAS
 KITS DE PRIMEIROS SOCORROS
 SEGURANÇA
 CONJUNTOS DE FOLAS E ABRAÇADEIRAS
 TAPETES
 LIMPADORES DE PARA-BRISAS
 BICICLETA
 OUTROS
 SENSORES DE ESTACIONAMENTO
 TUBOS FLEXÍVEIS



415 ACESSÓRIOS DE PNEUS

CONTRAPESOS
 REPARAÇÃO DE FUROS
 VÁLVULAS DE PNEUS
 REMOÇÃO E INSTALAÇÃO



425 SEGURANÇA E EPI

LUVAS/EPI
DISPENSADORES
MEDIDOR DE OZONO
DELIMITAÇÃO



431 CONSUMÍVEIS

CHAVETAS E ANÉIS DE RETENÇÃO
REBITES
PARAFUSOS, PORCAS, ARRUELAS
ARRUELAS PARA MOTOR E CARTER
OUTROS
JUNTAS E ANÉIS DE VEDAÇÃO
CONECTORES DE MANGUEIRAS
ELÉTRICOS
AGRAFOS E PRESILHAS DE PLÁSTICO



453 PROMOCIONAL

PRODUTOS PROMOCIONAIS
ECRÃS / ACESSÓRIOS
EMBALAGENS
ROUPAS DE TRABALHO



Descubra mais com os nossos códigos QR

Ao longo do catálogo, encontrará códigos QR que lhe permitirão aceder diretamente a desenhos explodidos detalhados e listas de peças sobressalentes dos nossos produtos. Além disso, alguns códigos levá-lo-ão à nossa videoteca online para uma experiência ainda mais completa. Amplie as informações deste catálogo explorando os nossos outros canais de comunicação.



Novos Produtos

Alguns artigos do catálogo estão destacados com uma moldura verde pastel e possuem um ícone ao lado das informações logísticas com o nome "NEW". Isso indica que são produtos novos, ou seja, novidades adicionadas este ano em relação ao catálogo anterior.



JBM é a sua marca de ferramentas profissionais

Empresa líder, especializada na indústria e no setor automotivo

Mais de 30 anos de experiência no setor

Na JBM somos especialistas na distribuição de ferramentas e equipamentos automotivos, oferecendo um atendimento próximo e de qualidade aos nossos mais de 11.000 clientes espalhados por mais de 68 países.

Ampla gama de produtos

Oferecemos uma gama completa de mais de 7.000 itens como caixas de ferramentas, estojos, mobiliário para oficina, todos os tipos de ferramentas manuais, ferramentas de oficina, iluminação, estojos de consumíveis...

Especialistas em distribuição e logística

A JBM dispõe de uma rede logística em constante melhoria, que permite uma distribuição rápida e eficiente não só na Península Ibérica mas também a todos os clientes internacionais.



Eficiência logística

Simplifica o manuseamento e o seguimento das expedições.



Controlo de qualidade

Monitorizamos de perto todos os processos de produção.



Consolidação própria de pedidos

Optimizamos o agrupamento das expedições para garantir a eficiência logística.



Controlo de prazos

Asseguramos o cumprimento rigoroso dos prazos de produção.

Presença geográfica

Sede em Espanha

A nossa sede em Girona, Espanha, é o coração das nossas operações. Com mais de 6.000m² de espaço de armazém, gerimos o desenvolvimento de produtos, a logística e apoiamos a nossa rede global, garantindo entregas rápidas e eficientes.

Sede na China

Na nossa subsidiária Jinhua JBM Tools Co. Ltd. na China, temos um escritório e um armazém de 4.000m². A partir daí, consolidamos as encomendas, controlamos a qualidade na origem e asseguramos os prazos de produção para fornecer um serviço internacional eficiente.

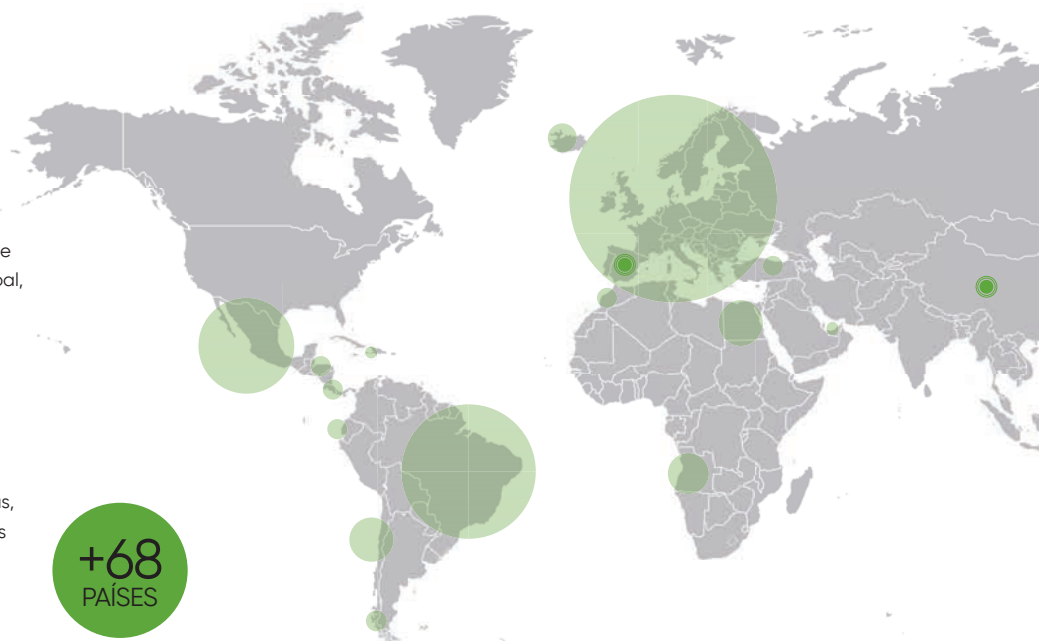

+7.000

Produtos disponíveis

+25.000

Europaletes em estoque

+550

Novos produtos por ano

CONJUNTOS DE FERRAMENTAS

- 8 CONJUNTOS DE FERRAMENTAS
- 18 CONJUNTOS DE CHAVES DE CAIXA
- 23 CAIXAS / MALETAS DE FERRAMENTAS
- 28 CONJUNTOS DE PONTAS
- 32 CONJUNTO DE CATRACAS MINI
- 33 CONJUNTO DE ADAPTADORES
- 33 KIT DE PONTAS
- 33 KIT DE CHAVES DE CAIXA
- 35 FERRAMENTAS COM ISOLAMENTO



54863

499,00€

15.00 - 1 30



NEW

MALA DE FERRAMENTAS COM CHAVE DE IMPACTO SEM ESCOVAS A BATERIA 800NM



REPOSIÇÕES DISPONÍVEIS

		1/2" x4 17, 19, 21, 22mm
		3/8" x10 10, 11, 12, 13, 14, 15, 16, 17, 18, 19mm
		1/2" x7 21, 22, 23, 24, 27, 30, 32mm
		x2 PH2, PH3
		x2 PZ2, PZ3
		x2 SL5.5, SL6.5
		x5 H3, H4, H5, H6, H8
		x10 T5, T6, T7, T8, T9, T10, T15, T20, T25, T30
		x6 H2, H3, H4, H5, H6, H7
		x4 PH1, PH2, PH3, PH4
		x4 PZ1, PZ2, PZ3, PZ4
		x7 SL3, SL4, SL5, SL5.5, SL6, SL6.5, SL7
		3/8" x7 E10, E11, E12, E14, E16, E18, E20
		1/4" 13 4, 4.5, 5, 5.5, 6, 7, 8, 9, 10, 11, 12, 13, 14mm
		1/4" x1 145mm
		3/8" x1 200mm
		1/2" x1 255mm
		x1
		x1
		x4 1/4"-6mm, H3/8"-M1/4", H3/8"-M 3/8", H1/2"-M3/8"

		x12 6, 8, 9, 10, 11, 12, 13, 14, 15, 17, 18, 19mm
		x7 T8, T10, T15, T20, T25, T30, T40
		1/4" x4 8, 9, 10, 12mm
		3/8" x4 13, 14, 15, 17mm
		1/4" x1 Universal
		3/8" x1 Universal
		1/2" x1 Universal
		1/2" x2 16, 21mm
		1/4" x1 50mm
		3/8" x2 125, 250mm
		1/2" x2 75, 150mm
		1/4" x1
		x1 PH3x150
		x1 SL6.5x150
		x1 60013 (4.0AH)
		x1 60066 (20V - 2A)
		x1 60046 (1/2" 800NM)

Organize e proteja as suas ferramentas com os nossos estojos

TRANSPORTE FÁCIL

O design ergonómico e compacto permite um transporte fácil para qualquer lugar.



54854

219,00€

920 - 2 48



NEW

MALA DE FERRAMENTAS DE 232 PEÇAS COM CHAVES HEXAGONAIS ZINCADAS



REPOSIÇÕES DISPONÍVEIS

	x13	4, 4.5, 5, 5.5, 6, 7, 8, 9, 10, 11, 12, 13, 14mm
	x14	E4, E5, E6, E7, E8, E10, E11, E12, E14, E16, E18, E20, E22, E24
	x2	2", 4"
	x1	110mm
	1/4"	x1
	x1	UNIVERSAL
	x1	150mmL
	x10	5, 5.5, 6, 7, 8, 9, 10, 11, 12, 13mm
	x11	15, 16, 17, 19, 20, 21, 22, 24, 27, 30, 32mm
	x2	5", 10"
	1/2"	x1 38L
	x1	UNIVERSAL
	x1	3/8" (F) x 1/2" (M)
	x1	

	x3	PH1, PH2, PH3
	x7	T10, T15, T20, T25, T27, T30, T40
	x3	PZ1, PZ2, PZ3
	x7	T10T, T15T, T20T, T25T, T27T, T30T, T40T
	x3	SL4, SL5.5, SL6
	x6	H2, H3, H4, H5, H5.5, H6
	x1	ADP.
	x10	PH0 (x5), PH1 (x5)
	x10	PH2 (x5), PH3 (x5)
	x10	PZ0 (x2), PZ1 (x2), PZ2 (x3), PZ3 (x3)
	x10	HT3 (x2), HT4 (x2), HT5 (x3), HT6 (x3)
	x10	T8, T9, T10, T15, T20 (x5), T25
	x8	T25 (x3), T27 (x3), T30, T40
	x9	T8T, T9T, T10T, T15T, T20T, T25T, T27T, T30T, T40T
	x3	M5, M6, M8
	x3	4, 6, 8mm
	x3	6, 8, 10
	x3	1, 2, 3

	x6	PH1, PH2, PH3 (x2), PH4(x2)
	x6	PZ1, PZ2, PZ3(x2), PZ4(x2)
	8mm	x3 SL6, SL6.5, SL8
	x6	T25T, T27T, T30T, T40T, T45T, T50T
	x8	T25, T27, T30, T35, T40(x2), T45, T50
	x12	6, 8, 10, 11, 12, 13, 14, 15, 16, 17, 18, 19mm
	x2	80-115, 120-195mm
	x1	60mmL
	x1	1/4"
	x8	1.5, 2, 2.5, 3, 4, 5, 6, 8mm
	x8	T9, T10, T15, T20, T25, T27, T30, T40

Organize e proteja as suas ferramentas com os nossos estojos

RESISTENTE À ÁGUA

Protege as suas ferramentas de condições de trabalho ou de armazenamento extremas.



54250

188,00€

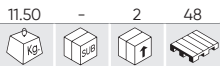

MALA DE FERRAMENTAS DE 216 PEÇAS COM SOQUETES DE 12 PONTAS DE 1/4", 3/8" E 1/2" – ACABAMENTO ZINCADO



REPOSIÇÕES DISPONÍVEIS



	1/2" x14	13, 14, 15, 16, 17, 18, 19, 20, 21, 22, 24, 27, 30, 32mm
	3/8" x10	10, 11, 12, 13, 14, 15, 16, 17, 18, 19mm
	1/4" x13	4, 4.5, 5, 5.5, 6, 7, 8, 9, 10, 11, 12, 13, 14mm
	1/2" x5	16, 17, 18, 19, 22mm
	3/8" x6	10, 11, 12, 13, 14, 15mm
	1/4" x7	4, 5, 6, 7, 8, 9, 10mm
	1/2" x3	E20, E22, E24
	3/8" x6	E10, E11, E12, E14, E16, E18
	1/4" x5	E4, E5, E6, E7, E8
	1/2" x3	1/2", 3/8", 1/4"
	1/2" x2	125, 250mm
	3/8" x1	125mm
	1/4" x2	50, 100mm
	1/2" x1	8mm
	3/8" x1	8mm
	1/4" x1	6mm
	1/4" x1	6mm

	x3	1/2", 3/8", 1/4"
	1/2" x1	adaptador 3/8" H x 1/2" M
	1/2" x2	16, 21mm
	3/8" x1	18mm
	1/2" x12	8, 9, 10, 11, 12, 13, 14, 15, 16, 17, 18, 19mm
	1/2" x7	1.27, 1.5, 2, 2.5, 3, 4, 5mm
	1/4" x1	
	1/4" x1	
	1/4" x1	
	1/2" x1	T70
	1/2" x1	14mm
	x3	PH0, PH1, PH2
	x3	P20, P21, P22
	x4	3, 4, 5, 6mm
	x4	SL4, SL5.5, SL6.5, SL7
	x8	T8, T9, T10, T15, T20, T25, T27, T30
	x8	T8, T9, T10, T15, T20, T25, T27, T30

	8mm x4	7, 8, 10, 12mm
	6mm x6	2, 2.5, 3, 4, 5, 6mm
	8mm x3	SL8, SL10, SL12
	8mm x3	PH2, PH3, PH4
	8mm x3	P22, P23, P24
	8mm x5	T40, T45, T50, T55, T60
	6mm x3	T5, T6, T7
	8mm x5	T40, T45, T50, T55, T60
	6mm x1	T7
	8mm x4	M10, M11, M12, M13
	6mm x5	M5, M6, M7, M8, M9
	8mm x2	M10, M12
	6mm x3	M5, M6, M8
	8mm x1	TS50
	6mm x8	TS10, TS15, TS20, TS25, TS27, TS30, TS40, TS45
	x4	0, 1, 2, 3mm
	x3	6, 8, 10mm
	6mm x4	4, 6, 8, 10mm
	x3	1, 2, 3mm
	x4	1, 2, 3, 4mm

54034

178,00€

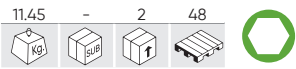

MALA DE FERRAMENTAS DE 216 PEÇAS COM SOQUETES HEXAGONAIS DE 1/4", 3/8" E 1/2" – ACABAMENTO ZINCADO



54045

179,00€

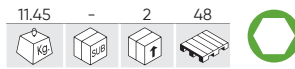

MALA DE FERRAMENTAS DE 216 PEÇAS COM SOQUETES HEXAGONAIS DE 1/4", 3/8" E 1/2" – ACABAMENTO CROMADO



REPOSIÇÕES DISPONÍVEIS



REPOSIÇÕES DISPONÍVEIS



	1/2" x14	13, 14, 15, 16, 17, 18, 19, 20, 21, 22, 24, 27, 30, 32mm
	3/8" x10	10, 11, 12, 13, 14, 15, 16, 17, 18, 19mm
	1/4" x13	4, 4.5, 5, 5.5, 6, 7, 8, 9, 10, 11, 12, 13, 14mm
	1/2" x5	16, 17, 18, 19, 22mm
	3/8" x6	10, 11, 12, 13, 14, 15mm
	1/4" x7	4, 5, 6, 7, 8, 9, 10mm
	1/2" x3	E20, E22, E24
	3/8" x6	E10, E11, E12, E14, E16, E18
	1/4" x5	E4, E5, E6, E7, E8
	12" x3	1/2", 3/8", 1/4"
	1/2" x2	125, 250mm
	3/8" x1	125mm
	1/4" x2	50, 100mm
	1/2" x1	8mm
	3/8" x1	8mm
	1/4" x1	6mm
	1/4" x1	6mm

	x3	1/2", 3/8", 1/4"
	1/2" x1	adaptador 3/8" H x 1/2" M
	1/2" x2	16, 21mm
	3/8" x1	18mm
	1/2" x12	8, 9, 10, 11, 12, 13, 14, 15, 16, 17, 18, 19mm
	1/2" x7	1.27, 1.5, 2, 2.5, 3, 4, 5mm
	1/4" x1	
	1/4" x1	
	1/4" x1	
	1/2" x1	T70
	1/2" x1	14mm
	x3	PH0, PH1, PH2
	x3	PZ0, PZ1, PZ2
	x4	3, 4, 5, 6mm
	x4	SL4, SL5.5, SL6.5, SL7
	x8	T8, T9, T10, T15, T20, T25, T27, T30
	x8	T8, T9, T10, T15, T20, T25, T27, T30

	8mm x4	7, 8, 10, 12mm
	6mm x6	2, 2.5, 3, 4, 5, 6mm
	8mm x3	SL8, SL10, SL12
	8mm x3	PH2, PH3, PH4
	8mm x3	PZ2, PZ3, PZ4
	8mm x5	T40, T45, T50, T55, T60
	6mm x3	T5, T6, T7
	8mm x5	T40, T45, T50, T55, T60
	6mm x1	T7
	8mm x4	M10, M11, M12, M13
	6mm x5	M5, M6, M7, M8, M9
	8mm x2	M10, M12
	6mm x3	M5, M6, M8
	8mm x1	TS50
	6mm x8	TS10, TS15, TS20, TS25, TS27, TS30, TS40, TS45
	x4	0, 1, 2, 3mm
	x3	6, 8, 10mm
	6mm x4	4, 6, 8, 10mm
	x3	1, 2, 3mm
	x4	1, 2, 3, 4mm

54035

149,00€



MALA DE FERRAMENTAS DE 179 PEÇAS COM SOQUETES HEXAGONAIS DE 1/4", 3/8" E 1/2" – ACABAMENTO ZINCADO



54046

150,00€



MALA DE FERRAMENTAS DE 179 PEÇAS COM SOQUETES HEXAGONAIS DE 1/4", 3/8" E 1/2" – ACABAMENTO CROMADO



REPOSIÇÕES DISPONÍVEIS



REPOSIÇÕES DISPONÍVEIS



	1/2" x17	10, 11, 12, 13, 14, 15, 16, 17, 18, 19, 20, 21, 22, 24, 27, 30, 32mm
	3/8" x10	10, 11, 12, 13, 14, 15, 16, 17, 18, 19mm
	1/4" x13	4, 4.5, 5, 5.5, 6, 7, 8, 9, 10, 11, 12, 13, 14mm
	1/2" x5	16, 17, 18, 19, 22mm
	3/8" x6	10, 11, 12, 13, 14, 15mm
	1/4" x7	4, 5, 6, 7, 8, 9, 10mm
	1/2" x2	E20, E24
	3/8" x6	E10, E11, E12, E14, E16, E18
	1/4" x5	E4, E5, E6, E7, E8
		x3 1/2", 3/8", 1/4"
	1/2" x2	125, 250mm
	3/8" x1	125mm
	1/4" x2	50, 100mm
		x3 1/2", 3/8", 1/4"

	1/2" x2	16, 21mm
	3/8" x1	18mm
	1/2" x1	8mm
	3/8" x1	8mm
	1/4" x1	6mm
		x7 1.27, 1.5, 2, 2.5, 3, 4, 5mm
		x1 1/4"
		x1 1/4"
		x3 PH1, PH2, PH3
		x3 PZ1, PZ2, PZ3
	1/4"	x5 2, 3, 4, 5, 6mm
		x3 SL4, SL5.5, SL7
		x8 T8, T9, T10, T15, T20, T25, T27, T30
		x8 T8, T9, T10, T15, T20, T25, T27, T30

		x11	T5, T6, T7, T8, T9, T10, T15, T20, T25, T27, T30
		x9	T7, T10, T15, T20, T25, T27, T30, T40, T45
	6mm	x5	M5, M6, M7, M8, M9
		x3	M5, M6, M8
		x2	PH3, PH4
		x2	PZ3, PZ4
	8mm	x5	7, 8, 10, 12, 14mm
		x3	SL8, SL10, SL12
		x6	T40, T45, T50, T55, T60, T70
		x6	T40, T45, T50, T55, T60, T70

54036

99,00€



MALA DE FERRAMENTAS DE 113 PEÇAS COM SOQUETES DE 12 PONTAS DE 1/4" E 1/2" – ACABAMENTO ZINCADO



54047

100,00€



MALA DE FERRAMENTAS DE 113 PEÇAS COM SOQUETES DE 12 PONTAS DE 1/4" E 1/2" – ACABAMENTO CROMADO



REPOSIÇÕES DISPONÍVEIS



REPOSIÇÕES DISPONÍVEIS



	1/2" x17	10, 11, 12, 13, 14, 15, 16, 17, 18, 19, 20, 21, 22, 24, 27, 30, 32mm
	1/4" x13	4, 4.5, 5, 5.5, 6, 7, 8, 9, 10, 11, 12, 13, 14mm
	1/2" x5	14, 15, 17, 19, 22mm
	1/4" x8	6, 7, 8, 9, 10, 11, 12, 13mm
	1/2" x8	E10, E11, E12, E14, E16, E18, E20, E24
	1/4" x5	E4, E5, E6, E7, E8
	12	x2 1/2", 1/4"
	1/2"	x2 125, 250mm
	1/4"	x2 50, 100mm

	x2	1/2", 1/4"
	1/2"	x1 adaptador 3/8" H x 1/2" M
	1/2"	x1 8mm
	x5	7, 8, 10, 12, 14mm
	x3	SL8, SL10, SL12
	x2	PH3, PH4
	8mm	x2 PZ3, PZ4
	x5	T40, T45, T50, T55, T60
	x5	5, 6, 8, 10, 12mm

	1/2"	x2 16, 21mm
	x3	1.5, 2, 2.5mm
	x1	1/4"
	x1	1/4"
	x2	PH1, PH2
	x2	PZ1, PZ2
	1/4"	x4 3, 4, 5, 6mm
	x3	SL4, SL5.5, SL6.5
	x7	T8, T10, T15, T20, T25, T27, T30

54037

88,00€

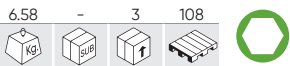

MALA DE FERRAMENTAS DE 108 PEÇAS COM SOQUETES HEXAGONAIS DE 1/4" E 1/2" – ACABAMENTO ZINCADO



54048

89,00€



MALA DE FERRAMENTAS DE 108 PEÇAS COM SOQUETES HEXAGONAIS DE 1/4" E 1/2" – ACABAMENTO CROMADO



REPOSIÇÕES DISPONÍVEIS



REPOSIÇÕES DISPONÍVEIS



	1/2" x17	10, 11, 12, 13, 14, 15, 16, 17, 18, 19, 20, 21, 22, 24, 27, 30, 32mm
	1/4" x13	4, 4.5, 5, 5.5, 6, 7, 8, 9, 10, 11, 12, 13, 14mm
	1/2" x5	14, 15, 17, 19, 22mm
	1/4" x8	6, 7, 8, 9, 10, 11, 12, 13mm
	1/2" x8	E10, E11, E12, E14, E16, E18, E20, E24
	1/4" x5	E4, E5, E6, E7, E8
	12	x2 1/2", 1/4"
	1/2"	x2 125, 250mm
	1/4"	x2 50, 100mm
		x2 1/2", 1/4"
	1/2"	x1 adaptador 3/8" H x 1/2" M

	1/2"	x2 16, 21mm
	1/2"	x1 8mm
		x3 1.5, 2, 2.5mm
		x1 1/4"
		x1 1/4"
		x2 PH3, PH4
		x2 PZ3, PZ4
	8mm	x5 7, 8, 10, 12, 14mm
		x3 SL8, SL10, SL12
		x5 T40, T45, T50, T55, T60

		x2 PH1, PH2
		x2 PZ1, PZ2
	1/4"	x4 3, 4, 5, 6mm
		x3 SL4, SL5.5, SL6.5
		x7 T8, T10, T15, T20, T25, T27, T30

54038

88,00€

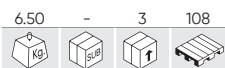

MALA DE FERRAMENTAS DE 94 PEÇAS COM SOQUETES HEXAGONAIS DE 1/4" E 1/2" – ACABAMENTO ZINCADO



54049

89,00€



MALA DE FERRAMENTAS DE 94 PEÇAS COM SOQUETES HEXAGONAIS DE 1/4" E 1/2" – ACABAMENTO CROMADO



REPOSIÇÕES DISPONÍVEIS



REPOSIÇÕES DISPONÍVEIS



	1/2" x18	10, 11, 12, 13, 14, 15, 16, 17, 18, 19, 20, 21, 22, 23, 24, 27, 30, 32mm
	1/4" x13	4, 4.5, 5, 5.5, 6, 7, 8, 9, 10, 11, 12, 13, 14mm
	1/2" x4	14, 15, 17, 19mm
	1/4" x8	6, 7, 8, 9, 10, 11, 12, 13mm
	T2	x2 1/2", 1/4"
	1/2"	x2 125, 250mm
	1/4"	x2 50, 100mm
		x2 1/2", 1/4"
	1/2"	x1 adaptador 3/8" H x 1/2" M

	1/2"	x1 8mm
		x3 1.5, 2, 2.5mm
	1/2"	x2 16, 21mm
		x2 PH3, PH4
		x2 PZ3, PZ4
	8mm	x4 8, 10, 12, 14mm
		x3 SL8, SL10, SL12
		x4 T40, T45, T50, T55
	1/4"	x1 8mm

		x1 1/4"
		x1 1/4"
		x1 1/4"
		x2 PH1, PH2
		x2 PZ1, PZ2
	1/4"	x4 3, 4, 5, 6mm
		x3 SL4, SL5.5, SL7
		x6 T8, T10, T15, T20, T25, T30

53212

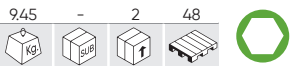

MALA DE FERRAMENTAS DE 302 PEÇAS COM SOQUETES HEXAGONAIS DE 1/2" E 1/4" – ACABAMENTO ZINCADO



REPOSIÇÕES DISPONÍVEIS



	x18	10, 11, 12, 13, 14, 15, 16, 17, 18, 19, 20, 21, 22, 23, 24, 27, 30, 32mm
	x2	125, 250mm
	x2	16, 21mm
	x1	1/2" 8mm
	x1	adaptador 3/8" H x 1/2" M
	x1	UNIVERSAL
	x1	T2
	x13	4, 4.5, 5, 5.5, 6, 7, 8, 9, 10, 11, 12, 13, 14mm
	x2	50, 100mm
	x1	1/4" 6,3mm
	x1	UNIVERSAL
	x1	T2
	x8	T25, T27, T30, T35, T40 (x2), T45, T50
	x2	PH3, PH4
	x2	PZ3, PZ4
	x4	H5.5, H6.5, H7, H8
	x4	5.5, 6.5, 7, 8mm
	x4	5, 6, 8, 10mm

	x9	3, 4, 4.5, 5, 5.5, 6, 6.5, 7, 8mm
	x9	T8, T10, T15, T20, T25, T27, T30, T35, T40
	x9	H1.5, H2, H2.5, H3, H4, H5, H5.5, H6, H8
	x3	5, 6, 8mm
	x4	1, 2, 3, 4
	x3	6, 8, 10
	x3	C1, C2, C3
	x6	6.3x25 mmL 2, 2.5, 3, 4, 5, 6mm
	x4	S0, S1, S2, S3
	x6	5/64, 3/32, 7/64, 1/8, 9/64, 5/32
	x4	4, 6, 8, 10mm
	x10	PH0 (x2), PH1 (x2), PH2 (x4), PH3 (x2)
	x10	PZ0 (x2), PZ1 (x2), PZ2 (x4), Z3 (x2)
	x10	1/16, 5/64, 3/32, 7/64, 1/8, 9/64, 5/32, 3/16, 7/32, 1/4
	x10	T8, T10, T15, T20, T25, T27, T30, T35, T40, T45
	x6	1.5, 2, 2.5, 3, 3.5, 4mm
	x4	PH000, PH00, PH0, PH1
	x2	PZ0, PZ1
	x8	T5, T6, T7, T8, T9, T10, T15, T20

	x1		x1	300g
	x1		x1	
	x10		x1	
	x1		x23	
	x1	3m		x22
	x1		x10	
	x1	8"		x10
	x2	0.4x2.5, 0.5x3.0x50mm		
	x3	PH0x50, PH00x50, PH000x50mm		
	x2	0.8x4x100, 1.2x6.5x125mm		
	x2	PH1x80, PH2x100mm		
	x7	1.27, 1.5, 2, 2.5, 3, 4, 5mm		
	x13	1.5, 2, 2.5, 3, 3.2, 3.5, 4, 4.5, 4.8, 5, 5.5, 6, 6.5mm		

54082

194,00€

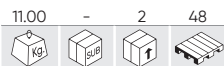

MALA DE FERRAMENTAS DE 132 PEÇAS COM SOQUETES HEXAGONAIS DE 1/2", 1/4" E 3/8" – ACABAMENTO ZINCADO



REPOSIÇÕES DISPONÍVEIS



	1/2" x7	19, 21, 22, 24, 27, 30, 32mm
	3/8" x12	8, 9, 10, 11, 12, 13, 14, 15, 16, 17, 18, 19mm
	1/4" x11	4, 5, 5.5, 6, 7, 8, 9, 10, 11, 12, 13mm
	3/8" x4	13, 14, 15, 17mm
	1/4" x4	8, 10, 12, 13mm
	3/8" x6	E8, E10, E11, E14, E16, E20
	1/2" x1	
	3/8" x1	
	1/4" x1	
	1/2" x2	127, 254mm
	3/8" x2	76, 152mm
	1/4" x1	50mm
	x1	Ø14mm
	x1	

	x1	3/8"(H) - 1/2"(M)
	x1	3/8"(H) - 1/2"(M)
	x1	3/8"(H) - 1/4"(M)
	1/2" x1	
	3/8" x1	
	1/4" x1	
	1/2" x3	17, 19, 21mm
	1/4" x1	6mm
	x1	
	x1	PH2x100
	x1	SL6x100
	x12	8, 9, 10, 11, 12, 13, 14, 15, 16, 17, 18, 19mm
	x1	
	1/2" x1	H17
	x1	

	1/2" x1	21mm
	3/8" x2	16, 18mm
	1/2" x1	T52
	1/2" x1	M16
	x2	5.5, 6.5mm
	x2	PH1, PH3
	3/8" x2	PZ1, PZ3
	x4	4, 5, 6, 8mm
	x6	T20, T30, T40, T45, T50, T55
	x3	4, 5, 6.5mm
	x3	PH1, PH2, PH3
	6mm x3	PZ1, PZ2, PZ3
	x4	3, 4, 5, 6
	x7	T10, T15, T20, T25, T27, T30, T40
	x9	1.5, 2, 2.5, 3, 4, 5, 6, 8, 10mm

53074

84,00€

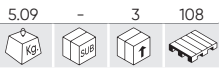

MALA DE FERRAMENTAS DE 74 PEÇAS COM SOQUETES DE 12 PONTAS 1/2" E 1/4" – ACABAMENTO ZINCADO



REPOSIÇÕES DISPONÍVEIS



	1/2"	x18	10, 11, 12, 13, 14, 15, 16, 17, 18, 19, 20, 21, 22, 23, 24, 27, 30, 32mm
	1/4"	x10	4, 5, 5.5, 6, 7, 8, 10, 11, 12, 13mm
	72	x1	1/2"
	72	x1	1/4"
	1/2"	x2	125, 250mm
	1/4"	x1	100mm
	+	x5	PH0, PH1, PH2, PH3, PH4
	*	x5	PZ0, PZ1, PZ2, PZ3, PZ4
	6mm	x6	3, 4, 5, 6, 8, 10mm
	6mm	x5	SL3, SL4, SL5.5, SL6, SL7
	6mm	x8	T8, T10, T15, T20, T25, T27, T30, T40
	6mm	x4	4, 5, 6, 7mm
	1/4"	x1	6mm
	1/4"	x1	1/2"
	1/2"	x1	21mm

54140

38,00€



MALA DE FERRAMENTAS DE 56 PEÇAS COM SOQUETES DE 12 PONTAS 1/4" – ACABAMENTO ZINCADO



REPOSIÇÕES DISPONÍVEIS



	1/4"	x13	4, 4.5, 5, 5.5, 6, 7, 8, 9, 10, 11, 12, 13, 14mm
	72	x1	1/4"
	1/4"	x2	50, 100mm
	1/4"	x1	1/4"
	1/4"	x1	1/4"
	1/4"	x1	1/4"
	1/4"	x1	1/4"
	1/4"	x1	1/4"
	1/4"	x1	1/4"
	1/4"	x4	SL4, SL5, SL6, SL7
	1/4"	x3	M5, M6, M8
	1/4"	x8	T8, T10, T15, T20, T25, T27, T30, T40
	CR-V 25 L	x8	T8, T10, T15, T20, T25, T27, T30, T40
	1/4"	x3	PH0, PH1, PH2
	1/4"	x3	PZ0, PZ1, PZ2
	1/4"	x6	3, 4, 5, 6, 7, 8mm

54108

69,00€



MALA DE FERRAMENTAS DE 22 PEÇAS COM SOQUETES HEXAGONAIS 1/2" – ACABAMENTO ZINCADO



REPOSIÇÕES DISPONÍVEIS



	1/2"	x17	10, 11, 12, 13, 14, 15, 16, 17, 18, 19, 20, 21, 22, 24, 27, 30, 32mm
	72	x1	1/2"
	1/2"	x2	125, 250mm
	1/2"	x1	1/2"
	1/2"	x1	3/8"(H) - 1/2"(M)

54116

69,00€



MALA DE FERRAMENTAS DE 22 PEÇAS COM SOQUETES DE 12 PONTAS 1/2" – ACABAMENTO ZINCADO



REPOSIÇÕES DISPONÍVEIS



	1/2"	x17	10, 11, 12, 13, 14, 15, 16, 17, 18, 19, 20, 21, 22, 24, 27, 30, 32mm
	72	x1	1/2"
	1/2"	x2	125, 250mm
	1/2"	x1	1/2"
	1/2"	x1	3/8"(H) - 1/2"(M)

54106

89,00€

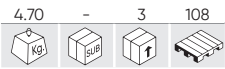

MALA DE FERRAMENTAS EM POLEGADAS ZINCADA COM 37 PEÇAS



REPOSIÇÕES DISPONÍVEIS



		1/2"	x17	5/16", 3/8", 7/16", 1/2", 9/16", 19/32", 5/8", 11/16", 3/4", 13/16", 7/8", 15/16", 1", 1-1/16", 1-1/8", 1-3/16", 1-1/4"
		1/2"	x1	
		1/2"	x1	10" (250mm)
		1/2"	x1	5" (125mm)
		1/2"	x2	13/16", 5/8"
		1/2"	x1	UNIVERSAL
		1/4"	x8	3/16", 7/32", 1/4", 9/32", 5/16", 11/32", 3/8", 7/16"
		1/4"	x1	
		1/4"	x1	3" (75mm)
		1/4"	x1	4,5" (115mm)
		1/4"	x1	6" (150mm)
		1/4"	x1	UNIVERSAL

54258

58,00€



MALA DE FERRAMENTAS DE 77 PEÇAS – ACABAMENTO ZINCADO



	x5	PH0, PH1, PH2, PH2, PH3		x1
	x5	PZ0, PZ1, PZ2, PZ2, PZ3		x1
	x5	SL3, SL4, SL5, SL5.5, SL6mm		x1
	x5	T10, T15, T20, T25, T30		x1
	x4	6x7, 8x9, 10x11, 12x13mm		x1
	x9	1.5, 2, 2.5, 3, 4, 5, 6, 8, 10mm		x1
	x3	PH2x100, PH00x50, PH000x50		x1
	x3	SL6x100, SL2.5x50, SL3.0x50		x10
	x1			x10
	x10			

51818

109,00€

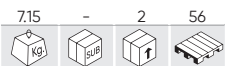

MALA DE FERRAMENTAS DE 72 PEÇAS COM SOQUETES HEXAGONAIS 1/4" E 1/2" – ACABAMENTO ZINCADO

		1/2"	x13	10, 11, 12, 13, 14, 15, 17, 19, 22, 24, 27, 30, 32mm
		1/4"	x10	4, 5, 6, 7, 8, 9, 10, 11, 12, 13mm
		1/4"	x5	5, 6, 7, 8, 9mm
		1/2"	x1	1/2"
		1/4"	x1	1/4"
		1/2"	x1	125mm
		1/4"	x1	75mm
			x2	1/2", 1/4"
		1/2"	x2	16, 21mm
		1/4"	x1	6mm
			x8	10, 11, 12, 13, 14, 15, 17, 19mm
			x3	1.5, 2, 2.5mm
			x1	1/4"
			x2	PH2x100, PH1x40mm
			x3	8x200, 6x100, 6x40mm
			x1	



REPOSIÇÕES DISPONÍVEIS

	x1	300gr
	x1	
	x1	
	x4	SL3, SL4, SL5, SL6
	x3	PH1, PH2, PH3
	x7	T10, T15, T20, T25, T27, T30, T40

54277

58,00€

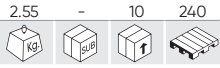

ESTOJO DE FERRAMENTAS 3/8" DE 59 PEÇAS COM CHAVES HEXAGONAIS ZINCADAS



REPOSIÇÕES DISPONÍVEIS



	3/8" x17	6, 7, 8, 9, 10, 11, 12, 13, 14, 15, 16, 17, 18, 19, 20, 21, 22mm
	3/8" x1	72
	3/8" x2	75, 150mm
	3/8" x1	8mm
	3/8" x1	8mm
	3/8" x1	
	1/4" x1	
	1/4" x2	PH1, PH2
	1/4" x2	PZ1, PZ2
	1/4" x4	3, 4, 5, 6mm
	1/4" x3	SL4, SL5.5, SL6.5
	1/4" x7	T8, T10, T15, T20, T25, T27, T30
	8mm x2	PH3, PH4
	8mm x2	PZ3, PZ4
	8mm x5	7, 8, 10, 12, 14mm
	8mm x3	SL8, SL10, SL12
	8mm x5	T40, T45, T50, T55, T60

54168

49,00€



ESTOJO DE FERRAMENTAS DE 59 PEÇAS COM SOQUETES DE 12 PONTOS 3/8" – ACABAMENTO ZINCADO



REPOSIÇÕES DISPONÍVEIS



	3/8" x17	6, 7, 8, 9, 10, 11, 12, 13, 14, 15, 16, 17, 18, 19, 20, 21, 22mm
	3/8" x1	72
	3/8" x2	75, 150mm
	3/8" x1	8mm
	3/8" x1	8mm
	3/8" x1	
	1/4" x1	
	1/4" x2	PH1, PH2
	1/4" x2	PZ1, PZ2
	1/4" x4	3, 4, 5, 6mm
	1/4" x3	SL4, SL5.5, SL6.5
	1/4" x7	T8, T10, T15, T20, T25, T27, T30
	8mm x2	PH3, PH4
	8mm x2	PZ3, PZ4
	8mm x5	7, 8, 10, 12, 14mm
	8mm x3	SL8, SL10, SL12
	8mm x5	T40, T45, T50, T55, T60

54109

34,00€

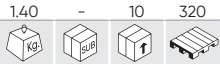

ESTOJO DE FERRAMENTAS DE 46 PEÇAS COM SOQUETES HEXAGONAIS DE 1/4" – ACABAMENTO ZINCADO



REPOSIÇÕES DISPONÍVEIS



	1/4" x13	4, 4.5, 5, 5.5, 6, 7, 8, 9, 10, 11, 12, 13, 14mm
	1/4" x1	
	1/4" x1	72
	1/4" x1	
	1/4" x2	50, 100mm
	1/4" x1	
	1/4" x1	UNIVERSAL
	1/4" x4	1.27, 1.5, 2.0, 2.5mm
	1/4" x3	SL4, SL5.5, SL7
	1/4" x3	PH1, PH2, PH3
	1/4" x3	PZ1, PZ2, PZ3
	1/4" x6	H3, H4, H5, H6, H7, H8
	1/4" x6	T10, T15, T20, T25, T30, T40

54105

33,00€



ESTOJO DE FERRAMENTAS DE 56 PEÇAS COM SOQUETES HEXAGONAIS DE 1/4" – ACABAMENTO ZINCADO



REPOSIÇÕES DISPONÍVEIS



	1/4" x13	4, 4.5, 5, 5.5, 6, 7, 8, 9, 10, 11, 12, 13, 14mm
	72	1/4" x1
	1/4" x2	50, 100mm
	1/4" x1	
	1/4" x1	
	1/4" x1	
	1/4" x1	
	1/4" x1	
	1/4" x1	
	1/4" x1	
	6mm x4	SL4, SL5, SL6, SL7
	6mm x3	M5, M6, M8
	6mm x8	T8, T10, T15, T20, T25, T27, T30, T40
	6mm x8	T8, T10, T15, T20, T25, T27, T30, T40
	6mm x3	PH0, PH1, PH2
	6mm x3	PZ0, PZ1, PZ2
	6mm x6	3, 4, 5, 6, 7, 8mm

54090

56,00€

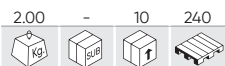

ESTOJO DE FERRAMENTAS GO-THROUGH DE 14 PEÇAS COM SOQUETES DE 1/2" – ACABAMENTO ZINCADO

		x11	13, 14, 15, 16, 17, 18, 19, 21, 22, 24, 27mm
		x1	75mm
		x1	1/2"
		x1	255mm



REPOSIÇÕES DISPONÍVEIS



VÍDEO TUTORIAL

ESTOJOS CONCEBIDOS PARA FACILITAR OS TRABALHOS DE APERTO E DESAPERTO

A característica do sistema "GO-THROUGH" é o seu design de passagem, o que significa que permite trabalhar com parafusos ou cavilhas salientes - algo que as ferramentas tradicionais não conseguem fazer devido à limitação de profundidade da chave.



53108

92,00€



MALA DE FERRAMENTAS DE 60 PEÇAS COM SOQUETES SPLINE 1/2" E 1/4" – ACABAMENTO CROMADO



REPOSIÇÕES DISPONÍVEIS

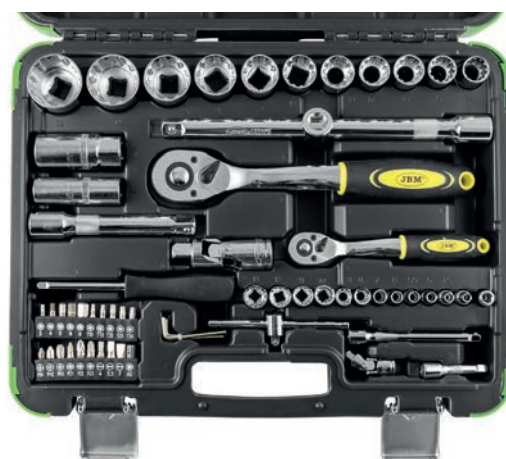

		1/2"	x11	14, 15, 16, 17, 18, 19, 22, 24, 27, 30, 32mm
		1/4"	x12	4, 4.5, 5, 5.5, 6, 7, 8, 9, 10, 11, 12, 13mm
			x2	1/2", 1/4"
		1/2"	x2	5", 10"
		1/4"	x2	2", 4"
			x2	1/2", 1/4"

		1/2"	x2	16, 21mm
			x1	25mm
			x3	1.5, 2, 2.5mm
			x1	1/4"
			x1	1/4"
			x1	AD

			x3	PH1, PH2, PH3
			x3	PZ1, PZ2, PZ3
		25mm	x5	3, 4, 5, 6, 8mm
			x3	SL4, SL5.5, SL7
			x5	T10, T15, T20, T25, T30
			x1	

53953

29,00€

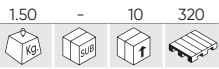

ESTOJO DE FERRAMENTAS DE 130 PEÇAS COM SOQUETES E PONTAS DE 1/4" – ACABAMENTO ZINCADO



REPOSIÇÕES DISPONÍVEIS

		1/4"	x13	4, 4.5, 5, 5.5, 6, 7, 8, 9, 10, 11, 12, 13, 14mm
		1/4"	x1	6mm
		1/4"	x1	50mm
		1/4"	x1	
		1/4"	x7	1.27, 1.5, 2, 2.5, 3, 4, 5mm

		25mm	x10	1/16, 5/64, 3/32, 7/64, 1/8, 9/64, 5/32, 3/16, 7/32, 1/4
		25mm	x9	1.5, 2, 2.5, 3, 4, 5, 5.5, 6, 8mm
		25mm	x6	5/64, 3/32, 7/64, 1/8, 9/64, 5/32
		25mm	x6	2, 2.5, 3, 4, 5, 6mm
		25mm	x9	3, 4, 4.5, 5, 5.5, 6, 6.5, 7, 8mm
		50mm	x2	4, 6mm
		25mm	x10	PH0(x2), PH1(x2), PH2(x4), PH3(x2)
		50mm	x2	PH1, PH2
		25mm	x10	PZ0(x2), PZ1(x2), PZ2(x4), PZ3(x2)
		25mm	x10	T8, T10, T15, T20, T25, T27, T30, T35, T40, T45
		25mm	x9	T8, T10, T15, T20, T25, T27, T30, T35, T40
		25mm	x3	M5, M6, M8
		25mm	x3	6, 8, 10mm
		25mm	x3	C1, C2, C3
		25mm	x4	1, 2, 3, 4mm
		25mm	x4	4, 6, 8, 10mm
		25mm	x4	0, 1, 2, 3mm

53727

198,00€

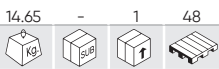

MALA DE FERRAMENTAS DE 21 PEÇAS COM SOQUETES HEXAGONAIS 3/4" – ACABAMENTO ZINCADO



REPOSIÇÕES DISPONÍVEIS

			x16	19, 21, 22, 23, 24, 26, 27, 29, 30, 32, 35, 36, 38, 41, 46, 50mm
		3/4"	x1	495mm
		3/4"	x3	100, 200, 400mm
			x1	445mm

53728

198,00€

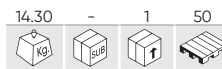

MALA DE FERRAMENTAS DE 21 PEÇAS COM SOQUETES DE 12 PONTOS 3/4" – ACABAMENTO ZINCADO



REPOSIÇÕES DISPONÍVEIS

			x16	19, 21, 22, 23, 24, 26, 27, 29, 30, 32, 35, 36, 38, 41, 46, 50mm
		3/4"	x1	495mm
		3/4"	x3	100, 200, 400mm
			x1	445mm

51616

378,00€

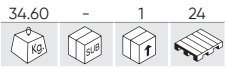

ESTOJO METÁLICO DE 21 SOQUETES HEXAGONAIS 1" – ACABAMENTO ZINCADO



REPOSIÇÕES DISPONÍVEIS



51855

378,00€

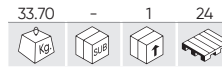

ESTOJO METÁLICO DE 21 SOQUETES DE 12 PONTOS 1" – ACABAMENTO ZINCADO



REPOSIÇÕES DISPONÍVEIS



	1"	x17	36, 38, 41, 46, 50, 54, 55, 58, 60, 63, 65, 67, 70, 71, 75, 77, 80mm
	1"	x1	650mm
	1"	x2	205, 410mm
	1"	x1	

53565

258,00€

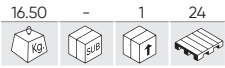

CAIXA METÁLICA DE FERRAMENTAS DE 63 PEÇAS – ACABAMENTO ZINCADO



REPOSIÇÕES DISPONÍVEIS



	1/2"	x18	10, 11, 12, 13, 14, 15, 16, 17, 18, 19, 20, 21, 22, 23, 24, 27, 30, 32mm		x9	1.5, 2, 2.5, 3, 4, 5, 6, 8, 10mm
	1/2"	x1	1/2"		x3	PH1x100, PH2x150, H3x200mm
	1/2"	x1	1/2"		x3	SL5x100, SL6x150, SL8x200mm
	1/2"	x3	76, 127, 254mm		x1	250mm
	1/2"	x1	255mm		x1	200mm
	1/2"	x1	21mm		x1	180mm
		x1	457mm		x1	180mm
		x18	6, 7, 8, 9, 10, 11, 12, 13, 14, 15, 16, 17, 18, 19, 20, 21, 22, 24mm			

54261

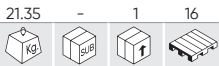

CAIXA METÁLICA DE FERRAMENTAS DE 143 PEÇAS – ACABAMENTO ZINCADO



REPOSIÇÕES DISPONÍVEIS



	x13	4, 4.5, 5, 5.5, 6, 7, 8, 9, 10, 11, 12, 13, 14mm
	x6	8, 10, 11, 12, 13, 14mm
	x7	E4, E5, E6, E7, E8, E10, E11
	x2	2", 4"
	x1	110mmL
	1/4"	x1
	x1	150mmL
	x3	PH1, PH2, PH3
	x3	SL4, SL5.5, SL6.5
	x6	TT10, TT15, TT20, TT25, TT30, TT40
	x6	H3, H4, H5, H6, H7, H8
	x1	
	x1	250mm

	x20	8, 9, 10, 11, 12, 13, 14, 15, 16, 17, 18, 19, 20, 21, 22, 23, 24, 27, 30, 32mm
	x2	5", 10"
	1/2"	x2 16, 21mm
	x1	UNIVERSAL
	x1	3/8"(F) - 1/2"(M)
	1/2" 1/4"	x2 72
	x12	6, 7, 8, 9, 10, 11, 12, 13, 14, 17, 19, 22mm
	x8	6×7, 8×9, 10×11, 12×13, 14×15, 16×17, 18×19, 20×22mm
	x1	7" - 180mm
	x1	8" - 200mm
	x4	SL5×75, SL6×100, SL8×150, SL10×200mmL
	x3	PH1×80, PH2×100, PH3×150mmL

	x4	PH1, PH2(×2), PH3
	x4	PZ1, PZ2(×2), PZ3
	x4	SL3, SL4, SL5, SL6
	x4	H3, H4, H5, H6
	x7	T10, T15, T20, T25, T27, T30, T40
	x7	TT10, TT15, TT20, TT25, TT27, TT30, TT40
	x1	1/4"
	x1	6.35mm×60mmL
	x1	1/4" - 6.35mm
	x1	7" - 180mm
	x1	10" - 250mm



53159

289,00€

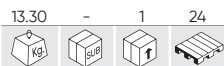

MALA DE ALUMÍNIO DE FERRAMENTAS DE 159 PEÇAS COM SOQUETES DE 1/4" E 1/2" – ACABAMENTO ZINCADO



REPOSIÇÕES DISPONÍVEIS



	1/2" x14	14, 15, 16, 17, 18, 19, 20, 21, 22, 23, 24, 27, 30, 32mm
	1/4" x10	4, 5, 6, 7, 8, 9, 10, 11, 12, 13mm
	x2	1/4", 1/2"
	1/2" x2	50, 100mm
	1/4" x2	125, 250mm
	1/4" x1	150mm
	x2	1/4", 1/2"
	1/2" x1	
	x2	1/4", 1/2"
	1/4" x1	250mm
	1/4" x1	110mm
	1/2" x2	16, 21mm
	x9	8, 10, 11, 12, 13, 15, 17, 19, 22mm
	x9	1.5, 2, 2.5, 3, 4, 5, 6, 8, 10mm
	x1	100-250V
	x1	
	x2	PH1x80, PH2x10mm
	x4	SL3x75, SL4x100, SL6.5x125, SL8x150mm
	x1	PH00x50mm
	x1	SL2.5x50mm
	x1	250mm
	x1	160mm
	x1	180mm
	x1	160mm
	x1	200mm
	x1	180mm
	x1	220mm
	x1	160mm
	x5	
	x1	18mm
	x10	
	x1	300gr
	x40	6.35mm
	x1	3m
	x15	8mm
	x1	200mm
	x1	1/4"



53928



MALA DE ALUMÍNIO DE FERRAMENTAS DE 135 PEÇAS COM SOQUETES DE 1/4" E 1/2" – ACABAMENTO ZINCADO



REPOSIÇÕES DISPONÍVEIS



	x10	10, 11, 12, 13, 14, 15, 17, 19, 22, 24mm		x1	180mm
	x2	16, 21mm		x1	200mm
	x1	UNIVERSAL		x1	160mm
	x2	125, 250mm		x1	200mm
	x1	3/8", 1/2"		x1	18mm
	x1			x1	5m
	x9	4, 5, 6, 7, 8, 9, 10, 11, 12mm		x1	300g
	x1	UNIVERSAL		x1	6mm
	x1			x1	6mL
	x2	50, 100mm		x1	150mm
	x1			x1	
	x1	6mm		x1	
	x9	8, 10, 11, 12, 13, 14, 17, 19, 22mm		x1	
	x4	PH1, PH2, PH2, PH3		x1	
	x4	PZ1, PZ2, PZ2, PZ3		x1	
	x4	SL3, SL4, SL5, SL6		x1	
	x4	H3, H4, H5, H6		x1	
	x7	T10, T15, T20, T25, T27, T30, T40		x1	
	x7	TT10, TT15, TT20, TT25, TT27, TT30, TT40		x1	
	x3	SL1.5, SL2, SL3		x3	
	x4	PH000, PH00, PH0, PH1		x5	
	x8	T4, T5, T6, T7, T8, T10, T15, T20			
	x4	TS0.8, TS1.2, TS1.5, TS2.0			
	x1	H2.0			
	x9	1.5, 2, 2.5, 3, 4, 5, 6, 8, 10mm			
	x2	PH1x80, PH2x100mm			
	x4	SL3.0x75, SL4.0x100, SL6.5x125, SL8x150mm			
	x1	250mm			
	x1	180mm			

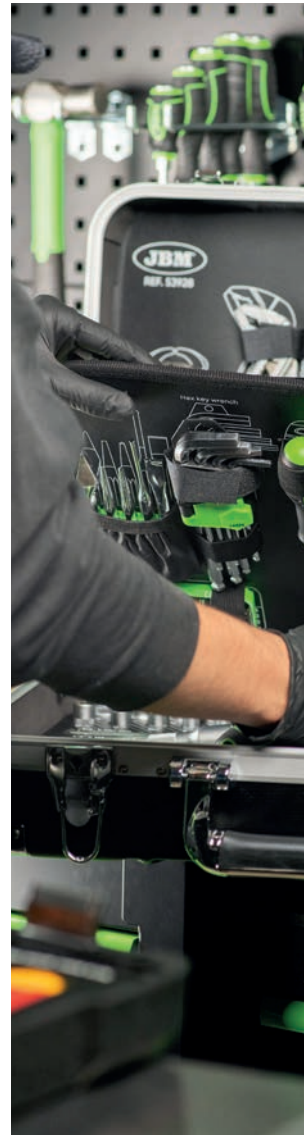
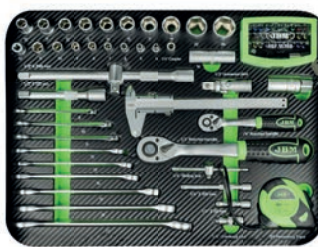

53444

198,00€

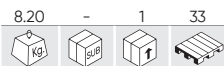

MALA DE ALUMÍNIO DE FERRAMENTAS DE 109 PEÇAS COM SOQUETES DE 1/4" E 1/2" – ACABAMENTO ZINCADO



REPOSIÇÕES DISPONÍVEIS



	x9	10, 11, 12, 13, 14, 15, 17, 18, 19mm
	x2	75, 150mm
	1/2"	x1 16mm
	x1	
	x1	
	x8	4, 4.5, 5, 5.5, 6, 7, 8, 9mm
	1/4"	x1 150mmL
	x1	6mm
	x2	PH1x80, PH2x100mm
	x4	SL3x75, SL4x100, SL6.5x125, SL8x150mm
	x1	PH00x50mm
	x1	SL2.5x50mm
	x1	
	x8	6x7, 8x9, 10x11, 12x13, 14x15, 16x17, 18x19, 20x22mm
	x9	1.5, 2, 2.5, 3, 4, 5, 6, 8, 10mm
	x1	
	x6	
	x1	200mm
	x1	18mm
	x10	
	x1	220mm
	x1	180mm
	x1	160mm
	x1	250mm
	x1	160mm
	x32	
	x1	
	x1	300g
	x1	3m



52603

79,00€

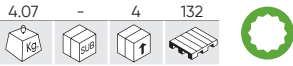

MALETA DE FERRAMENTAS DE 26 PEÇAS COM PONTAS DE 12 CANTOS 1/2"



REPOSIÇÕES DISPONÍVEIS

	x8 (55mmL)	M5, M6, M8, M9, M10, M12, M14, M16
	x7 (100mmL)	M5, M6, M8, M9, M10, M12, M14
	x7 (140mmL)	M5, M6, M8, M9, M10, M12, M14
	x4 (200mmL)	M8, M10, M12, M14

52604

79,00€



MALETA DE FERRAMENTAS DE 30 PEÇAS COM PONTAS HEXAGONAIS 1/2"



REPOSIÇÕES DISPONÍVEIS

	x9 (55mmL)	5, 6, 7, 8, 10, 12, 14, 17, 19mm
	x8 (100mmL)	5, 6, 7, 8, 10, 11, 12, 13mm
	x7 (140mmL)	5, 6, 7, 8, 10, 12, 14mm
	x6 (200mmL)	5, 6, 7, 8, 10, 12mm

52605

79,00€

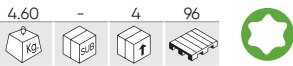

MALETA DE FERRAMENTAS DE 32 PEÇAS COM PONTAS TORX



REPOSIÇÕES DISPONÍVEIS

	x10 (55mmL)	T20, T25, T27, T30, T40, T45, T50, T55, T60, T70
	x10 (100mmL)	T20, T25, T27, T30, T40, T45, T50, T55, T60, T70
	x6 (140mmL)	T40, T45, T50, T55, T60, T70
	x6 (200mmL)	T40, T45, T50, T55, T60, T70

52606

88,00€



MALETA DE FERRAMENTAS DE 32 PEÇAS COM PONTAS RIBE 1/2"



REPOSIÇÕES DISPONÍVEIS

	x9 (55mmL)	M5, M6, M7, M8, M9, M10, M12, M13, M14
	x9 (100mmL)	M5, M6, M7, M8, M9, M10, M12, M13, M14
	x7 (140mmL)	M7, M8, M9, M10, M12, M13, M14
	x7 (200mmL)	M7, M8, M9, M10, M12, M13, M14

54266

39,50€

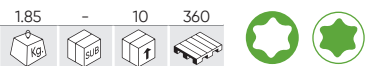

CONJUNTO DE 19 SOQUETES E PONTAS TORX 1/2"



REPOSIÇÕES DISPONÍVEIS



- x9 E10, E11, E12, E14, E16, E18, E20, E22, E24
- x10 T20, T25, T27, T30, T40, T45, T50, T55, T60, T70

54164

34,00€

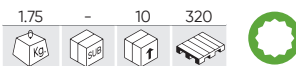

CONJUNTO DE 12 PONTAS DE 12 CANTOS 1/2"



REPOSIÇÕES DISPONÍVEIS



- x6 55mmL M4, M5, M6, M7, M8, M9
- x6 70mmL M10, M12, M14, M16, M18, M20

54154

37,50€



CONJUNTO DE 12 PONTAS TORX 1/2"



REPOSIÇÕES DISPONÍVEIS



- x6 55mmL T20, T25, T30, T40, T45, T50
- x6 70mmL T55, 60, T70, T80, T90, T100

51260

37,00€

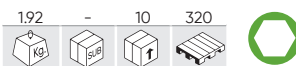

CONJUNTO DE 12 PONTAS HEXAGONAIS 1/2"



REPOSIÇÕES DISPONÍVEIS



- x6 55mmL H5, H6, H7, H8, H10, H12
- x1 65mmL H14
- x5 70mmL H16, H17, H18, H19, H22

54539

129,00€



MALETA DE FERRAMENTAS DE 77 PEÇAS COM SOQUETES E PONTAS TORX/TORX PLUS

	1/4"	x5	E4, E5, E6, E7, E8
	3/8"	x4	E10, E12, E14, E16
	1/2"	x4	E18, E20, E22, E24
	1/4"	x5	EPL4, EPL5, EPL6, EPL7, EPL8
	3/8"	x4	EPL10, EPL12, EPL14, EPL16
	1/2"	x4	EPL18, EPL20, EPL22, EPL24
	1/4"	x8	T6, T8, T10, T15, T20, T25, T27, T30
	3/8"	x5	T40, T45, T47, T50, T55
	1/2"	x2	T60, T70
	1/4"	x7	TB8, TB10, TB15, TB20, TB25, TB27, TB30
	3/8"	x4	TB40, TB45, T50, T55
	1/2"	x1	TB60
	1/4"	x7	IP8, IP10, IP15, IP20, IP25, IP27, IP30
	3/8"	x3	IP40, IP45, IP50
	1/2"	x2	IP55, IP60
	1/4"	x7	IPR8, IPR10, IPR15, IPR20, IPR25, IPR27, IPR30
	3/8"	x3	IPR40, IPR45, IPR50
	1/2"	x2	IPR55, IPR60



REPOSIÇÕES DISPONÍVEIS

54141

44,00€

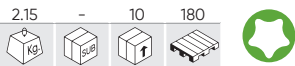

CONJUNTO DE 28 SOQUETES TORX CURTOS E LONGOS 1/2", 1/4" E 3/8" – ACABAMENTO ZINCADO

	1/4"	x5 (25mm)	E4, E5, E6, E7, E8
	3/8"	x5 (28mm)	E10, E11, E12, E14, E16
	1/2"	x4 (38mm)	E18, E20, E22, E24
	1/4"	x5 (50mm)	E4, E5, E6, E7, E8
	3/8"	x5 (63mm)	E10, E11, E12, E14, E16
	1/2"	x4 (76mm)	E18, E20, E22, E24



REPOSIÇÕES DISPONÍVEIS

53915

69,00€

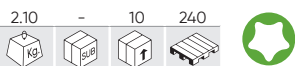

CONJUNTO DE 6 SOQUETES TORX TIPO E EXTRA LONGOS 1/2" – ACABAMENTO ZINCADO

	1/2"	x6	140mm E10, E12, E14, E16, E18, E20
--	------	----	------------------------------------

E12 Soquete para cabeça do bloco de cilindros BMW:
 - Motor M42, 1,8 L, 4 cilindros, 16 V, modelo 318 (1989)
 - Motor M50, 2.0L, 2.5L, 6 cilindros, 24V, modelos 520i, 525i (1991)



50983

48,00€

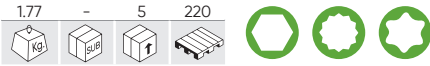

MALETA DE FERRAMENTAS DE 42 PEÇAS COM PONTAS HEXAGONAIS, DE 12 CANTOS E TORX 1/2" E 3/8"



REPOSIÇÕES DISPONÍVEIS



	3/8"	x1	10mm
	1/2"	x1	10mm
	30mm	x7	4, 5, 6, 7, 8, 10, 12mm
	75mm	x7	4, 5, 6, 7, 8, 10, 12mm
	30mm	x8	T20, T25, T30, T40, T45, T50, T55, T60
	75mm	x8	T20, T25, T30, T40, T45, T50, T55, T60
	30mm	x5	M5, M6, M8, M10, M12
	75mm	x5	M5, M6, M8, M10, M12

50985

59,00€

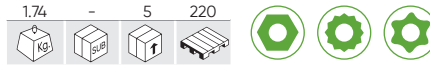

MALETA DE FERRAMENTAS DE 42 PEÇAS COM PONTAS HEXAGONAIS, DE 12 CANTOS E TORX INVIOVÁVEIS 1/2" E 3/8"



REPOSIÇÕES DISPONÍVEIS

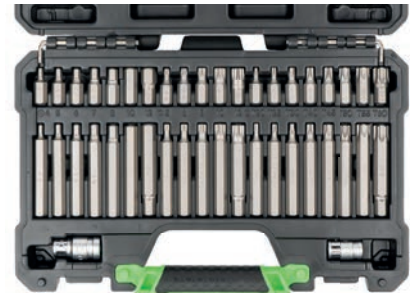

	3/8"	x1	10mm
	1/2"	x1	10mm
	30mm	x7	4, 5, 6, 7, 8, 10, 12mm
	75mm	x7	4, 5, 6, 7, 8, 10, 12mm
	30mm	x8	T20, T25, T30, T40, T45, T50, T55, T60
	75mm	x8	T20, T25, T30, T40, T45, T50, T55, T60
	30mm	x5	M5, M6, M8, M10, M12
	75mm	x5	M5, M6, M8, M10, M12

52550

98,00€



MALETA DE FERRAMENTAS DE 75 PEÇAS COM PONTAS HEXAGONAIS, XZN, RIBE, TÔRX E TORX INVIOVÁVEIS 1/2" E 3"



REPOSIÇÕES DISPONÍVEIS



	3/8"	x1	10mm
	1/2"	x2	10mm
	30mm	x7	4, 5, 6, 7, 8, 10, 12mm
	75mm	x7	4, 5, 6, 7, 8, 10, 12mm
	30mm	x8	T20, T25, T30, T40, T45, T50, T55, T60
	75mm	x8	T20, T25, T30, T40, T45, T50, T55, T60
	30mm	x5	M5, M6, M8, M10, M12
	75mm	x5	M5, M6, M8, M10, M12
	30mm	x8	R5, R6, R7, R8, R9, R10, R12, R14
	75mm	x8	R5, R6, R7, R8, R9, R10, R12, R14
	30mm	x8	TT20, TT25, TT30, TT40, TT45, TT50, TT55, TT60
	75mm	x8	TT20, TT25, TT30, TT40, TT45, TT50, TT55, TT60

52753

107,00€

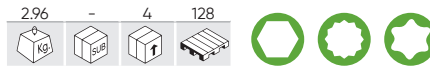

MALETA DE FERRAMENTAS DE 55 PEÇAS COM PONTAS HEXAGONAIS, DE 12 CANTOS E TORX E ADAPTADORES 1/2" E 3/8"



REPOSIÇÕES DISPONÍVEIS



	3/8"	x1	10mm
	1/2"	x2	10, 14mm
	30mm	x9	4, 5, 6, 7, 8, 10, 12, 14, 16mm - ISO 2136
	75mm	x9	4, 5, 6, 7, 8, 10, 12, 14, 16mm - ISO 2136
	30mm	x10	T20, T25, T30, T40, T45, T50, T55, T60, T70, T80 - DIN 2325
	75mm	x10	T20, T25, T30, T40, T45, T50, T55, T60, T70, T80 - DIN 2325
	30mm	x7	M5, M6, M8, M10, M12, M14, M16 - DIN 2325
	75mm	x7	M5, M6, M8, M10, M12, M14, M16 - DIN 2325

HEAVY DUTY

49,50€

53574



MALETA DE FERRAMENTAS DE 208 PEÇAS COM PONTAS 1/4" E ADAPTADOR DE CHAVE DE FENDA

	25mmL	x12	1,5, 2, 2,5, 3, 3,5, 4, 4,5, 5, 5,5, 6, 7, 8mm
		x10	1/16, 5/64, 3/32, 7/64, 1/8, 9/64, 5/32, 3/16, 7/32, 1/4
	50mmL	x5	2,5, 3, 4, 5, 6mm
		x5	2,5, 3, 4, 5, 6mm
	25mmL	x18	PH00, PH0, PH1(x5), PH2(x5), PH3(x5), PH4
		x3	PH1, PH2, PH3
	50mmL	x3	PH1, PH2, PH3
		x3	PH1, PH2, PH3
	25mmL	x17	PZ00, PZ0, PZ1(x5), PZ2(x5), PZ3(x4), PZ4
		x3	PZ1, PZ2, PZ3
	75mmL	x3	PZ1, PZ2, PZ3
		x3	PZ1, PZ2, PZ3
	25mmL	x14	T5, T6, T7, T8, T9, T10, T15, T20, T25, T27, T30, T35, T40, T45
		x7	T10, T15, T20, T25, T27, T30, T40
	50mmL	x7	T10, T15, T20, T25, T27, T30, T40
		x7	T10, T15, T20, T25, T27, T30, T40
	25mmL	x10	4, 5, 6, 7, 8, 9, 10, 11, 12, 13
		x10	5/32, 3/16, 7/32, 1/4, 9/32, 5/16, 11/32, 3/8, 7/16, 1/2
	25mmL	x1	
		x1	
	25mmL	x3	6, 8, 10mm
		x3	6, 8, 10mm
	50mmL	x3	6, 8, 10mm
		x3	6, 8, 10mm
	25mmL	x4	4, 6, 8, 10mm
		x4	4, 6, 8, 10mm



	25mmL	x4	1, 2, 3, 4mm
		x4	1, 2, 3, 4mm
	50mmL	x4	1, 2, 3, 4mm
		x4	1, 2, 3, 4mm
	25mmL	x6	2, 2,5, 3, 4, 5, 6mm
		x6	5/64, 3/32, 7/64, 1/8, 9/64, 5/32
	25mmL	x13	T5, 6, 7, 8, 9, 10, 15, 20, 25, 27, 30, 40, 45
		x3	1, 2, 3mm
	25mmL	x4	0, 1, 2, 3mm
		x3	M5, M6, M8
	25mmL	x9	TS10, TS15, TS20, TS25, TS27, TS30, TS40, TS45, TS50
		x12	SL2, SL2.5, SL3, SL3.5, SL4, SL4.5, SL5, SL5.5, SL6, SL6.5, SL7, SL8
	6mm	x1	1/4"
		x1	

52620

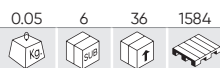

PORTA PONTAS ANGULAR 105° 1/4"

Peças	1
Ângulo	105°
Acabado	Cromo Vanídeo/Chromium vanadium
Peso	0,050Kg



8,80€

53156

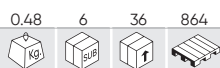

MINI ESTOJO DE 37 PONTAS E SOQUETES COM CATRACA 1/4"

	1/4"	x11	4, 4,5, 5, 6, 7, 8, 9, 10, 11, 12, 13mm
		x1	
	1/4"	x2	PH3, PH4
		x2	PZ3, PZ4
	6mm	x5	4, 5, 6, 7, 8mm
		x3	SL6, SL8, SL10
	6mm	x8	T8, T9, T10, T15, T20, T25, T30, T40
		x4	M5, M6, M9, M10
	1/4"	x1	
		x1	1/4"



REPOSIÇÕES DISPONÍVEIS

26,20€

51333

18,00€

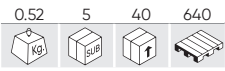

CONJUNTO DE 6 ADAPTADORES 1/4", 3/8", 1/2" E 3/4"



REPOSIÇÕES DISPONÍVEIS



ADAPTADORES CRV

x6 1/4H-3/8M, 1/4M-3/8H, 1/2H-3/4M, 3/8H-1/2M, 1/2H-3/8M, 3/4H-1/2M

53743

39,70€

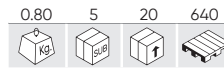

CONJUNTO DE 6 ADAPTADORES DE IMPACTO



REPOSIÇÕES DISPONÍVEIS



ADAPTADORES CRMO

x6 1/4H-3/8M, 3/8H-1/4M, 3/8H-1/2M, 1/2H-3/8M, 1/2H-3/4M, 3/4H-1/2M

54586

5,00€

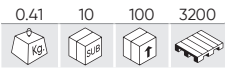

CONJUNTO DE 3 ADAPTADORES DE CHAVES DE CAIXA COM PONTA HEXAGONAL

x1 1/2" 73mm
x1 3/8" 67mm
x1 1/4" 65mm



KIT DE PONTAS

REF.												€
52714	0.65	4	24	576	CrV	10 PCS		1/2"	10, 11, 12, 13, 14, 15, 16, 17, 18, 19mm			17,00€
52715	0.35	6	36	1152	CrV	13 PCS		1/4"	4, 4.5, 5, 5.5, 6, 7, 8, 9, 10, 11, 12, 13, 14mm			11,00€
52716	0.61	4	24	576	CrV	10 PCS		1/2"	10, 11, 12, 13, 14, 15, 16, 17, 18, 19mm			17,00€
52717	0.27	6	36	1152	CrV	13 PCS		1/4"	4, 4.5, 5, 5.5, 6, 7, 8, 9, 10, 11, 12, 13, 14mm			11,00€

52714



52715



52716



52717



KIT DE CHAVES DE CAIXA

REF.												€
51409	0.35	5	50	-	CrV	6 PCS		1/2"	M10, M12, M14, M16, M18, M20			36,00€
51410	0.38	5	50	500	CrV	6 PCS		1/2"	T55, T60, T70, T80, T90, T100			36,00€

51409



51410



PONTA EXTRA-LONGA DE 12 CANTOS 800MM COM SOQUETE 1/2"

REF.									€
52059	0.57	-	25	1750	CrV	1 PCS		Ø 8mm - 800mm	29,00€
52060	0.57	-	25	1750	CrV	1 PCS		Ø 10mm - 800mm	32,00€
53667	0.80	10	20	-	CrV	1 PCS		Ø 12mm - 800mm	32,00€
53668	1.05	10	20	-	CrV	1 PCS		Ø 14mm - 800mm	34,00€



KIT DE CHAVES DE CAIXA

52908 **19,90€**

0.60 8 32 500

1/4" x3 PH0, PH1, PH2 1/4" x4 3, 4, 5, 6mm
 1/4" x3 PZ0, PZ1, PZ2 1/4" x8 T8, T9, T10, T15, T20, T25, T27, T30
 1/4" x4 SL4, SL5.5, SL6.5, SL7 1/4" x8 T8, T9, T10, T15, T20, T25, T27, T30



52909 **14,00€**

0.35 8 32 1500

1/4" x2 PH1, PH2 1/4" x4 3, 4, 5, 6mm
 1/4" x2 PZ1, PZ2 1/4" x7 T8, T10, T15, T20, T25, T27, T30
 1/4" x3 SL4, SL5.5, SL6.5



51746 **12,00€**

0.20 5 75 1050

1/4" x7 TS10, TS15, TS20, TS25, TS30, TS40, TS45



53127 **12,00€**

0.15 5 100 1800

1/4" x7 TS10, TS15, TS20, TS25, TS30, TS40, TS45



54545 **18,00€**

0.35 10 40 960

3/8" x9 4, 5, 6, 7, 8, 9, 10, 12, 14mm



54546 **19,50€**



0.35 10 40 960

3/8" x10 T10, T15, T20, T25, T27, T30, T40, T45, T50, T55



53084 24,00€

0.60 5 20 880
Kg SUB

	1/2"	x3	100mm - T55, T60, T70
	3/8"	x4	90mm - T30, T40, T45, T50

50980 23,50€



0.76 5 20 300
Kg SUB



	1/2"	x3	100mm - M12, M13, M14
	3/8"	x4	90mm - M6, M7, M8, M10

50982 22,00€

0.46 6 36 1080
Kg SUB

	3/8"	x7	100mm - 3, 4, 5, 6, 7, 8, 10mm
--	------	----	--------------------------------

52320 23,00€

0.76 5 20 500
Kg SUB



	1/2"	x3	100mm - M12, M13, M14
	3/8"	x4	90mm - M6, M7, M8, M10

54091 441,00€

4.20 - 3 81
Kg SUB

MALETA DE FERREMENTA ISOLADA - 26PEÇAS



REPOSIÇÕES DISPONÍVEIS



	3/8"	x10	8, 10, 11, 12, 13, 14, 16, 17, 19, 22mm
	3/8"	x1	200mm
	1/2"	x1	125mm
	3/8"	x1	200mm
		x2	4x100, 5x125mmL
		x2	PH1x80, PH2x100mm
		x1	185mm
		x1	
		x6	7x86, 8x99, 10x109, 12x127, 14x141, 17x156mm
		x1	185mm

54093 441,00€

2.88 - 4 64
Kg SUB

MÓDULO EVA DE FERRAMENTA ISOLADA



REPOSIÇÕES DISPONÍVEIS



	3/8"	x10	8, 10, 11, 12, 13, 14, 16, 17, 19, 22mm
	3/8"	x1	200mm
	1/2"	x1	125mm
	3/8"	x1	200mm
		x2	4x100, 5x125mmL
		x2	PH1x80, PH2x100mm
		x1	185mm
		x1	
		x6	7x86, 8x99, 10x109, 12x127, 14x141, 17x156mm
		x1	185mm

CUMPRE COM:

- VDE
- GEPRÜFTE SICHERHEIT
- 1000V 22C IEC 60900 C

CUMPRE COM:

- VDE
- GEPRÜFTE SICHERHEIT
- 1000V 22C IEC 60900 C

32,50€

15162

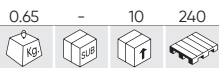

MÓDULO DE 8 CHAVES DE FENDAS ISOLADAS VDE

	x4	0.5x3.0x75, 0.8x4.0x100, 1.0x5.5x125, 1.2x6.5x150mm
	x3	PH0x75, PH1x80, PH2x100mm
	x1	SL3x140mm



REPOSIÇÕES DISPONÍVEIS



CUMPRE COM:

- VDE
- GEPRÜFTE SICHERHEIT
- 1000V 22C IEC 60900 C

53154



MALETA DE FERRAMENTA ISOLADA 20 PEÇAS DE 3/8"

	3/8"	x12	8, 10, 11, 12, 13, 14, 16, 17, 18, 19, 21, 22mm
	3/8"	x1	200mm
	3/8"	x2	125, 250mm
	3/8"	x4	4, 5, 6, 8mm (75mm)

CUMPRE COM:

- VDE
- GEPRÜFTE SICHERHEIT
- 1000V 22C IEC 60900 C

462,00€



52519

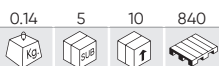

KIT DE 7 CHAVES ISOLADAS ATÉ 1.000V

	x2	PH0x50, PH0x50mm
	x5	SL1.5x0.23x50, SL1.8x0.30x50, SL2.0x0.40x50, SL2.5x0.40x50, SL3.0x0.50x50mm

CUMPRE COM:

- VDE
- GEPRÜFTE SICHERHEIT
- 1000V 22C IEC 60900 C

25,50€



54562

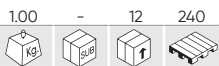

CONJUNTO DE CHAVES DE FENDAS INTERCAMBIÁVEIS 25PCS ISOLADAS

	x3	PH0x75, PH1x100, PH2x100mm
	x3	PZ0x75, PZ1x100, PZ2x100mm
	x6	SL2.5x75, SL3.0x75, SL3.5x75, SL4.0x100, SL5.5x100, SL6.5x100
	x11	T5x75, T6x75, T7x75, T8x75, T9x75, T10x75, T15x75, T20x75, T25x75, T27x75, T30x75mm
	x1	140mm

CUMPRE COM:

- VDE
- GEPRÜFTE SICHERHEIT
- 1000V 22C IEC 60900 C



68,50€

53165

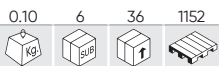

NAVALHA CORTA CABOS ISOLADA (CURVADA)

CUMPRE COM:

- VDE
- GEPRÜFTE SICHERHEIT
- 1000V 22C IEC 60900 C

19,60€

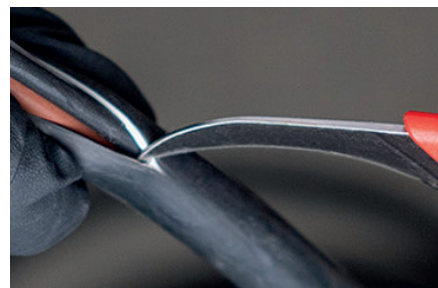

FERRAMENTAS MANUAIS

- 38 CHAVES
- 46 SARGENTOS
- 47 CATRACAS
- 50 CHAVES DINAMOMETRICAS
- 53 BARRAS DE EXTENSÃO
- 54 CHAVES DE FENDAS
- 57 ALICATES
- 65 FERRAMENTAS DE INSPEÇÃO
- 66 MARTELOS
- 67 FERRAMENTAS DE CORTE
- 68 CINZÉIS
- 69 REBITADORES
- 72 FERRAMENTAS DE MEDIÇÃO
- 73 DIVERSOS

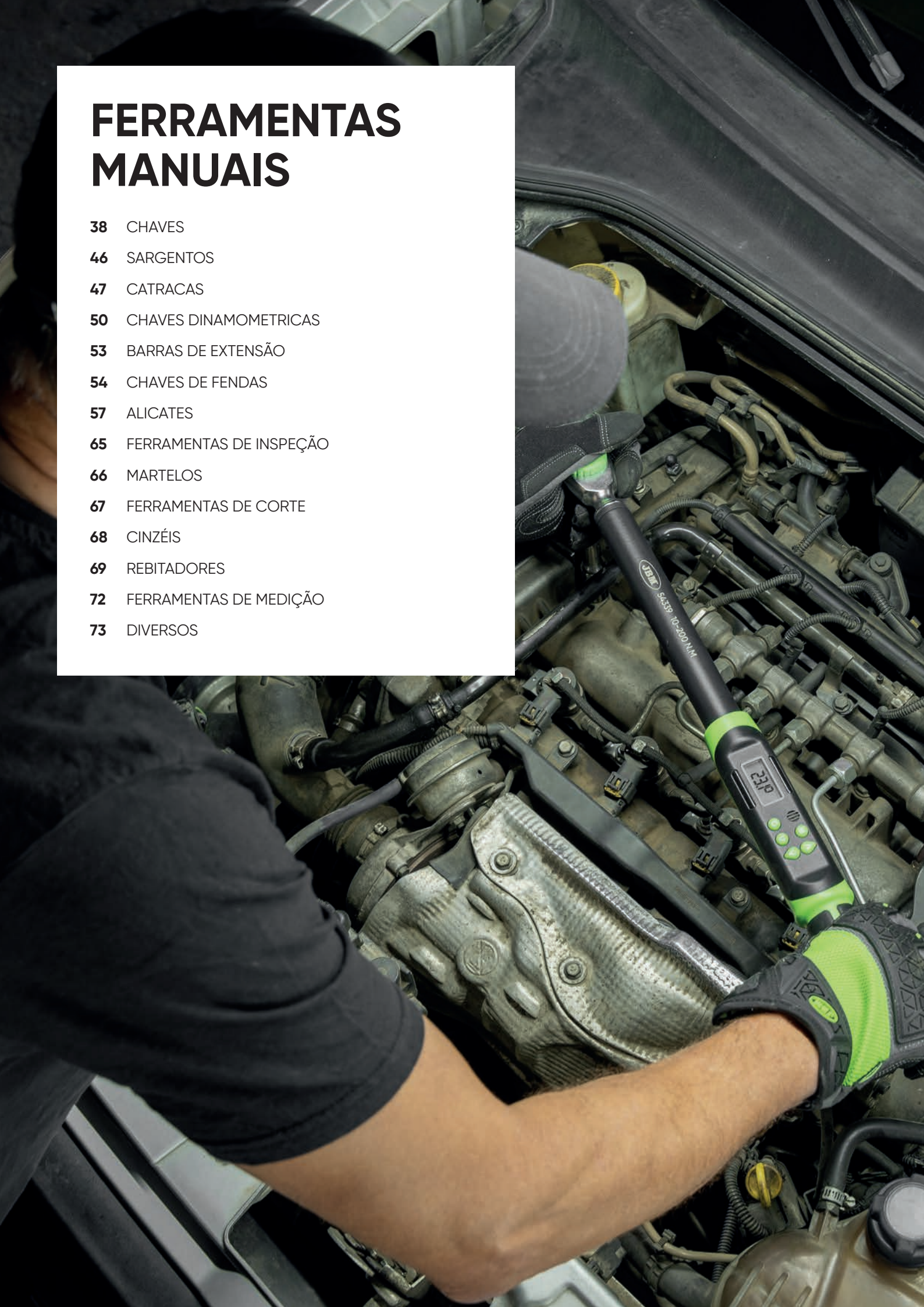

54149

60,00€

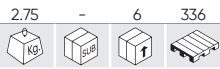

CONJUNTO DE 12 CHAVES FIXAS



REPOSIÇÕES DISPONÍVEIS



54150

24,00€

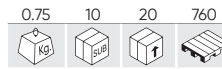

CONJUNTO DE 7 CHAVES FIXAS



REPOSIÇÕES DISPONÍVEIS



54079

83,00€

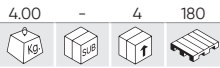

CONJUNTO DE 21 CHAVES COMBINADAS



REPOSIÇÕES DISPONÍVEIS

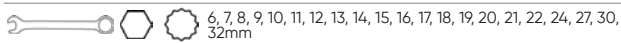

54097

39,00€

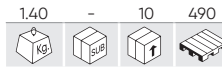

CONJUNTO DE 14 CHAVES COMBINADAS



REPOSIÇÕES DISPONÍVEIS



50564

30,00€

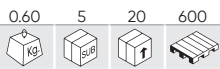

CONJUNTO DE 8 CHAVES COMBINADAS CURTAS



REPOSIÇÕES DISPONÍVEIS



54120

63,00€

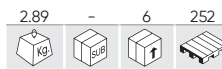

CONJUNTO DE 7 CHAVES COMBINADAS



REPOSIÇÕES DISPONÍVEIS

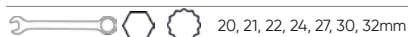

54174

139,00€



CONJUNTO DE 6 CHAVES COMBINADAS

XL



REPOSIÇÕES DISPONÍVEIS



54914

21,00€

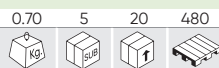

NEW

EXTENSOR UNIVERSAL DE CHAVES 340MM

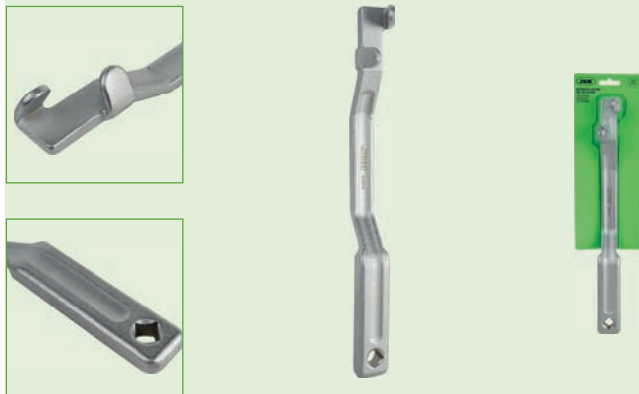

54119

78,00€



CONJUNTO DE 12 CHAVES OFFSET DE 12 PONTOS



REPOSIÇÕES DISPONÍVEIS

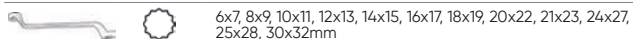

50562

27,00€



CONJUNTO DE 7 CHAVES OFFSET DE 12 PONTOS



REPOSIÇÕES DISPONÍVEIS

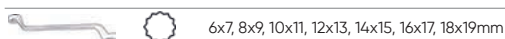

15156

70,00€



MÓDULO EVA COM 4 CHAVES ANGULARES



REPOSIÇÕES DISPONÍVEIS

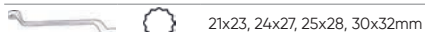
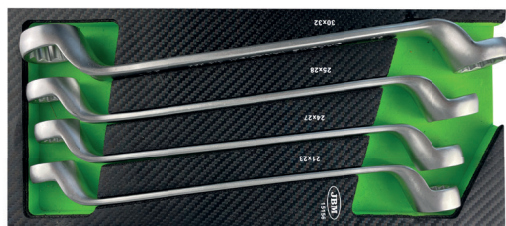

54041

198,00€



CONJUNTO DE 22 CHAVES COMBINADAS COM CATRACA EM MALETA



REPOSIÇÕES DISPONÍVEIS

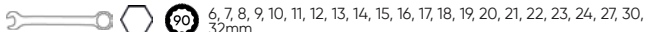

54110

48,50€

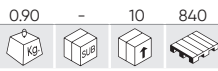

CONJUNTO DE 8 CHAVES COMBINADAS CURTAS COM CATRACA



REPOSIÇÕES DISPONÍVEIS



54117

74,00€

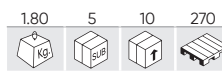

CONJUNTO DE 12 CHAVES COMBINADAS COM CATRACA



REPOSIÇÕES DISPONÍVEIS

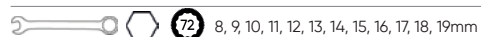

15122

80,00€

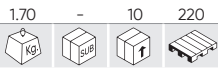

MÓDULO DE CARBONO EVA DE 12 CHAVES COMBINADAS COM ROQUETE



REPOSIÇÕES DISPONÍVEIS



54032

84,00€

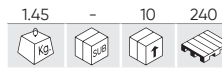

MÓDULO DE 12 MINI CHAVES COMBINADAS ARTICULADAS COM ROQUETE



REPOSIÇÕES DISPONÍVEIS



51318

98,00€

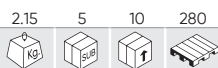

CONJUNTO DE 12 CHAVES COMBINADAS ARTICULADAS COM CATRACA



REPOSIÇÕES DISPONÍVEIS



53017

57,00€



CONJUNTO DE 7 CHAVES COMBINADAS ARTICULADAS COM CATRACA



REPOSIÇÕES DISPONÍVEIS



15316

58,00€

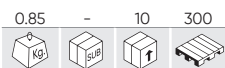

CONJUNTO DE 3 CHAVES COM 72 DENTES - TIPO 4 EM 1



REPOSIÇÕES DISPONÍVEIS



12-13x8-10mm, 14-15x9-11mm, 18-19x16-17mm

54101

65,00€

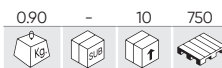

CONJUNTO DE 6 CHAVES COM CATRACA



REPOSIÇÕES DISPONÍVEIS



8x9, 10x11, 12x13, 14x15, 16x18, 17x19mm

54066

83,00€

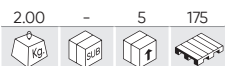

MÓDULO DE 7 CHAVES DE CATRACA EXTRA LONGAS



REPOSIÇÕES DISPONÍVEIS



8, 10, 12, 13, 14, 17, 19mm

53018

127,00€



CONJUNTO DE 6 CHAVES COMBINADAS COM CATRACA ARTICULADAS EM MALA



REPOSIÇÕES DISPONÍVEIS



8x9, 10x11, 12x13, 14x15, 16x18, 17x19mm

51864

69,00€

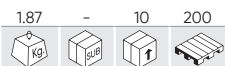

MÓDULO DE 6 CHAVES DE PORCAS EXTRA-LONGAS COM 12 ARESTAS



REPOSIÇÕES DISPONÍVEIS



10x11, 12x14, 13x15, 16x18, 17x19, 22x24mm

52912

94,00€

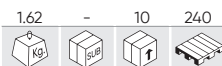

MÓDULO DE 6 CHAVES TORX EXTRA LONGAS



REPOSIÇÕES DISPONÍVEIS



E6xE7, E8xE10, E11xE12, E14xE16, E18xE20, E22xE24

54338

65,00€

0.95 5 20 420

CHAVE DE ROQUETE COM CABEÇA INTERMUTÁVEL 12 PEÇAS



REPOSIÇÕES DISPONÍVEIS



72 8, 9, 10, 11, 12, 13, 14, 15, 16, 17, 18, 19mm

54159

49,50€

1.05 - 10 500

CONJUNTO DE 8 CHAVES EM C DE 12 PONTOS



REPOSIÇÕES DISPONÍVEIS



6x7, 8x9, 10x11, 12x13, 14x15, 16x17, 18x19, 20x22mm

53420

76,00€

1.50 - 20 360

CONJUNTO DE 8 CHAVES DE TUBO



REPOSIÇÕES DISPONÍVEIS



6x7, 8x9, 10x11, 12x13, 14x15, 16x17, 18x19, 20x22mm

51528

54,00€

3.55 - 5 270

CONJUNTO DE 14 CHAVES DE CAIXA DE DUPLA EXTREMIDADE



REPOSIÇÕES DISPONÍVEIS



8, 9, 10, 11, 12, 13, 14, 15, 16, 17, 18, 19, 20, 21mm

54115

29,00€

0.35 - 50 500

CONJUNTO DE 4 CHAVES TORX PLANAS



REPOSIÇÕES DISPONÍVEIS



E6xE8, E10xE12, E14xE18, E20xE24

54081

28,00€

0.75 - 10 960

CONJUNTO DE 5 CHAVES HEXAGONAIS DE BOCA ABERTA COM 6 BORDAS



REPOSIÇÕES DISPONÍVEIS



10x11, 12x13, 14x15, 16x17, 18x19mm

53654

81,00€

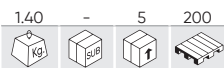

CONJUNTO DE 3 CHAVES DE GANCHO COM 3 ADAPTADORES



	160, 177, 250mm
	35-60, 60-90, 90-120mm

54187

42,50€

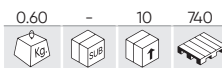

CONJUNTO DE 10 CHAVES CROWFOOT 3/8"



	10, 11, 13, 14, 15, 16, 17, 18, 19, 22mm
--	--

53979

38,00€

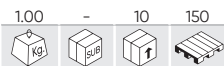

CONJUNTO DE 8 CHAVES TORX EM FORMA DE "T" EM MÓDULO



	T10x75, T15x75, T20x100, T25x100, T30x150, T40x150, T45x200, T50x200
--	--

53980

38,00€

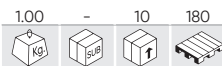

MÓDULO DE 8 CHAVES ALLEN EM FORMA DE "T"



	H2x100, H2.5x100, H3x100, H4x150, H5x150, H6x200, H8x200, H10x200
--	---

54481

113,00€

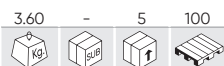

MÓDULO DE 7 CHAVES DE CAIXA COM CABO EM T (7-19 MM)



	7, 8, 10, 11, 13, 17, 19mm (465mm)
--	------------------------------------

54380

119,00€



CONJUNTO DE 9 CHAVES DE SOQUETE COM CABO EM T (7-19 MM)



	7, 8, 10, 11, 13, 14, 15, 17, 19mm (465mm)
--	--

51659

59,00€

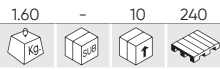

ESTOJO COM 6 CHAVES DE SOQUETE ARTICULADAS DE 12 PONTOS



REPOSIÇÕES DISPONÍVEIS

8x9, 10x11, 12x13, 14x15, 16x17, 18x19mm

50622

70,00€

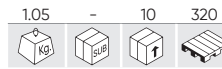

ESTOJO COM 4 CHAVES DE SOQUETE TORX ARTICULADAS



REPOSIÇÕES DISPONÍVEIS

E6xE8, E10xE12, E14xE18, E20xE24

CONJUNTO DE 9 BOCAIS

TORX

REF.	PCS	mm	CONTÉM	kg	vol	vol	vol	€
53737	9	90-218mm	T10, T15, T20, T25, T27, T30, T40, T45, T50	0.42	10	40	600	12,80€
53739	9	86-150mm	T10, T15, T20, T25, T27, T30, T40, T45, T50	0.32	10	40	960	10,50€
53955	9	44-100mm	T10, T15, T20, T25, T27, T30, T40, T45, T50	0.25	10	40	1480	10,00€

HEXAGONAIS

REF.	PCS	mm	CONTÉM	kg	vol	vol	vol	€
53738	9	90-220mm	1.5, 2, 2.5, 3, 4, 5, 6, 8, 10mm	0.45	10	40	1000	10,90€
53740	9	72-170mm	1.5, 2, 2.5, 3, 4, 5, 6, 8, 10mm	0.37	10	40	960	9,90€
53954	9	43-97mm	1.5, 2, 2.5, 3, 4, 5, 6, 8, 10mm	0.25	10	40	1480	9,40€

NOVO DESIGN

REF.	PCS	mm	CONTÉM	kg	vol	vol	vol	€
54531	9	90-220mm	1.5, 2, 2.5, 3, 4, 5, 6, 8, 10mm	0.48	10	40	1120	14,90€
54532	9	90 - 218mm	T10, T15, T20, T25, T27, T30, T40, T45, T50	0.49	10	40	1120	14,90€



53737 - 53739 - 53955

53738 - 53740 - 53954

54531

54532

CHAVE DE GRIFO

REF.	"	mm						€
52235	12"	300mm	50mm	0.90	6	24	1140	11,50€
52236	14"	350mm	60mm	1.09	6	24	760	14,30€
52237	18"	450mm	70mm	1.75	4	12	720	18,00€
52238	20"	510mm	75mm	2.50	2	8	600	26,50€
53210	36"	915mm	110mm	4.95	-	4	96	48,00€



REF.	"	mm						€
53070	12"	270mm	45mm	0.68	6	24	900	17,30€
53071	14"	320mm	50mm	0.92	4	12	900	27,50€
53072	18"	410mm	65mm	1.35	4	12	900	34,00€
53073	24"	540mm	75mm	2.05	2	8	1000	50,00€



CHAVE INGLESA

MODELO 1

REF.	"	mm						€
51798	18"	450mm	53mm	1.90	3	12	432	39,60€
52424	24"	610mm	62mm	3.75	-	5	350	64,00€



MODELO 2

REF.	"	mm						€
51795	8"	200mm	22mm	0.28	6	60	3600	9,00€
51796	10"	250mm	28mm	0.48	6	36	2400	14,00€
51797	12"	300mm	37mm	0.71	6	24	960	18,00€



MODELO 3

REF.	"	mm						€
53639	6"	150mm	28mm	0.15	6	96	576	28,60€
53640	8"	200mm	30mm	0.28	6	72	504	34,40€
53641	10"	250mm	33mm	0.50	6	36	1151	41,00€
53642	12"	300mm	40mm	0.83	6	24	1200	54,00€
53643	16"	400mm	52mm	1.53	-	12	336	92,00€
54098	20"	640mm	65mm	2.70	-	6	-	158,50€



FERRAMENTAS EM POLEGADA

51890

97,00€



CONJUNTO DE 17 CHAVES COMBINADAS (POLEGADAS)



5/16, 3/8, 7/16, 1/2, 9/16, 19/32, 5/8, 11/16, 3/4, 13/16, 7/8, 15/16, 1", 1" 1/16, 1" 1/8, 1" 3/16, 1" 1/4

54005

14,00€

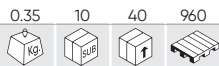

CONJUNTO DE 9 CHAVES ALLEN DE PONTA REDONDA (POLEGADAS)



1/16", 5/64", 3/32", 1/8", 5/32", 3/16", 1/4", 5/16", 3/8"
69, 75, 82, 91, 103, 118, 133, 155, 177mm

54106

89,00€



MALA DE FERRAMENTAS EM POLEGADAS ZINCADA COM 37 PEÇAS



1/2" x17	5/16", 3/8", 7/16", 1/2", 9/16", 19/32", 5/8", 11/16", 3/4", 13/16", 7/8", 15/16", 1", 1-1/16", 1-1/8", 1-3/16", 1-1/4"
1/4" x8	3/16", 7/32", 1/4", 9/32", 5/16", 11/32", 3/8", 7/16"
1/2" x2	16, 21mm
1/2" x2	5", 10"
1/4" x1	3"
1/4" x1	16, 21mm
1/4" x1	1/4" x1
1/2", 1/4" x2	12
1/2", 1/4" x2	
1/2", 1/4" x1	

SARGENTO

REF.	mm					€
52349	90x200mm	1.25	-	10	480	24,00€
52350	90x300mm	1.41	-	10	540	24,50€
52351	90x400mm	1.60	-	10	480	27,50€
52352	120x300mm	1.99	-	10	360	35,00€
52353	120x400mm	2.10	-	10	350	36,00€
52354	120x500mm	2.41	-	6	300	36,50€
52355	120x600mm	2.62	-	4	300	39,00€
52357	150x800mm	4.60	-	4	125	54,00€
52358	150x1000mm	5.35	-	5	120	67,00€



ROQUETE DE 72 DENTES

PADRÃO

REF.	"	mm	ACABADO					€
54022	1/4"	145mm	Cromado	0.15	12	36	2016	10,00€
54023	3/8"	200mm	Cromado	0.30	12	24	1440	14,00€
54024	1/2"	255mm	Cromado	0.60	12	24	960	18,00€
54018	1/4"	145mm	Zincado	0.15	12	36	2340	10,00€
54021	3/8"	200mm	Zincado	0.28	12	24	12000	14,00€
54019	1/2"	255mm	Zincado	0.60	12	24	864	18,00€

EM EXPOSITOR DE 12 UDS

RETO

REF.	"	mm	ACABADO					€
54083	1/4"	145mm	Zincado	0.14	12	24	2592	10,50€
54084	3/8"	200mm	Zincado	0.30	12	24	1440	14,10€
54085	1/2"	255mm	Zincado	0.60	12	24	960	19,20€

EM EXPOSITOR DE 12 UDS

CABEÇA GIRATÓRIA

REF.	"	mm	ACABADO					€
51405	1/4"	145mm	Zincado	0.58	12	24	-	21,10€
51406	1/2"	280mm	Cromado	0.66	12	24	864	29,20€

EM EXPOSITOR DE 12 UDS

EXTENSÍVEL

REF.	"	mm	ACABADO					€
53346	1/4"	150-200mm	Zincado	0.25	6	12	-	18,30€
51307	1/2"	305-445mm	Zincado	0.92	6	12	396	29,70€
54304	1/2"	450-610mm	Zincado	1.15	-	6	480	29,00€

EM EXPOSITOR DE 6 UDS

RETO COMPACTO

REF.	"	mm	ACABADO					€
54086	1/4"	105mm	Zincado	0.10	12	36	-	10,00€
54087	1/2"	173mm	Zincado	0.50	12	24	1008	18,60€

EM EXPOSITOR DE 12 UDS

MINI

REF.	"	mm	ACABADO					€
52207	1/4"	85mm	Zincado	0.05	12	240	4320	24,20€

EM EXPOSITOR DE 12 UDS



54022
54023
54024



54018
54019
54021



ROQUETE DE 72 DENTES

ARTICULADO ALONGADA

REF.	"	mm	ACABADO					€
53886	1/4"	305mm	Zincado	0.27	10	40	1680	22,00€
53887	3/8"	457mm	Zincado	0.68	10	20	700	33,50€
53888	1/2"	609mm	Zincado	1.27	4	16	480	40,50€



53886
53887
53888

53883
53884
53885

ALONGADA

REF.	"	mm	ACABADO					€
53883	1/4"	305mm	Zincado	0.27	10	40	1680	19,80€
53884	3/8"	457mm	Zincado	0.61	10	20	700	32,50€
53885	1/2"	609mm	Zincado	1.25	4	16	480	35,70€

ARTICULADO

REF.	"	mm	ACABADO					€
52588	1/2"	172mm	Cromado	0.17	12	144	3456	47,50€

EM EXPOSITOR DE 12 UDS



ARTICULADO PEQUENO

REF.	"	mm	ACABADO					€
51306	1/4"	165mm	Cromado	0.30	12	48	816	23,50€
51305	1/2"	175mm	Cromado	0.31	12	48	816	23,50€

EM EXPOSITOR DE 12 UDS



ARTICULADA EXTENSÍVEL

REF.	"	mm	ACABADO					€
52197	1/2"	350-490mm	Zincado	1.04	6	12	468	36,30€

EM EXPOSITOR DE 6 UDS



CONJUNTO DE 3 ROQUETES CURTOS

REF.	"	mm	ACABADO					€
53671	1/4"	85mm	Cromado	0.85	-	10	520	41,00€
	3/8"	102mm	Cromado					
	1/2"	135mm	Cromado					



ROQUETE DE 72 DENTES

NEW FLEXÍVEL

REF.	"	mm	ACABADO					€
54691	1/4"	165mm	Zincado	0.15	25	100	9800	17,50€
54694	3/8"	250mm	Zincado	0.39	25	100	3200	20,50€



COM CHAVES

REF.	"	ACABADO	PERFIL	COM CHAVES					€
54028	1/2"	Zincado		10, 11, 12, 13, 14, 15, 16, 17, 18, 19mm	1.30	4	24	432	29,00€
54029	1/2"	Zincado			1.25	4	24	432	29,00€
54030	1/4"	Zincado		4, 5, 6, 7, 8, 9, 10, 11, 12, 13mm	0.35	6	36	1008	19,00€
54031	1/4"	Zincado			0.35	6	36	864	19,00€

54028



REPOSIÇÕES DISPONÍVEIS



54029



REPOSIÇÕES DISPONÍVEIS



54030



REPOSIÇÕES DISPONÍVEIS



54031



REPOSIÇÕES DISPONÍVEIS



ROQUETE DE 120 DENTES

REF.	"	Nm	ACABADO					€
54647	1/4"	100Nm	Zincado	0.35	12	24	3024	18,00€
54648	3/8"	360Nm	Zincado	1.90	12	24	1320	19,00€
54649	1/2"	900Nm	Zincado	1.90	12	24	1056	24,00€

54647



REPOSIÇÕES DISPONÍVEIS

54648



REPOSIÇÕES DISPONÍVEIS

54649



REPOSIÇÕES DISPONÍVEIS



EM EXPOSITOR DE 12 UDS

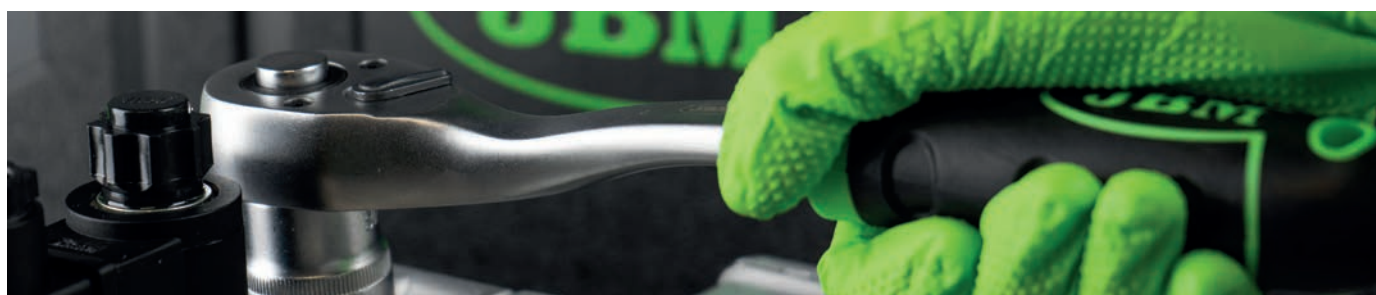

VOCÊ PODE GOSTAR...

PEÇA DE REPOSIÇÃO

REF.							€
15147	3/8"	REF.53884, 53887	0.10	-	100	-	6,60€
15148	1/2"	REF.53885, 53888	0.20	-	100	-	6,60€
15149	1/4"	REF.53883, 53886	0.05	-	100	-	6,60€

KIT DE REPARO PARA CHAVE CATRACA

REF.							€
15138	1/4"	REF.53671, 54030, 54031, 54022, 54018, 54083, 54086	0.10	-	50	-	11,70€
15139	3/8"	REF.53671, 54023, 54021, 54084	0.06	-	50	-	13,70€
15140	1/2"	REF.53671, 54028, 54029, 54024, 54019, 54085, 54087	0.20	-	50	-	15,60€



CHAVE ARTICULADA

REF.	"	mm					€
52524	3/4"	1020mm	3.60	3	6	168	56,00€
52526	1/2"	600mm	1.65	5	10	500	28,40€
52525	1/2"	430mm	0.85	5	25	1500	14,00€
54343	1/2"	450-600mm	1.15	-	6	594	33,00€



ADAPTADOR DE ENCAIXE

REF.	"	mm					€
53468	1/2"	250mm	0.35	6	48	600	9,20€
53478	1/4"	115mm	0.50	5	100	1200	5,00€
53479	3/8"	200mm	0.15	5	50	300	6,50€
53480	3/4"	460mm	1.35	5	10	480	20,50€
53481	1"	550mm	2.85	-	5	300	30,00€



54870

229,00€

	2.61	-		6		150
--	------	---	--	---	--	-----

NEW

CHAVE DE TORQUE DIGITAL 1/2" 17-340NM

Peças	1
Medida do quadrado	1/2"
Faixa de torque	17-340Nm
Precisão (sentido horário)	±2%
Precisão (sentido anti-horário)	±3%
Unidades de medida	Nm, In/Lb, Ft/Lb, Kg/cm
Comprimento	669mm
Peso	1,57Kg



54339

273,00€

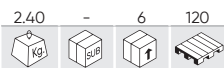

CHAVE DE TORQUE DIGITAL 1/2" COM FAIXA DE 10-200 NM

Peças	1
Medida do quadrado	1/2"
Medição	0-360° (Torque-Grados/Degrees)
Faixa de torque	10-200Nm
Precisão (sentido horário)	±2%
Precisão (sentido anti-horário)	±3%
Unidades de medida	Nm, In/Lb, Ft/Lb, Kg/cm, Grados/Degrees
Comprimento	530mm
Peso	2,40Kg



VÍDEO TUTORIAL



53972

550,00€



CHAVE DE TORQUE 3/4" EXTENSÍVEL, 200-800NM

Peças	1
Medida do quadrado	3/4"
Material	Acero/Steel - SMC440
Número de dentes	72
Faixa de torque	200-800Nm
Precisão (sentido horário)	±3%
Unidades de medida	Nm
Comprimento	1000-1210mm
Peso	8,75Kg



52913

292,00€

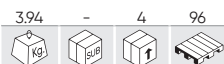

CHAVE DE TORQUE 1/2" COM 40-200 NM E CABEÇAS INTERCAMBIÁVEIS

Peças	11
Medida do quadrado	1/2"
Material	Cr-V
Número de dentes	72
Faixa de torque	40-200Nm
Precisão (sentido horário)	±3%
Unidades de medida	Nm
Comprimento	325mm
Peso	3,94Kg



REPOSIÇÕES DISPONÍVEIS



54785

130,00€



NEW

CONJUNTO DE FERRAMENTAS DE 5 PEÇAS COM CHAVE DINAMOMÉTRICA 1/2" COM MIRILHA

Peças	5
Medida do quadrado	1/2"
Material	Cr-V, CR-Mo
Faixa de torque	20-200Nm
Precisão (sentido horário)	3%
Unidades de medida	Nm, Lb.ft
Dimensões (CxLxA)	540x70x80mm
Peso	1,90Kg



VÍDEO TUTORIAL



REPOSIÇÕES DISPONÍVEIS



54269

56,00€



CONJUNTO DE 21 PONTAS E ADAPTADORES 1/4" COM CHAVE DE TORQUE

	x1	5-25Nm		x3	PH1, PH2, PH3
	x1	100mm		x8	H2, H2.5, H3, H4, H5, H6, H8, H10 (37mmL)
	x1	UNIVERSAL		x1	H5 (87mmL)
	x1	1/4" (F) - 3/8" (M)		x5	T10, T15, T20, T25, T30



REPOSIÇÕES DISPONÍVEIS



CHAVE DINAMOMÉTRICA COM O APROFUNDAMENTO

REF.	"	mm	Nm					€
53081	1/4"	375mm	4-20Nm	1.10	5	25	350	115,00€
53082	1/2"	560mm	40-210Nm	1.90	4	8	168	148,00€



53081

53082

NEW CHAVE DINAMOMÉTRICA COM O APROFUNDAMENTO

REF.	"	mm	Nm					€
54853	1/4"	245mm	1-5Nm	0.74	-	10	360	69,00€
54529	1/4"	280mm	3-25Nm	0.78	-	10	520	84,00€
54696	3/8"	420mm	20-120Nm	0.39	25	50	260	90,00€
54530	1/2"	515mm	20-200Nm	1.90	-	10	210	105,00€
54783	1/2"	515mm	60-320Nm	1.90	-	4	208	116,50€
54855	1/2"	670mm	80-420Nm	2.63	-	4	112	136,00€
54857	3/4"	1210mm	150-750Nm	8.26	-	2	42	599,00€
54858	1"	1400mm	200-1000Nm	9.02	-	2	42	749,00€



54853

54529

54696

54530

54783

54855

54857

54858

CHAVE DINAMOMÉTRICA

REF.	"	mm	Nm					€
54526	1/4"	235mm	5-25Nm	0.71	5	10	380	41,00€
54533	3/8"	420mm	20-120Nm	1.54	5	10	220	56,00€
54527	1/2"	430mm	40-210Nm	1.69	5	10	200	64,00€



CHAVE DINAMOMÉTRICA

REF.	"	mm	Nm					€
51262	1/4"	270mm	5-25Nm	0.80	4	16	448	51,00€
51338	3/8"	365mm	19-110Nm	1.05	4	16	352	53,00€
51127	1/2"	470mm	28-210Nm	1.70	4	8	256	56,00€

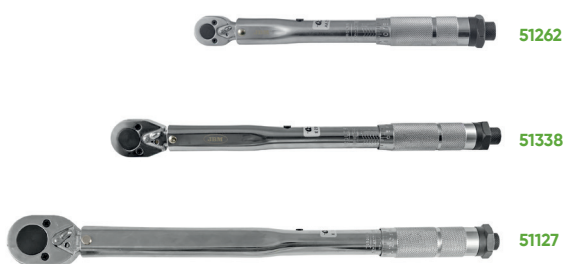

KIT EXTENSOR

REF.	"	PÉ	PCS	mm					€
51805	1/4"	Pé redondo	5 PCS	50, 75, 100, 152, 227mm	0.33	4	20	640	17,00€
51447	1/4"	Pé normal	5 PCS	50, 75, 100, 152, 227mm	0.34	5	20	960	16,00€
51448	1/2"	Pé redondo	5 PCS	50, 125, 250, 380, 510mm	2.38	-	5	270	52,00€

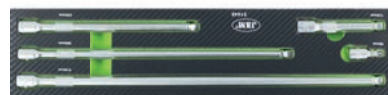

51805

REPOSIÇÕES DISPONÍVEIS

51447

REPOSIÇÕES DISPONÍVEIS

51448

REPOSIÇÕES DISPONÍVEIS

51479 **34,00€**

0.65 12 24 1056

BARRA EXTENSÍVEL 1/2", 260-410 MM



1/2" 260-410mm



EM EXPOSITOR DE 12 UDS

54684

23,50€

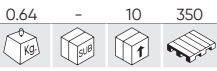

CONJUNTO DE 4 CHAVES TORX EXTRALONGAS

450mm T15, T20, T25, T30



REPOSIÇÕES DISPONÍVEIS

54302

13,80€

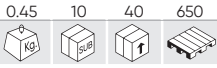

CONJUNTO COM 6 CHAVES DE FENDA DE PRECISÃO

x3 PH00, PH0, PH1
x3 SL2, SL3, SL4



CHAVE DE FENDA EVA - ACABAMENTO DE CARBONO

REF.	PCS	mm					€
53943	7 PCS	PH4x200, PH3x150, PH2x100, PH2x38, PH1x80, PH1x100, PH0x120	0.80	-	10	240	23,50€
53944	7 PCS	SL9x200, SL4x125, SL5x100, SL5x80, SL6x38, SL6x100, SL8x150	0.80	-	10	240	22,50€
53945	7 PCS	T8x75, T9x75, T10x75, T15x75, T20x75, T25x100, T27x100	0.60	-	10	240	21,00€

53943



REPOSIÇÕES DISPONÍVEIS



53944



REPOSIÇÕES DISPONÍVEIS



53945



REPOSIÇÕES DISPONÍVEIS



KIT DE CHAVES

REF.	PCS	mm					€
52500	3 PCS	PH00x25, PH0x25, PH1x25	0.33	-	50	1000	19,50€
	5 PCS	SL0.4x2x25, SL0.4x2.5x25, SL0.5x3.0x25, SL0.5x3.5x25, SL0.8x4x25					
53917	3 PCS	PH00, PH0, PH1	0.20	5	50	950	9,60€
	4 PCS	SL1.4, SL2.0, SL2.4, SL3.0					



52500



53917

53694

19,00€

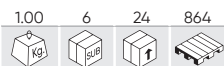

ESTOJO METÁLICO COM CHAVE DE IMPACTO 1/2" E CONJUNTO DE 6 PONTAS



	x3	PH2x36, PH3x36, PH3x70		x1	1/2"
	x3	SL7x36, SL8x36, SL8x70		x1	1/2"

54126

44,00€



MALETA COM 12 CHAVES DE FENDA GO-THROUGH COM PONTA MAGNÉTICA

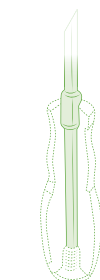

GO-THROUGH

	x6	PH1x75, PH2x38, PH2x100, PH3x150, PH4x200 (GO-THROUGH), PH0x75mm
	x6	SL5x75, SL6x38, SL6x100, SL8x150, SL9.5x200 (GO-THROUGH), SL3.2x75mm



REPOSIÇÕES DISPONÍVEIS

53010

18,00€

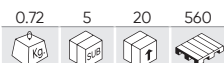

CONJUNTO DE CHAVES DE FENDA 20 EM 1 COM CABO E PONTAS DUPLAS INTERCAMBIÁVEIS



	x2	PH1, PH2		x3	T10x15, T20x25, T30x40
	x2	4x6, 5x7mm		x3	H4x4, H5x5, H6x6mm

54551

11,50€

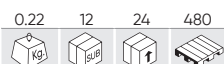

CHAVE DE FENDAS CURTA COM CATRACA 6 EM 1



	x2	4, 5mm
	x2	PH1, PH2
	x2	PZ1, PZ2



EM EXPOSITOR DE 12 UDS

54552

15,00€

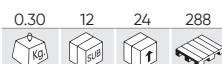

CHAVE DE FENDAS COM CATRACA 12 EM 1



	x3	4, 5, 6mm
	x3	PH1, PH2, PH3
	x3	3, 4, 5mm
	x3	T15, T20, T25



EM EXPOSITOR DE 12 UDS



VÍDEO TUTORIAL

CONJUNTO DE 6 CHAVES DE FENDA

REF.		PCS	mm					€
54070		2 PCS	PH1x80, PH2x100mm	0.50	-	10	440	18,00€
		4 PCS	SL6.5x150, SL5.5x125, SL4x100, SL3x80mm					
54071		3 PCS	PH3x150, PH2x100, PH1x75mm	1.10	-	10	330	26,50€
		3 PCS	SL8x150, SL6.5x100, SL5.5x75mm					

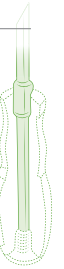

CHAVE COM MULTIFUNÇÃO ESTRELA E FENDA

REF.		PCS	mm					€
54060		2 PCS	SL6x150, PH2x150mm	0.15	10	60	1500	6,00€
54061		2 PCS	SL6x100, PH2x100mm	0.10	10	60	1800	6,00€



54060



54061



CHAVE FLEXÍVEL

REF.		PCS	"							€
52169		4 PCS	1/4"	265mm	6, 7, 8mm	0.45	12	48	432	25,00€
52170		7 PCS	1/4"	265mm	4, 5, 6, 7, 8, 10mm	0.27	12	48	864	16,00€
53575		4 PCS	1/4"	500mm	4, 5, 7mm	0.40	10	40	480	16,00€



52169



52170



53575



50902

13,00€

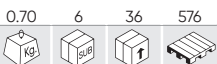

JOGO DE 4 CHAVES DE FENDA DE IMPACTO



	3"	80mm		6"	155mm
	4"	100mm		8"	200mm

53225

4,00€

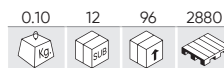

MAGNETIZADOR/DESMAGNETIZADOR



ALICATE SEEGER BOCA RETA

REF.		"	mm					€
51018	PARA INTERIORES	7"	180mm	0.14	5	100	2000	7,20€
52964		9"	225mm	0.23	6	60	1440	9,45€
53549		13"	330mm	0.45	5	30	-	14,80€
51017	PARA EXTERIORES	7"	180mm	0.17	5	100	1800	6,90€
52966		9"	225mm	0.28	6	60	1800	9,90€
53547		13"	330mm	0.50	5	30	-	16,20€

ALICATE SEEGER BOCA CURVA

REF.		"	mm					€
51021	PARA INTERIORES	7"	180mm	0.16	5	100	-	7,20€
52965		9"	225mm	0.24	6	60	1440	9,45€
53550		13"	330mm	0.45	5	30	-	14,80€
51020	PARA EXTERIORES	7"	180mm	0.13	5	100	1600	6,90€
52967		9"	225mm	0.24	6	60	1440	9,90€
53548		13"	330mm	0.50	5	30	-	16,20€



51018, 52964, 53549



51021, 52965, 53550



51017, 52966, 53547



51020, 52967, 53548

15454

35,40€

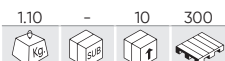

MÓDULO EVA DE ALICATES SEEGER 8" (200MM)



PARA INTERIORES



PARA EXTERIORES



REPOSIÇÕES DISPONÍVEIS



53389

34,00€

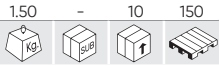

CONJUNTO DE ALICATES SEEGER COM PONTAS INTERCAMBIÁVEIS EM MALA DE TRANSPORTE



	x4	0°, 15°, 45°, 90°
	x4	0°, 15°, 45°, 90°
	x2	260mm

51812

48,00€

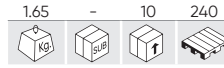

JOGO DE 5 ALICATES (EM ESTOJO)



REPOSIÇÕES DISPONÍVEIS

	x1	160mm		x1	200mm
	x1	160mm		x1	250mm
	x1	180mm			

ALICATE DE CORTE DIAGONAL

REF.	"	mm					€
53905	6"	160mm	0.20	6	60	1080	7,60€
53906	7"	180mm	0.20	6	60	1440	8,65€



ALICATE DE CORTE DIAGONAL

REF.	"	mm					€
55149	6"	160mm	0.25	6	60	1620	9,00€
54711	7"	180mm	0.25	6	60	1620	11,50€







NOVO DESIGN

NEW ALICATE DE BICO FINO

REF.	"	mm					€
54697	8"	200mm	0.21	-	50	3000	10,50€







ALICATE DE PONTA ALARGADA

REF.	"	mm					€
53908	6"	160mm	0.15	6	60	1440	7,80€
53909	8"	200mm	0.20	6	60	1440	9,90€







ALICATE DE PONTA ALARGADA

REF.	"	mm					€
54709	8"	200mm	0.22	6	60	1620	10,50€







ALICATE UNIVERSAL

REF.	"	mm					€
53911	6"	160mm	0.20	6	60	1080	9,00€
54015	7"	180mm	0.20	6	60	1440	10,20€
53967	8"	200mm	0.30	6	60	1440	11,00€









ALICATE UNIVERSAL

REF.	"	mm					€
54710	7"	180mm	0.25	6	60	1620	11,00€









ALICATE EXTENSÍVEL

REF.							€
50567	250mm	40mm	0.34	10	60	1500	9,60€
52052	515mm	140mm	1.88	2	10	400	57,00€



ALICATE EXTRA-LONGO

REF.								€
52846	340mm	85mm	0°	0.40	6	60	1500	37,80€
52847	335mm	75mm	45°	0.40	-	60	1500	42,50€



52272

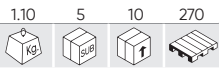

JOGO ALICATES PONTA 0°, 45°, 90°

	0°	280mm
	45°	275mm
	90°	270mm

25,00€



ALICATE PARA ABRAÇADEIRAS

REF.		mm					€	
52619		20mm	260mm	0.55	6	36	648	23,10€
52812		34mm	270mm	0.85	10	20	360	65,00€



ALICATE PARA ABRAÇADEIRAS

REF.							€		
51995			47mm	630mm	0.53	5	40	480	24,50€
53390			50mm	630mm	1.00	10	20	480	34,50€



ALICATE ABRAÇADEIRAS

REF.		mm					€	
52508		0-38mm	240mm	0.37	10	50	800	41,00€
52509		22-55mm	240mm	0.39	10	50	800	38,50€



52050

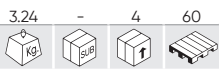

CONJUNTO DE ALICATES DE PRESSÃO NUM ESTOJO DE TRANSPORTE

98,00€



REPOSIÇÕES DISPONÍVEIS



53396 18,30€

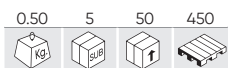

ALICATE PARA ABRAÇADEIRAS DE TUBOS DE ESCAPE

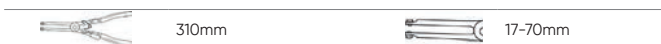

52791 18,00€

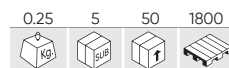

ALICATE PARA ABRAÇADEIRAS CLIC-R



54376 12,80€

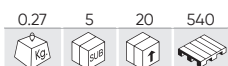

FERRAMENTA PARA ABRAÇADEIRA DA COIFA DA JUNTA HOMOCINÉTICA COM CORTADOR



54311 15,00€

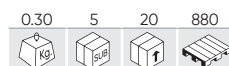

ALICATE PARA ABRAÇADEIRAS



54330 13,70€

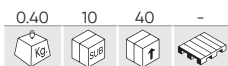

ALICATE DE VEDAÇÃO DA HASTE DA VÁLVULA



54279 6,00€

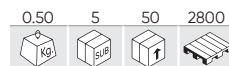

ALICATES PARA EXTRAÇÃO DE LÂMPADAS

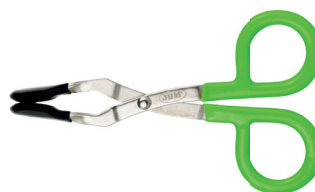

54479 38,50€

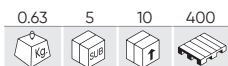

ALICATE PARA CINTAS METÁLICAS COM TRAVAMENTO AUTOMÁTICO



Largura da braçadeira	4.6-12mm
Espessura da braçadeira	0.2-0.4mm

52412 5,90€

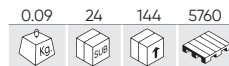

MINI ALICATE MULTIUSOS 105MM



- x2 Chaves de fenda plano
- x1 Ponta estrela
- x1 Sacca-ralhas
- x1 Abre-latas
- x1 Lima 25mm
- x1 Folha de serra 40mm
- x1 Folha de corte 40mm

51355

19,00€

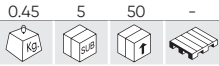

ALICATES DE EQUILÍBRIO DE PESO



52625

9,00€

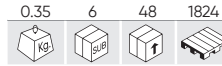

ALICATE PARA MOLAS DE TRAVÃO

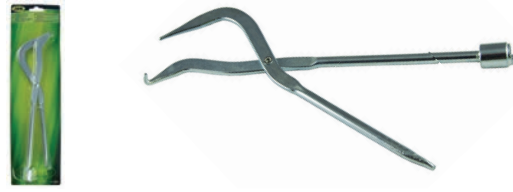

52982

55,00€

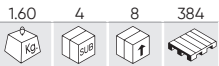

JOGO 3 MORDAÇAS DE PRESSÃO EXTRA-LARGAS

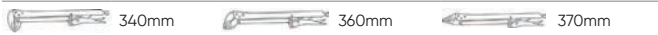

53445

17,10€

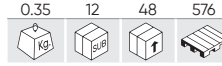

JOGO DE ALICATES PARA DESCONEXÃO DO TUBO DE COMBUSTÍVEL



■ 5/16" Ø 8mm ■ 3/8" Ø 10mm ■ Aplicação especial

FIAT, FORD, OPEL, PEUGEOT, RENAULT, CITROËN, VW

ALICATE DE CORTE DIAGONAL

REF.							€
53411	130mm	13mm	0.05	12	120	-	5,00€
53412	78mm	19mm	0.05	12	120	-	4,00€



53411

53412

53487

18,50€

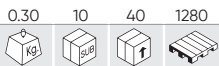

CLEȘTE PENTRU TUB DE COMBUSTIBIL

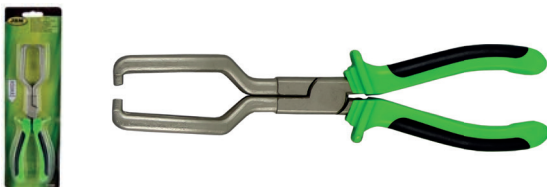

51972

12,00€

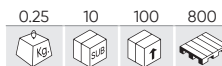

ALICATE PARA DESENCAPAR FIOS AUTO-AJUSTÁVEL

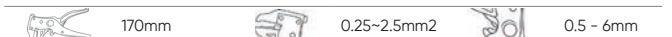

52152 13,50€

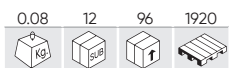

TESOURAS DE ELECTRICISTA ZEBRA



145mm



45mm

54698 12,50€

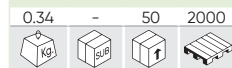

NEW

TESOURA DE PONTA RETA



210mm



50mm

NEW **ALICATE DE CORTE**

REF.	CORTE	CAPACIDADE DE CORTE	LÂMINA DE CORTE	LUNGIME						€
54777	RETO	1,2mm	36-38mm	250mm	0.42	5	20	1400		14,90€
54778	DIREITA	1,2mm	36-38mm	250mm	0.42	5	20	1400		14,90€
54779	ESQUERDA	1,2mm	36-38mm	250mm	0.42	5	20	1400		14,90€



54777



54778



54779

CORTA CAVILHAS

REF.	mm	Ø						€
52955	12"	300mm	0.77	-	10	200		22,00€
52956	14"	350mm	0.95	-	20	200		22,50€
52957	18"	450mm	1.47	-	10	360		25,50€
52958	24"	600mm	2.40	-	8	248		31,50€
52959	30"	750mm	3.78	-	5	100		45,50€
52960	36"	900mm	5.15	-	5	105		49,50€



53385 19,30€

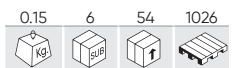

ALICATE PARA EXTRAÇÃO DE GRAMPAS DE CARROCERIA

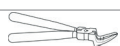

170mm



27mm

53976 9,70€

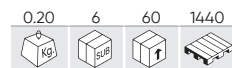

ALICATE MULTIFUNÇÃOAL DE ÂNGULO RETO 6" 160MM

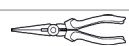

6"

160mm



50mm

16111

21,50€

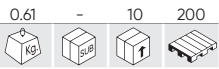

MÓDULO EVA PARA DECAPAR CABOS E TERMINAIS

	220mm
	BV1.25
	RV2-4
	SV-2-4
	MDD2-250
	BV2
	RV2-4L
	SV5.5-6
	FDD2-250



52761

8,00€

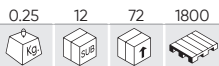

ALICATE PARA TERMINAIS ISOLADOS E NÃO ISOLADOS 9"



53932

8,00€

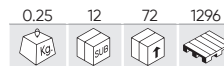

ALICATE PARA TERMINAIS PRÉ-ISOLADOS E NÃO ISOLADOS 9"



52762

9,00€

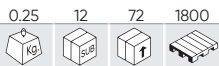

ALICATE PARA TERMINAIS NÃO ISOLADOS 8-3/4"



54702

9,00€

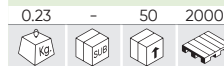

NEW

ALICATE DESCASCADOR E CRIMPADOR DE TERMINAIS 10"

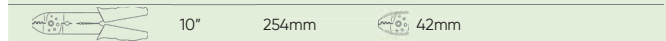
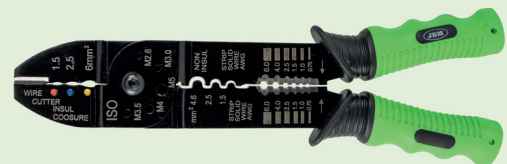

54254

43,00€

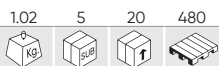

ALICATE DE TERMINAIS COM PONTA INTERCAMBIÁVEL

	9"
	PH2x100
	0,15-6mm ²
	10-35mm ²
	0,5-6mm ²
	0,5-10mm ²
	0,5-4mm ²



54112

18,00€

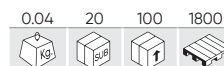

EXTRATOR DE TERMINAIS COM SEIS CONECTORES

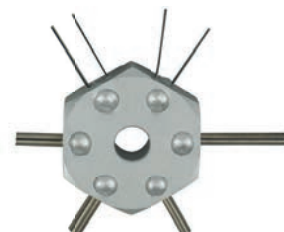

54142 15,20€

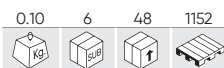

CONJUNTO DE GANCHO, PICARETA E PÉ DE CABRA (6 PCS)



- x2 Pontas de gancho
- x2 Pontas anguladas
- x2 Pontas retas
- x6 Pontas com alavancas

51525 9,80€

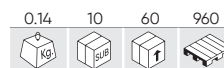

PESCA PEÇAS FLEXÍVEL COM PONTA MAGNÉTICA

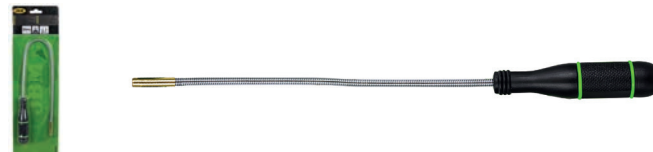

- 500mm
- Ø 7mm

51526 9,80€



PESCA PEÇAS FLEXÍVEL COM PONTA DE 4 GARRAS



- 500mm
- Ø 35mm

52473 9,90€



PESCA PEÇAS MAGNETICO COM LED NA PONTA

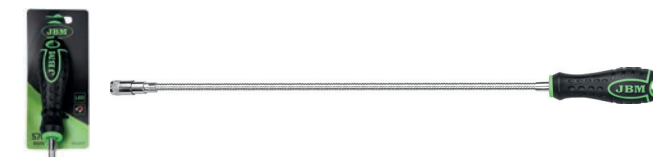

- 545mm
- Ø 15mm

51272 7,50€

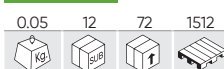

PESCA PEÇAS MAGNÉTICO COM PONTA DE LED



EM EXPOSITOR DE 12 UDS

- 90-810mm
- Ø 18mm

52472 4,90€



PESCA PEÇAS MAGNÉTICO EXTENSÍVEL



- 135-600mm
- Ø 10mm

52468 5,90€

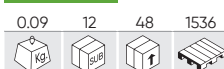

ESPELHO TELESCÓPICO ARTICULADO



- 280-445mm
- Ø 50mm

15706 32,00€



MÓDULO DE GRIP MAGNÉTICO - 5 PEÇAS



MARTELO EN CUNHA

REF.	g	mm					€
51674	505g	330mm	0.60	6	36	864	8,10€
52565	1000g	365mm	1.13	6	24	720	11,50€



MARTELO FORMA DE BOLA

REF.	g	mm					€
51504	454g	320mm	0.55	4	40	800	9,30€
51918	1000g	360mm	1.25	6	18	864	12,50€



MACHADO COM CABO DE MADEIRA

REF.	mm					€
52460	410mm	1.17	4	24	864	17,80€



MARTELO PROFISSIONAIS ANTI-RETROCESSO

REF.	Kg	mm					€
52180	1,35Kg	355mm	1.45	6	12	432	19,00€
52181	1,80Kg	370mm	1.81	6	12	300	22,50€
52183	2,20Kg	405mm	2.30	6	12	288	26,20€



MARTELO NYLON

REF.	ø	mm					€
14303	35mm	350mm	3.95	-	50	-	12,00€



MARTELO NYLON ANTI-RETROCESSO

REF.	ø	mm					€
52425	40mm	310mm	0.70	6	12	768	36,00€
52426	60mm	420mm	1.50	2	12	288	55,00€
52427	70mm	480mm	2.02	2	12	204	68,00€



MARTELO PROFISSIONAL CON PUNHO DE FIBRA

REF.	Kg	mm					€
52182	2Kg	297mm	2.20	6	12	504	24,00€
52184	4Kg	880mm	4.31	-	4	100	43,00€
52185	6Kg	895mm	6.97	-	4	72	60,00€
52186	8Kg	900mm	8.68	-	2	68	73,00€



NEW MAÇO PROFISSIONAL

REF.	g	mm						€
54704	1100g	260mm	1.50	6	24	1440	24,00€	



NEW MARTELO ANTI-REBOTE DE NYLON

REF.	g	mm						€
54705	608g	350mm	0.50	6	24	384	18,50€	



NEW MAÇO DE BORRACHA

REF.	g	mm						€
55010	450g	340mm	0.60	5	20	400	10,50€	



52831 18,00€

0.49	-	20	480

SERRA



REPOSIÇÕES DISPONÍVEIS



EM EXPOSITOR DE 10 UDS

	98x300mm
	12" - 300mm (24T)

54699 8,50€

0.15	12	72	2592

NEW

MINI SERRA MANUAL



	270mm
	150mm

52786 14,60€

0.16	12	60	2100

NAVALHA COM FUNÇÃO CORTA-CINTOS E PONTEIRA QUEBRA-VIDROS

	200mm
	80mm



EM EXPOSITOR DE 12 UDS

54505 31,00€

0.70	-	20	360

CONJUNTO DE FACAS E RASPADORES

	x5	12mm		x5	19mm		x1	160mm
	x5	16mm		x5	20mm		x1	150mm
	x5	16mm						

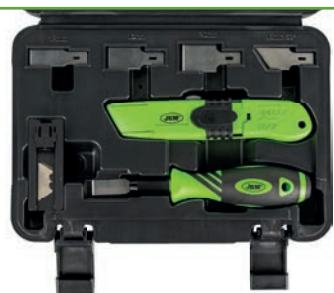

REPOSIÇÕES DISPONÍVEIS

52877

16,70€

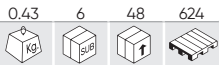

TESOURA CORTA TUBOS 42MM



53517

9,50€

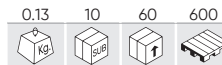

TESOURA CORTA-TUBOS 30 MM



52878

11,20€

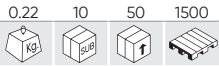

CORTA TUBOS 3-32MM



52879

10,70€

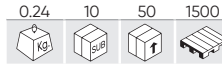

CORTA TUBOS 3-35MM



52885

18,80€

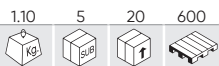

KT DE 12 VAZADORES - METRICO

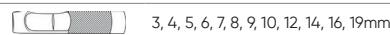

51909

2,50€

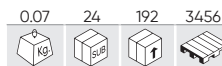

CORTADOR PROFSSIONAL



REPOSIÇÕES DISPONÍVEIS



EM EXPOSITOR DE 24 UDS

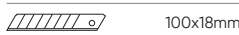

54331

29,50€

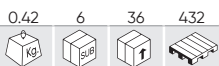

CONJUNTO DE 3 CORTADORES PROFISSIONAIS

	LÂMINA	TAMANHO LÂMINA	COMPRIMENTO
A	x4	60x19mm	175mm
B	x1	100x10mm	160mm
C	x4	60x19mm	175mm



REPOSIÇÕES DISPONÍVEIS

54703

11,50€

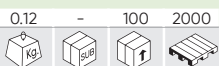

NEW

PUNZÃO DE CENTRO AUTOMÁTICO



ESCOPRO

REF.	mm						€
53120	150mm	0.35	6	24	1200		6,00€
53121	250mm	0.55	6	24	864		8,50€
53122	350mm	0.90	6	12	720		9,50€



53083 64,00€

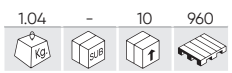

KIT DE 4 CINZÉIS



18x125, 21x150, 26x200, 29x250mm

54089 19,60€

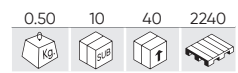

KIT DE 5 CINZÉIS



REPOSIÇÕES DISPONÍVEIS

10x155, 11x155, 12x155, 14x155, 16x155mm

15737 48,50€

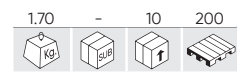

MÓDULO DE CINZÉIS E PONTEIROS

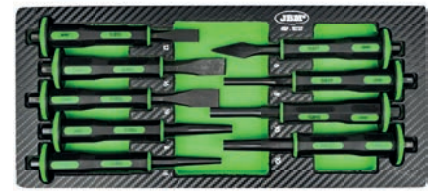

53095 20,50€

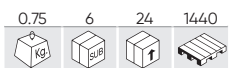

KIT DE 6 PONTEIROS



3, 4, 5, 6, 7, 8mm

54099 14,70€

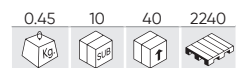

KIT DE 5 PONTEIROS



4, 5, 6, 7, 8mm

52049 14,00€

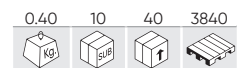

KIT DE 5 PUNÇÕES CÔNICOS



3, 4, 5, 6, 7mm

53993 85,00€

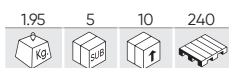

REBITADEIRA ARTICULADA MULTIFUNCCIONAL



A	x1	360°	D	x4	3/32", 1/8", 5/32", 3/16"
B	x4	M3x0.5, M4x0.7, M5x0.8, M6x1	E	x3	M4x0.7, M5x0.8, M6x1
C	x4	M3x0.5, M4x0.7, M5x0.8, M6x1	F	x3	5.5x8.5, 12x17, 15x19mm

54585 87,00€



REBITADEIRA ARTICULADA MULTIFUNÇÕES



VÍDEO TUTORIAL

A	x1	275mm - 360°
B	x4	M3, M4, M5, M6
C	x2	Adaptadores

52595

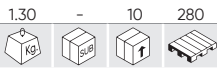

REBITADEIRA COMPACTO 200MM / 8"

	8" - 200mm
	M3, M4, M5, M6



66,00€

52462

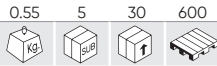

REBITADEIRA COMPACTO 200MM / 8"

	8" - 200mm
	2.4mm (3/32"), 3.2mm (1/8"), 4.0mm (5/32"), 4.8mm (3/16")



25,30€

52597



ALICATE DE REBITAR AUTOMATICO 440MM / 17"

	17" - 440mm
	M3, M4, M5, M6, M8, M10, M12



146,00€

52596

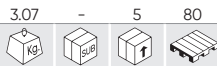

REBITADEIRA DE PORCA 400MM/16"

	16" - 400mm
	M3, M4, M5, M6, M8, M10, M12



114,00€

52463

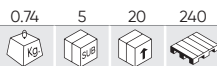

REBITADEIRA 300MM / 12"

	12" - 300mm
	3.2mm (1/8"), 4.0mm (5/32"), 4.8mm (3/16")



28,50€

52464

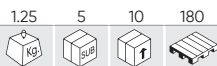

REBITADEIRA 400MM/16"

	16" - 400mm
	2.4mm (3/32"), 3.2mm (1/8"), 4.0mm (5/32"), 4.8mm (3/16"), 6.4mm (1/4")



42,00€

13667

24,00€

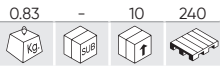

MÓDULO EVA DE REBITADEIRA E REBITES



PEÇA DE REPOSIÇÃO PARA 52595, 52596, 52597

REF.							€
13226		M3	0.03	-	100	14999	6,40€
13227		M4	0.04	-	100	-	6,40€
13228		M5	0.04	20	100	-	6,40€
13229		M6	0.04	20	100	-	6,40€

REF.							€
13230		M8	0.04	-	200	-	6,40€
13231		M10	0.05	-	100	-	6,40€
13232		M12	0.05	-	100	-	6,40€



53331

34,00€

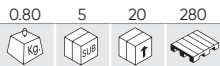

REBITADEIRA DE EMPURRAR 10" 250MM



	10" - 250mm
	2.4mm (3/32"), 3.2mm (1/8"), 4.0mm (5/32"), 4.8mm (3/16"), 6.4mm (1/4")

53332

37,00€

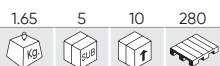

REBITADEIRA EXTENSÍVEL 8" 200MM



	8" - 200mm
	2.4mm (3/32"), 3.2mm (1/8"), 4.0mm (5/32"), 4.8mm (3/16"), 6.4mm (1/4")

52609

29,00€

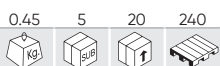

REBITADEIRA + CAIXA DE REBITES PLÁSTICOS



REPOSIÇÕES DISPONÍVEIS

Ø 6.6x17.2, 6.3x25.2, 5x17.2, 5x15.8mm

119,00€

52575

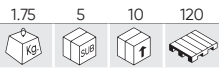

REBITADOR PNEUMÁTICO

Entrada de ar	1/4"
Adaptadores	3/16", 5/32", 1/8", 3/32"
Consumo real de ar	0,03CFM (0,86L/min)
Tração	720,00Kg
Binário máximo	23-69Nm
Peso	1,75Kg
Dimensões (CxLxA)	85x175x280mm



REPOSIÇÕES
DISPONÍVEIS



CINTA MÉTRICA

REF.	m	mm					€
53025	3m	16mm	0.13	12	48	2016	3,50€
53026	5m	22mm	0.26	12	48	3024	5,80€
53027	7.5m	25mm	0.40	12	48	1500	9,00€



EM EXPOSITOR
DE 12 UDS

NÍVEL DE ALUMÍNIO

REF.	mm					€
53613	500mm	0.55	5	30	1260	20,50€
53614	600mm	0.60	5	30	840	23,50€
53615	800mm	0.85	5	20	600	37,00€



REPOSIÇÕES
DISPONÍVEIS

NÍVEL TUBULAR MAGNETIZADO

REF.	mm					€
53616	500mm	0.30	5	60	1260	10,60€
53617	600mm	0.30	5	60	840	11,10€
53618	800mm	0.35	5	30	600	15,10€



REPOSIÇÕES
DISPONÍVEIS

54700

3,00€



NEW

RÉGUA DE AÇO INOXIDÁVEL DE 30 CM



54701

6,50€



NEW

TRANSFERIDOR DE AÇO INOXIDÁVEL



52433

4,80€

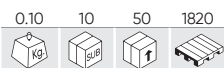

APALPA FOLGAS, -20 (0.05-1.0MM)



0.05-1.0mm

52638

10,70€

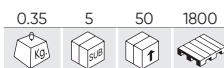

ALICATE PERFORADORA ROTATIVA



Ø 2, 2.5, 3, 3.5, 4, 4.5mm

52904

61,00€

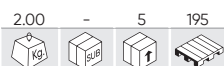

CALIBRE DE PROFUNDIDADE COM SUPORTE MAGNÉTICO



REPOSIÇÕES DISPONÍVEIS

0-10mm



PÉ DE REI

REF.	mm						€
50724	150mm	Digital	0.30	10	50	1200	28,00€
50937	150mm	Mecanico	0.24	10	50	1500	10,50€



50724



50937

CALIBRE DE PROFUNDIDADE

REF.	mm						€
52873	0-40mm	Mecanico	0.04	5	300	1500	11,60€
53042	0-25,4mm	Digital	0.05	10	100	2000	9,90€



52873



53042

GONIOMETRO

REF.	"						€
52583	1/2"	Não magnetizado	0.20	4	48	576	8,50€
52794	1/2"	Magnético	0.48	6	24	288	28,00€



52583



52794

51951

15,60€

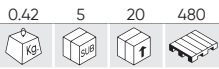

KIT DE 3 ESPÁTULAS DE AÇO



39, 65, 75mm

53339

9,50€

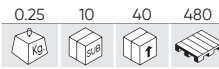

KIT DE 4 ESPÁTULAS DE AÇO



2, 3, 4, 6"

53589

15,00€

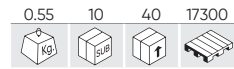

GRAMPEADOR INDUSTRIAL 3 EM 1



4-14mm/10-12mm/10-14mm

52700

20,50€

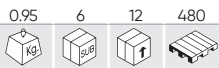

KIT DE ABOCARDADO DE TUBOS

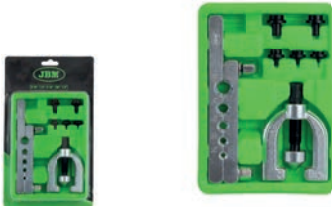

3/16, 1/4, 5/16, 3/8, 1/2"

51853

18,00€

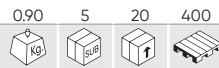

KIT DE 5 LIMAS DE AÇO



8" - 310mm

52905

28,00€



CURVA TUBOS 6-8-10MM



270mm 6, 8, 10mm

52760

4,10€

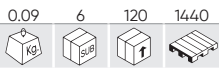

CEPILLO METÁLICO



290mm

Aço

52515

9,10€

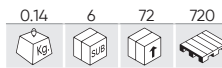

KIT DE 3 ESCOVAS METÁLICAS



225mm

Latão, nylon e aço

51989

49,50€

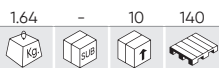

KIT 38 ESCOVAS DE LIMPEZA METAL / PLÁSTICO

A	x1	
B	x1	1/4"
C	x12	8, 9, 10, 11, 12, 13, 14, 15, 16, 17, 18, 19mm
D	x12	8, 9, 10, 11, 12, 13, 14, 15, 16, 17, 18, 19mm
E	x12	8, 9, 10, 11, 12, 13, 14, 15, 16, 17, 18, 19mm

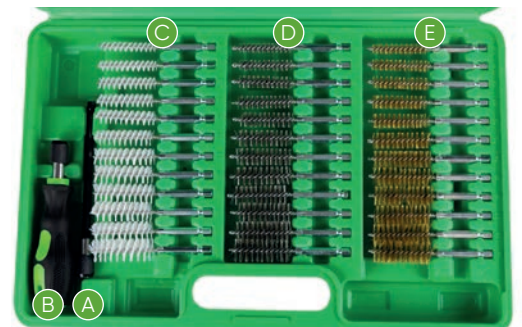

MOBILIÁRIO E EQUIPAMENTO PARA OFICINA

76	CONJUNTO DE MOBILIÁRIO
77	SÉRIES
79	MÓVEIS
83	PLACAS
83	PAINÉIS
84	CARRINHOS DE FERRAMENTAS
103	MÓDULOS DE FERRAMENTAS
113	MESAS DE TRABALHO
115	ACESSÓRIOS DE MOBILIÁRIO
119	COMPLEMENTOS AUXILIARES
119	BANCOS
120	MACAS
121	SACOS
122	CAIXAS
124	TORNO DE BANCADA
124	OUTROS
127	PAVIMENTAÇÃO





Nova gama de mobiliário para oficina

Sistema modular

Crie o seu ambiente de trabalho a partir do zero, adaptando-o ao seu espaço e às suas necessidades com múltiplas combinações do nosso mobiliário



A cor da sua marca, agora no seu carro de ferramentas

Pode personalizar o seu conjunto de forma rápida e simples para combinar com as cores corporativas da sua oficina. Um método de personalização prático que o ajuda a manter a imagem profissional e coerente do seu espaço de trabalho.

Se já tem os nossos conjuntos de móveis,

Não se preocupe – temos conjuntos de puxadores preparados para cada SÉRIE, bem como para cada módulo individual. Só precisa escolher a cor que mais gosta e indicar-nos a referência, para que possamos preparar a sua encomenda. Assim, poderá personalizar o produto e adaptá-lo à estética da sua oficina, mantendo uma identidade visual coerente.

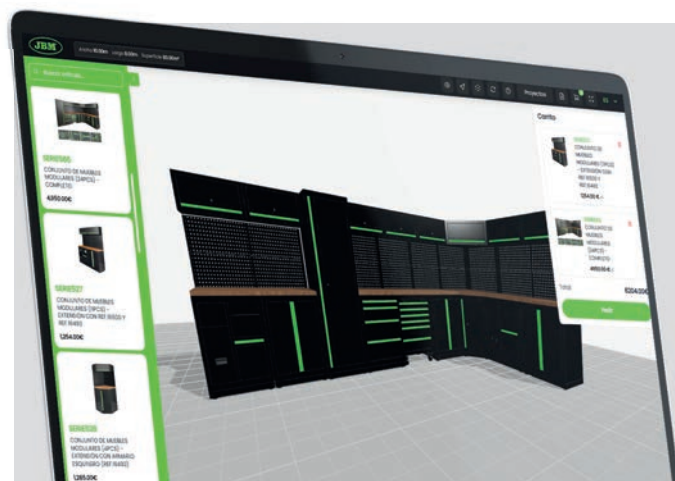

Configurador JBM



Na JBM, oferecemos uma plataforma web que permite projetar e personalizar o seu mobiliário através de um modelo 3D completo com visualização em tempo real. À medida que

configura cada elemento, o sistema gera automaticamente o render integral do espaço com todos os móveis selecionados e uma lista detalhada dos produtos necessários para a sua construção. Como resultado, obtém um orçamento preciso, atualizado e totalmente alinhado com o seu projeto.

SERIE565 4.950,00€

584.70 - - -

NEW

SERIE587 5.645,00€

661.70 - - -

NEW

SERIE565



REPOSIÇÕES DISPONÍVEIS



SERIE587



REPOSIÇÕES DISPONÍVEIS

SERIE565

CONJUNTO DE MÓVEIS EM CORES

REF.	€	REF.	€
SERIE565R	5.120,00€	SERIE565G	5.120,00€
SERIE565B	5.120,00€	SERIE565P	5.120,00€
SERIE565Y	5.120,00€	SERIE565K	5.120,00€
SERIE565O	5.120,00€	SERIE565S	5.120,00€

JOGO DE PUXADORES

REF.	€	REF.	€
18037	209,00€	18041	209,00€
18038	209,00€	18042	209,00€
18039	209,00€	18043	209,00€
18040	209,00€	18044	209,00€

SERIE587

CONJUNTO DE MÓVEIS EM CORES

REF.	€	REF.	€
SERIE587R	5.815,00€	SERIE587G	5.815,00€
SERIE587B	5.815,00€	SERIE587P	5.815,00€
SERIE587Y	5.815,00€	SERIE587K	5.815,00€
SERIE587O	5.815,00€	SERIE587S	5.815,00€

CONTÉM:

53708 325,00€



KIT DE 4 MÓDULOS DE CARBONO EVA PARA FERRAMENTAS

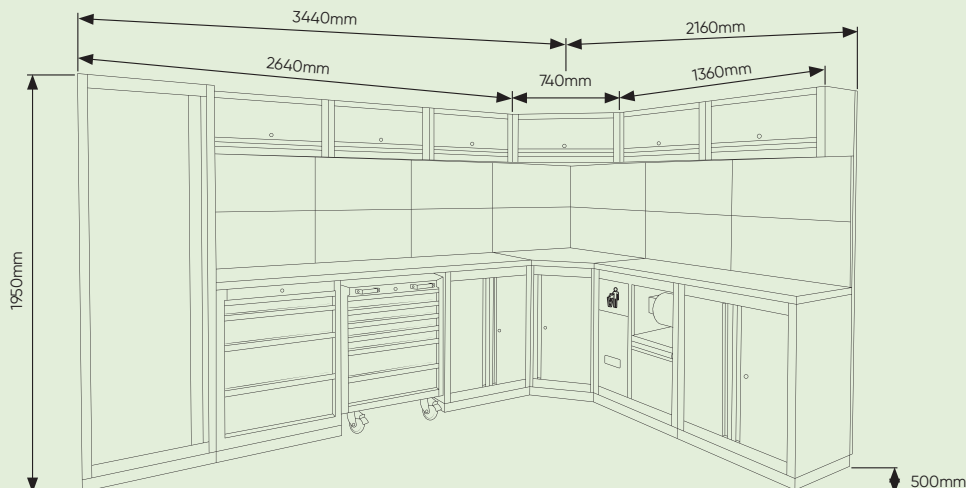
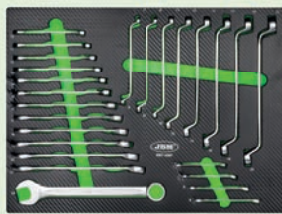
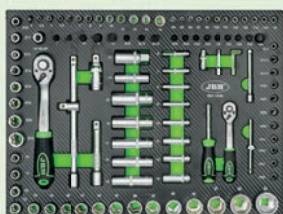

SERIE446

2.350,00€

SERIE588

2.598,00€

318.00 - - -

NEW

351.20 - - -

NEW

SERIE446



REPOSIÇÕES DISPONÍVEIS

SERIE588



REPOSIÇÕES DISPONÍVEIS



SERIE446

CONJUNTO DE MÓVEIS EM CORES

REF.	€	REF.	€
SERIE446R	2.393,00€	SERIE446G	2.393,00€
SERIE446B	2.393,00€	SERIE446P	2.393,00€
SERIE446Y	2.393,00€	SERIE446K	2.393,00€
SERIE446O	2.393,00€	SERIE446S	2.393,00€

JOGO DE PUXADORES

REF.	€	REF.	€
17849	154,00€	17853	154,00€
17850	154,00€	17854	154,00€
17851	154,00€	17954	154,00€
17852	154,00€	17955	154,00€

SERIE588

CONJUNTO DE MÓVEIS EM CORES

REF.	€	REF.	€
SERIE588R	2.631,00€	SERIE588G	2.631,00€
SERIE588B	2.631,00€	SERIE588P	2.631,00€
SERIE588Y	2.631,00€	SERIE588K	2.631,00€
SERIE588O	2.631,00€	SERIE588S	2.631,00€

CONTÉM:

53708

325,00€

15.20 - 1 20

KIT DE 4 MÓDULOS DE CARBONO EVA PARA FERRAMENTAS

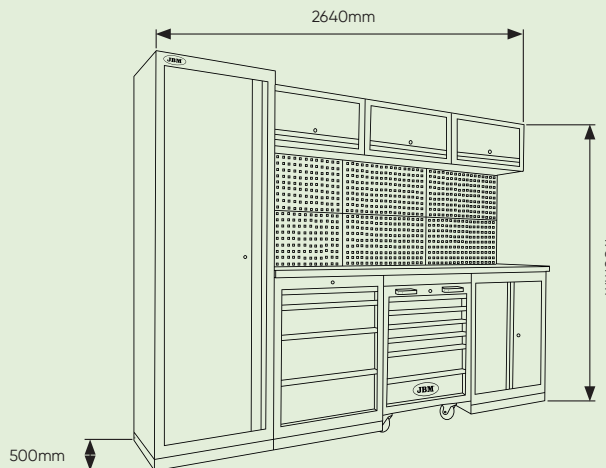
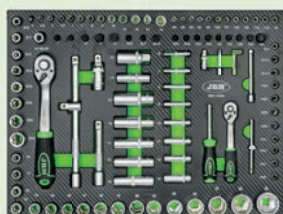



16500

463,00€

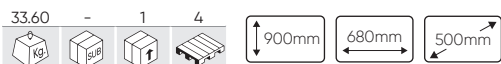

ARMÁRIO COM 2 PORTAS

MÓVEL EM CORES

REF.						€
16500R		33.95	-	1	4	470,00€
16500B		33.95	-	1	4	470,00€
16500Y		33.95	-	1	4	470,00€
16500O		33.95	-	1	4	470,00€
16500G		33.95	-	1	4	470,00€
16500P		33.95	-	1	4	470,00€
16500K		33.95	-	1	4	470,00€
16500S		33.95	-	1	4	470,00€

JOGO DE PUXADORES

REF.						€
17797		0.36	-	25	625	17,75€
17798		0.36	-	25	625	17,75€
17799		0.36	-	25	625	17,75€
17800		0.36	-	25	625	17,75€
17801		0.36	-	25	625	17,75€
17802		0.36	-	25	625	17,75€
17958		0.36	-	25	625	17,75€
17959		0.36	-	25	625	17,75€



REPOSIÇÕES DISPONÍVEIS

16627

537,00€



ARMÁRIO COM 4 GAVETAS

MÓVEL EM CORES

REF.						€
16627R		44.94	-	1	4	547,00€
16627B		44.94	-	1	4	547,00€
16627Y		44.94	-	1	4	547,00€
16627O		44.94	-	1	4	547,00€
16627G		44.94	-	1	4	547,00€
16627P		44.94	-	1	4	547,00€
16627K		44.94	-	1	4	547,00€
16627S		44.94	-	1	4	547,00€

JOGO DE PUXADORES

REF.						€
17803		0.44	-	25	375	31,00€
17804		0.44	-	25	375	31,00€
17805		0.44	-	25	375	31,00€
17806		0.44	-	25	375	31,00€
17807		0.44	-	25	375	31,00€
17808		0.44	-	25	375	31,00€
17962		0.44	-	25	375	31,00€
17963		0.44	-	25	375	31,00€



REPOSIÇÕES DISPONÍVEIS

16628

594,00€



ARMÁRIO DE 6 GAVETAS

MÓVEL EM CORES

REF.					€
16628R	●	49.63	-	1 4	607,00€
16628B	●	49.63	-	1 4	607,00€
16628Y	●	49.63	-	1 4	607,00€
16628O	●	49.63	-	1 4	607,00€
16628G	●	49.63	-	1 4	607,00€
16628P	●	49.63	-	1 4	607,00€
16628K	●	49.63	-	1 4	607,00€
16628S	●	49.63	-	1 4	607,00€

JOGO DE PUXADORES

REF.					€
17809	●	0.63	-	25 250	49,25€
17810	●	0.63	-	25 250	49,25€
17811	●	0.63	-	25 250	49,25€
17812	●	0.63	-	25 250	49,25€
17813	●	0.63	-	25 250	49,25€
17814	●	0.63	-	25 250	49,25€
17964	●	0.63	-	25 250	49,25€
17965	●	0.63	-	25 250	49,25€



REPOSIÇÕES DISPONÍVEIS

16493

463,00€

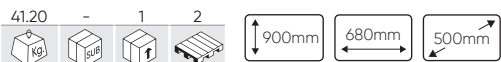

ARMÁRIO COM 3 GAVETAS E SUPORTE PARA ROLO DE PAPEL

MÓVEL EM CORES

REF.					€
16493R	●	41.31	-	1 2	466,00€
16493B	●	41.31	-	1 2	466,00€
16493Y	●	41.31	-	1 2	466,00€
16493O	●	41.31	-	1 2	466,00€
16493G	●	41.31	-	1 2	466,00€
16493P	●	41.31	-	1 2	466,00€
16493K	●	41.31	-	1 2	466,00€
16493S	●	41.31	-	1 2	466,00€

JOGO DE PUXADORES

REF.					€
17815	●	0.11	-	25 1250	9,00€
17816	●	0.11	-	25 1250	9,00€
17817	●	0.11	-	25 1250	9,00€
17818	●	0.11	-	25 1250	9,00€
17819	●	0.11	-	25 1250	9,00€
17820	●	0.11	-	25 1250	9,00€
17974	●	0.11	-	25 1250	9,00€
17975	●	0.11	-	25 1250	9,00€



REPOSIÇÕES DISPONÍVEIS

16492

675,00€

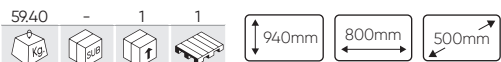

ARMÁRIO DE CANTO COM CHAPA DE MDF

MÓVEL EM CORES

REF.					€
16492R	●	59.65	-	1 1	678,00€
16492B	●	59.65	-	1 1	678,00€
16492Y	●	59.65	-	1 1	678,00€
16492O	●	59.65	-	1 1	678,00€
16492G	●	59.65	-	1 1	678,00€
16492P	●	59.65	-	1 1	678,00€
16492K	●	59.65	-	1 1	678,00€
16492S	●	59.65	-	1 1	678,00€

JOGO DE PUXADORES

REF.					€
17821	●	0.25	-	25 625	10,50€
17822	●	0.25	-	25 625	10,50€
17823	●	0.25	-	25 625	10,50€
17824	●	0.25	-	25 625	10,50€
17825	●	0.25	-	25 625	10,50€
17826	●	0.25	-	25 625	10,50€
17966	●	0.25	-	25 625	10,50€
17967	●	0.25	-	25 625	10,50€



REPOSIÇÕES DISPONÍVEIS

18103 789,00€

38.00 - 1 4  949mm 680mm 500mm **NEW**

ARMÁRIO COM PIA INTEGRADA

MÓVEL EM CORES

REF.						€
18103R		38.35	-	1	4	840,00€
18103B		38.35	-	1	4	840,00€
18103Y		38.35	-	1	4	840,00€
18103O		38.35	-	1	4	840,00€
18103G		38.35	-	1	4	840,00€
18103P		38.35	-	1	4	840,00€
18103K		38.35	-	1	4	840,00€
18103S		38.35	-	1	4	840,00€

JOGO DE PUXADORES

REF.						€
18189		0.36	-	25	625	19,50€
18190		0.36	-	25	625	19,50€
18191		0.36	-	25	625	19,50€
18192		0.36	-	25	625	19,50€
18193		0.36	-	25	625	19,50€
18194		0.36	-	25	625	19,50€
18195		0.36	-	25	625	19,50€
18196		0.36	-	25	625	19,50€



REPOSIÇÕES DISPONÍVEIS

18105 1.148,00€

102.20 - 1 1  1950mm 1050mm 620mm **NEW**

ARMÁRIO ALTO DE DUAS PORTAS

MÓVEL EM CORES

REF.						€
18105R		85.60	-	1	1	1.186,00€
18105B		85.60	-	1	1	1.186,00€
18105Y		85.60	-	1	1	1.186,00€
18105O		85.60	-	1	1	1.186,00€
18105G		85.60	-	1	1	1.186,00€
18105P		85.60	-	1	1	1.186,00€
18105K		85.60	-	1	1	1.186,00€
18105S		85.60	-	1	1	1.186,00€

JOGO DE PUXADORES

REF.						€
18179		1.10	-	25	100	38,00€
18180		1.10	-	25	100	38,00€
18181		1.10	-	25	100	38,00€
18182		1.10	-	25	100	38,00€
18183		1.10	-	25	100	38,00€
18184		1.10	-	25	100	38,00€
18185		1.10	-	25	100	38,00€
18186		1.10	-	25	100	38,00€



REPOSIÇÕES DISPONÍVEIS

16490 650,00€

56.20 - 1 6  1890mm 600mm 500mm

ARMÁRIO ALTO

MÓVEL EM CORES

REF.						€
16490R		56.75	-	1	6	660,00€
16490B		56.75	-	1	6	660,00€
16490Y		56.75	-	1	6	660,00€
16490O		56.75	-	1	6	660,00€
16490G		56.75	-	1	6	660,00€
16490P		56.75	-	1	6	660,00€
16490K		56.75	-	1	6	660,00€
16490S		56.75	-	1	6	660,00€

JOGO DE PUXADORES

REF.						€
17827		0.59	-	25	-	34,50€
17828		0.59	-	25	-	34,50€
17829		0.59	-	25	-	34,50€
17830		0.59	-	25	-	34,50€
17831		0.59	-	25	-	34,50€
17832		0.59	-	25	-	34,50€
17968		0.59	-	25	-	34,50€
17969		0.59	-	25	-	34,50€



REPOSIÇÕES DISPONÍVEIS



16494

149,00€



ARMÁRIO DE PAREDE

MÓVEL EM CORES

REF.		kg	Box	Box	Box	Box	€
16494R	●	10.60	-	1	9	143,00€	
16494B	●	10.60	-	1	9	143,00€	
16494Y	●	10.60	-	1	9	143,00€	
16494O	●	10.60	-	1	9	143,00€	
16494G	●	10.60	-	1	9	143,00€	
16494P	●	10.60	-	1	9	143,00€	
16494K	●	10.60	-	1	9	143,00€	
16494S	●	10.60	-	1	9	143,00€	

JOGO DE PUXADORES

REF.		kg	Box	Box	Box	Box	€
17833	●	0.20	-	25	625	10,50€	
17834	●	0.20	-	25	625	10,50€	
17835	●	0.20	-	25	625	10,50€	
17836	●	0.20	-	25	625	10,50€	
17837	●	0.20	-	25	625	10,50€	
17838	●	0.20	-	25	625	10,50€	
17972	●	0.20	-	25	625	10,50€	
17973	●	0.20	-	25	625	10,50€	



REPOSIÇÕES DISPONÍVEIS

16491

298,00€



ARMÁRIO DE PAREDE DE CANTO

MÓVEL EM CORES

REF.		kg	Box	Box	Box	Box	€
16491R	●	22.20	-	1	4	299,00€	
16491B	●	22.20	-	1	4	299,00€	
16491Y	●	22.20	-	1	4	299,00€	
16491O	●	22.20	-	1	4	299,00€	
16491G	●	22.20	-	1	4	299,00€	
16491P	●	22.20	-	1	4	299,00€	
16491K	●	22.20	-	1	4	299,00€	
16491S	●	22.20	-	1	4	299,00€	

JOGO DE PUXADORES

REF.		kg	Box	Box	Box	Box	€
17839	●	0.22	-	25	625	11,00€	
17840	●	0.22	-	25	625	11,00€	
17841	●	0.22	-	25	625	11,00€	
17842	●	0.22	-	25	625	11,00€	
17843	●	0.22	-	25	625	11,00€	
17844	●	0.22	-	25	625	11,00€	
17970	●	0.22	-	25	625	11,00€	
17971	●	0.22	-	25	625	11,00€	



REPOSIÇÕES DISPONÍVEIS

NEW PLACAS									
REF.	DIMENSÕES	MATERIAL							€
16497	680x500x40mm	Madeira	Projetado para cobrir 1 módulo	9,80	-	1	22	77,00€	
16496	1360x500x40mm	Madeira	Projetado para cobrir 2 módulos	18,45	-	1	19	127,00€	
16629	2040x500x40mm	Madeira	Projetado para cobrir 3 módulos	27,80	-	1	20	185,00€	
17746	680x500x40mm	Aço inoxidável	Projetado para cobrir 1 módulo	12,00	-	1	24	186,00€	
17747	1360x500x40mm	Aço inoxidável	Projetado para cobrir 2 módulos	24,00	-	1	20	251,00€	
16600	2040x500x40mm	Aço inoxidável	Projetado para cobrir 3 módulos	33,60	-	1	20	252,00€	

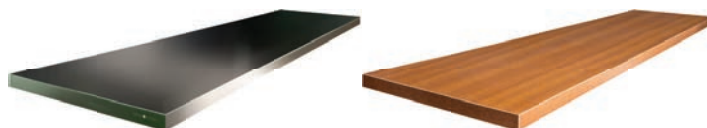

PAINEL DE CANTO

REF.	DIMENSÕES	MATERIAL						€
16835	800x500x425x40mm	Madeira	Projetado para cobrir 1 módulo	16,60	-	1	-	158,00€
16836	800x500x425x40mm	Aço inoxidável	Projetado para cobrir 1 módulo	20,00	-	1	-	248,00€



PANEL DE FERRAMENTAS

REF.	PEÇAS	DIMENSÕES						€
16498	x1	680x340x25mm		2,00	2	6	180	26,00€
16516	x4	775x340x25mm (x2) + 800x340x25mm (x2)		2,30	-	1	16	121,00€

ACOPLAMENTO QUADRADO



OUTROS

REF.	DIMENSÕES	DESCRIÇÃO						€
16561	1890x60x25mm	BARRA DE SUPORTE (REF.54327)		2,20	-	10	200	36,50€



17919 40,50€

0.66 10 20 600

NEW

CONJUNTO DE 3 LUZES LED MAGNÉTICAS COM INTERRUPTOR PARA CONJUNTOS MODULARES

17921 12,50€

0.16 10 50 20000

NEW

FITA DE LED SIMPLES SEM INTERRUPTOR PARA REF. 17919



53868

1.090,00€

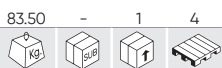

CARRINHO DE FERRAMENTAS COM 12 GAVETAS - VERDE - VAZIAS

Material	Acero/Steel, ABS
Gavetas	12
Dimensões da gaveta	533x400x75mm
Medidas de gaveta média	533x400x154mm
Dimensões gaveta grande	533x400x233mm
Capacidade da gaveta pequena	35Kg

53939

1.280,00€

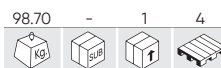

CARRINHO DE FERRAMENTAS COM 12 GAVETAS - VERDE - MONTADO

Capacidade da gaveta média	35Kg
Capacidade da gaveta grande	35Kg
Capacidade de carga do tabeieiro superior	40Kg
Capacidade	300Kg
Peso	83,50Kg
Dimensões (CxLxA)	1005x460x990mm

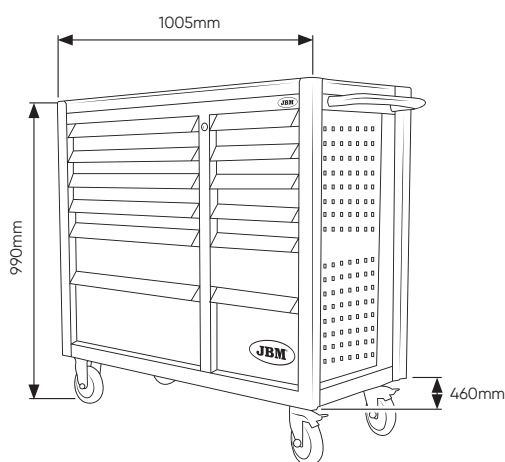

53868



REPOSIÇÕES DISPONÍVEIS

53939



REPOSIÇÕES DISPONÍVEIS

ACOPLAMENTO QUADRADO

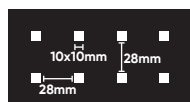

O CARRO COM DOTAÇÃO CONTÉM:

53708

325,00€

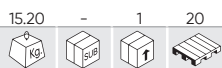

KIT DE 4 MÓDULOS DE CARBONO EVA PARA FERRAMENTAS

14296

122,00€



14297

93,00€

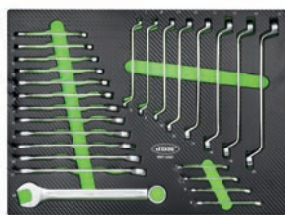

14298

55,00€

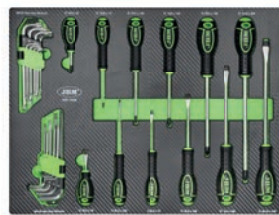

14299

93,00€



54511 1.097,00€

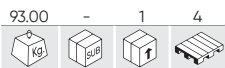

CARRO DE FERRAMENTAS COM 11 GAVETAS – VAZIO

Material	Acero/Steel
Gavetas	11
Medidas da gaveta pequena	569x400x75mm
Dimensões gaveta grande	569x400x233mm
Medidas da gaveta alongada	933x400x138mm
Capacidade da gaveta pequena	30Kg

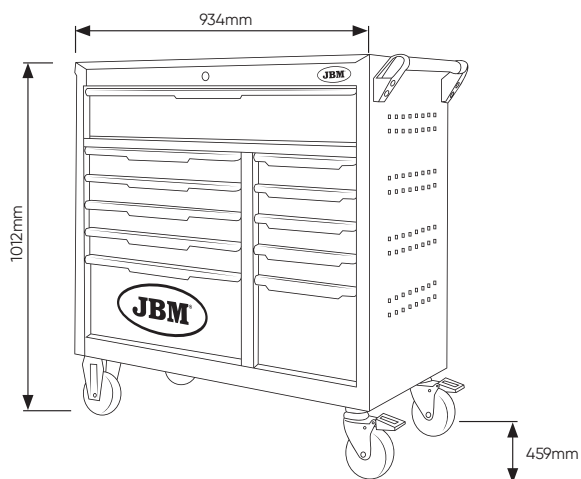

54725 2.330,00€

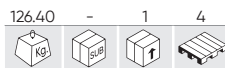

CARRINHO DE FERRAMENTAS 11 GAVETAS – MONTADO

Capacidade da gaveta grande	30Kg
Capacidade da gaveta alongada	40Kg
Capacidade de carga do tableiro superior	130Kg
Capacidade	400Kg
Peso	93,00Kg
Dimensões (CxLxA)	934x459x1012mm



REPOSIÇÕES DISPONÍVEIS



REPOSIÇÕES DISPONÍVEIS

ACOPLAMENTO QUADRADO

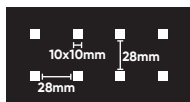

O CARRO COM DOTAÇÃO CONTÉM:

17729 445,00€



17141 369,00€



17142 222,00€



17144 385,00€



54509

1.890,00€

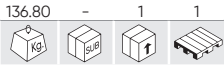

CARRINHO DE FERRAMENTAS COM 7 GAVETAS FRONTAIS E 4 GAVETAS LATERAIS – VAZIO

Material	Acero/Steel
Gavetas	11
Medidas da gaveta pequena	569x400x75mm
Dimensões gaveta grande	569x400x154mm
Capacidade da gaveta pequena	35Kg

54723

3.390,00€

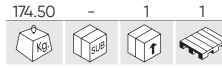

CARRINHO DE FERRAMENTAS 7 GAVETAS FRONTAIS 4 GAVETAS LATERAIS – MONTADO

Capacidade da gaveta grande	40Kg
Capacidade de carga do tabeireiro superior	150Kg
Capacidade	405Kg
Peso	136,80Kg
Dimensões (CxLxA)	1131x720x998mm

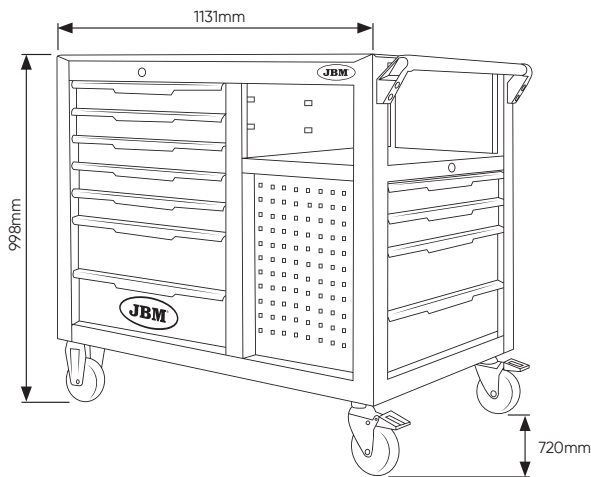

54509



REPOSIÇÕES DISPONÍVEIS

54723



REPOSIÇÕES DISPONÍVEIS

ACOPLAMENTO QUADRADO

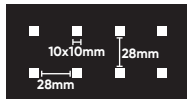

O CARRO COM DOTAÇÃO CONTÉM:

14296

122,00€



14297

93,00€



14298

55,00€



14299

93,00€



15681

143,00€

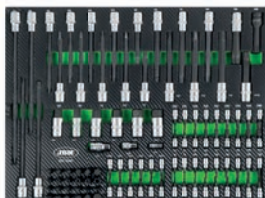

15736

489,00€



15161

62,00€

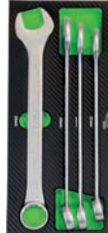

15158

63,00€



15156

70,00€



55117

1.390,00€

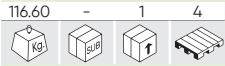

NEW

CARRO DE FERRAMENTAS 11 GAVETAS COM PAINÉIS E ARMÁRIOS – VAZIO

Peças	8
Material	Acero/Steel
Gavetas	11
Medidas da gaveta pequena	569x400x75mm
Dimensões gaveta grande	569x400x233mm
Medidas da gaveta alongada	933x400x138mm
Capacidade da gaveta pequena	30Kg

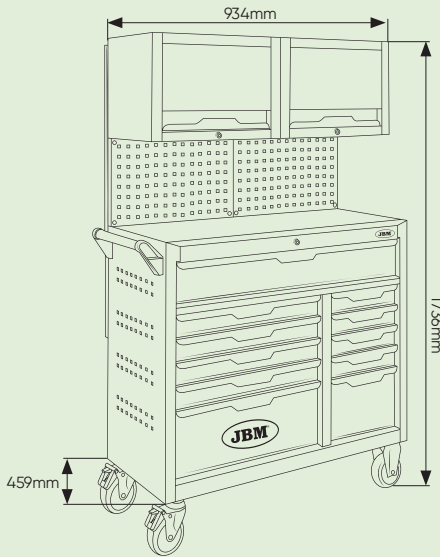

55118

1.790,00€



NEW

CARRO DE FERRAMENTAS 11 GAVETAS COM PAINÉIS E ARMÁRIOS – MONTADO

Capacidade da gaveta grande	30Kg
Capacidade da gaveta alongada	40Kg
Capacidade de carga do tabuleiro superior	130Kg
Capacidade	400Kg
Peso	116,60Kg
Dimensões (CxLxA)	934x459x1736mm



55118



REPOSIÇÕES DISPONÍVEIS

55117



REPOSIÇÕES DISPONÍVEIS



VÍDEO TUTORIAL

ACOPLAMENTO QUADRADO

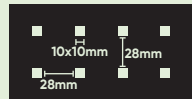

O CARRO COM DOTAÇÃO CONTÉM:

53708

325,00€

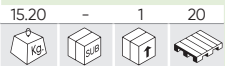

KIT DE 4 MÓDULOS DE CARBONO EVA PARA FERRAMENTAS

14296

122,00€



14297

93,00€



14298

55,00€

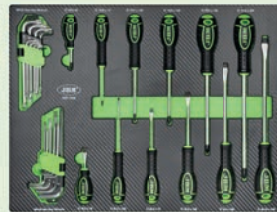

14299

93,00€



54510

1.949,50€

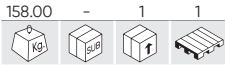

CARRINHO DE FERRAMENTAS COM 11 GAVETAS E PAINEL PERFURADO – VAZIO

Material	Acero/Steel
Gavetas	11
Medidas da gaveta pequena	480x316x70mm
Dimensões gaveta grande	480x663x70mm
Medidas da gaveta alongada	480x14350x112mm
Medidas do armário	346x556x527mm
Capacidade da gaveta pequena	30Kg

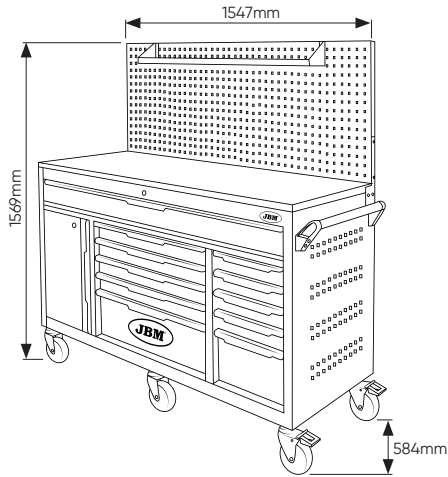

54510



REPOSIÇÕES DISPONÍVEIS

54724



REPOSIÇÕES DISPONÍVEIS

ACOPLAMENTO QUADRADO

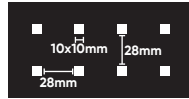

54724

3.390,00€

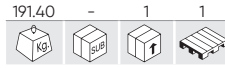

CARRINHO DE FERRAMENTAS 11 GAVETAS COM PAINEL PERFURADO - MONTADO

Capacidade da gaveta grande	30Kg
Capacidade da gaveta alongada	75Kg
Capacidade do armário	20Kg
Capacidade de carga do tableiro superior	200Kg
Capacidade	600Kg
Peso	158,00Kg
Dimensões (CxLxA)	1547x584x1569mm



O CARRO COM DOTAÇÃO CONTÉM:

17728

445,00€

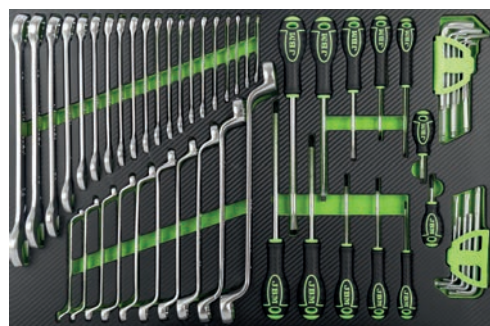

17141

369,00€



17142

222,00€



17144

385,00€



54717 549,00€

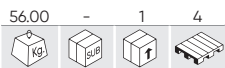

CARRINHO DE FERRAMENTAS COM 8 GAVETAS VAZIAS

Material	Acero/Steel, ABS
Gavetas	8
Medidas da gaveta pequena	575x428x75mm
Dimensões gaveta grande	575x428x150mm
Capacidade da gaveta pequena	35Kg

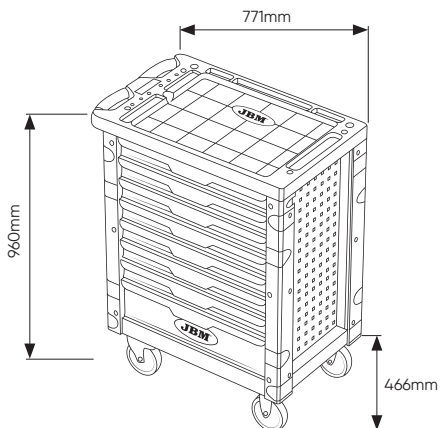

54717



REPOSIÇÕES DISPONÍVEIS

54718



REPOSIÇÕES DISPONÍVEIS

ACOPLAMENTO QUADRADO

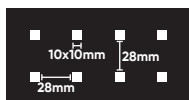

O CARRO COM DOTAÇÃO CONTÉM:

54720 1.549,00€

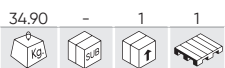

CONJUNTO DE 7 TABULEIROS PARA CARRINHO DE FERRAMENTAS

17138 245,00€



17139 130,00€



18463 167,00€

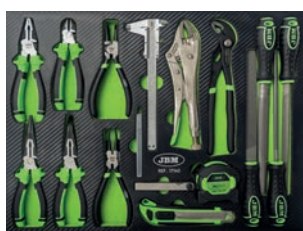

17141 369,00€



17142 222,00€



17143 313,00€



17144 385,00€



54718 1.990,00€

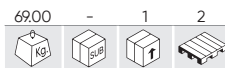

CARRINHO DE FERRAMENTAS DE 8 GAVETAS - EQUIPADO

Capacidade da gaveta grande	35Kg
Capacidade de carga do tableiro superior	55Kg
Capacidade	280Kg
Peso	56,00Kg
Dimensões (CxLxA)	771x466x960mm



CARRINHOS DE FERRAMENTAS COM 7 GAVETAS

REF.	COR						€
53912		CARRINHO DE FERRAMENTAS XL DE 7 GAVETAS VERDE - EQUIPADO	74.50	-	1	4	1.280,00€
53869		CARRINHO DE FERRAMENTAS XL COM 7 GAVETAS - VERDE - VAZIO	74.50	-	1	4	990,00€
53913		CARRINHO DE FERRAMENTAS XL DE 7 GAVETAS VERMELHO - EQUIPADO	74.50	-	1	4	1.280,00€
53870		CARRINHO DE FERRAMENTAS XL COM 7 GAVETAS - VERMELHO - VAZIO	74.50	-	1	4	990,00€

Material	Acero/Steel, ABS
Gavetas	7
Medidas da gaveta pequena	705x400x74mm
Dimensões gaveta grande	705x400x151.5mm
Capacidade da gaveta pequena	25Kg
Capacidade da gaveta grande	35Kg
Capacidade de carga do tabuleiro superior	40Kg
Capacidade	300Kg
Peso	74,50Kg
Dimensões (CxLxA)	980x510x984mm

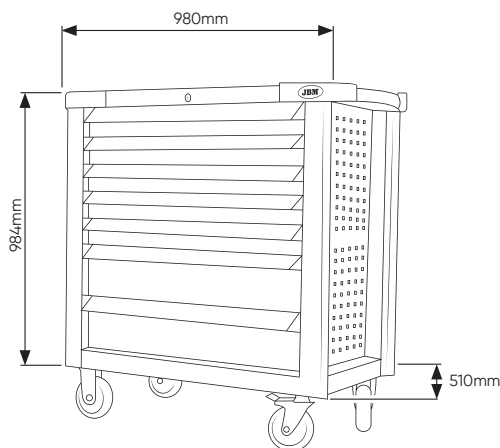

53912

REPOSIÇÕES DISPONÍVEIS

53869

REPOSIÇÕES DISPONÍVEIS

53913

REPOSIÇÕES DISPONÍVEIS

53870

REPOSIÇÕES DISPONÍVEIS

ACOPLAMENTO QUADRADO

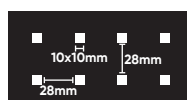

O CARRO COM DOTAÇÃO CONTÉM:

<p>14296 122,00€</p>	<p>14297 93,00€</p>	<p>14298 55,00€</p>	<p>14299 93,00€</p>
<p>15122 80,00€</p>	<p>15155 61,00€</p>	<p>15161 62,00€</p>	<p>15514 9,35€</p>

54690 988,00€

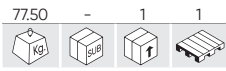

CARRINHO DE FERRAMENTAS XL COM 8 GAVETAS - VAZIO

Material	Acero/Steel, ABS
Gavetas	8
Dimensões da gaveta	750x400x75mm
Dimensões gaveta grande	750x400x150mm
Capacidade da gaveta pequena	35Kg

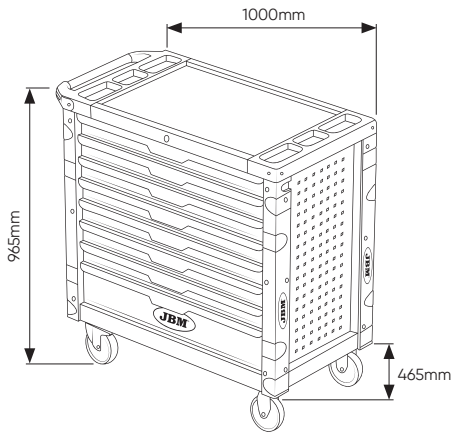

ACOPLAMENTO QUADRADO

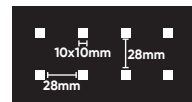

O CARRO COM DOTAÇÃO CONTÉM:

54688 3.150,00€

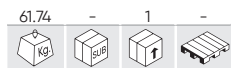

CARRO DE FERRAMENTAS XL DE 8 GAVETAS - EQUIPADO

Capacidade da gaveta grande	35Kg
Capacidade de carga do tableiro superior	55Kg
Capacidade	335Kg
Peso	77,50Kg
Dimensões (CxLxA)	1000x465x965mm



16873 145,00€ **16874** 454,00€ **16875** 433,00€ **16876** 369,00€



16877 290,00€ **16878** 174,00€ **16879** 315,00€



CARROS DE FERRAMENTAS COM 7 GAVETAS

REF.	COR						€
54006	●	CARRINHO DE FERRAMENTAS COM 7 GAVETAS VAZIAS - VERDE	55.00	-	1	4	490,00€
53762	●	CARRINHO DE FERRAMENTAS COM 7 GAVETAS VAZIAS - VERMELHO	55.00	-	1	4	490,00€
53768	●	CARRINHO DE FERRAMENTAS COM 7 GAVETAS VAZIAS - AZUL	55.00	-	1	4	490,00€
53761	●	CARRINHO DE FERRAMENTAS COM 7 GAVETAS VAZIA - CINZA	55.00	-	1	4	490,00€

Material	Acero/Steel, ABS
Gavetas	7
Dimensões da gaveta	533x400x74mm
Dimensões gaveta grande	533x400x151.5mm
Capacidade da gaveta pequena	30Kg
Capacidade da gaveta grande	30Kg
Capacidade de carga do tabuleiro superior	55Kg
Capacidade	300Kg
Peso	55,00Kg
Dimensões (CxLxA)	775x466x960mm

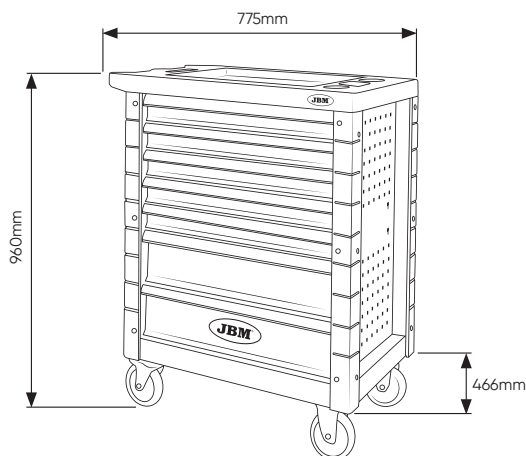

54006



REPOSIÇÕES DISPONÍVEIS

53762



REPOSIÇÕES DISPONÍVEIS

53768



REPOSIÇÕES DISPONÍVEIS

53761



REPOSIÇÕES DISPONÍVEIS

ACOPLAMENTO QUADRADO

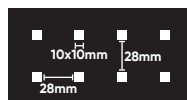

MUDANÇA DE DESIGN

Atualizamos o design do carrinho verde. Agora, ao adquirir a REF.54006, você receberá o carrinho correspondente à REF.54503.

Na JBM estamos sempre inovando e pensando em nossos consumidores, por isso agora oferecemos:

- Um design aprimorado.
- Acabamentos mais definidos, pensados para o uso diário.
- Materiais mais robustos e resistentes, ideais para trabalhos em condições extremas.



ESCOLHA O CARRO COM OS MÓDULOS MAIS ADEQUADOS ÀS SUAS NECESSIDADES

ESPECIAL FERRAMENTAS MANUAIS

REF.	GAVETAS	COR	EQUIPADO	PEÇAS	MATERIAL					€
53904	7		Com ferramentas	172	Aço	70.00	-	1	4	790,00€
53686	7		Com ferramentas	172	Aço	70.00	-	1	4	790,00€
53767	7		Com ferramentas	172	Aço	70.00	-	1	4	790,00€
53661	7		Com ferramentas	172	Aço	70.00	-	1	4	790,00€



O CARRO COM DOTAÇÃO CONTÉM:

53708 325,00€



KIT DE 4 MÓDULOS DE CARBONO EVA PARA FERRAMENTAS

14296 122,00€



14297 93,00€



14298 55,00€



14299 93,00€



ESCOLHA O CARRO COM OS MÓDULOS MAIS ADEQUADOS ÀS SUAS NECESSIDADES

ESPECIAL CAMINHÃO

REF.	GAVETAS	COR	EQUIPADO	PEÇAS	MATERIAL					€
54240	7		Com ferramentas	224	Aço	110.50	-	1	4	1.887,00€
54238	7		Com ferramentas	224	Aço	110.50	-	1	4	1.887,00€
54239	7		Com ferramentas	224	Aço	110.50	-	1	4	1.887,00€
54237	7		Com ferramentas	224	Aço	110.50	-	1	4	1.887,00€

O CARRO COM DOTAÇÃO CONTÉM:

54134 1.485,00€



MÓDULO DE FERRAMENTAS DE REPARAÇÃO DE CAMIÕES

15730 289,00€



15731 214,00€



15732 294,00€



15733 118,00€



15734 289,00€



15735 156,00€











15736 489,00€



ESCOLHA O CARRO COM OS MÓDULOS MAIS ADEQUADOS ÀS SUAS NECESSIDADES

ESPECIAL KIT DE BLOQUEIO

REF.	GAVETAS	COR	EQUIPADO	PEÇAS	MATERIAL					€
53951	7		Com ferramentas	250	Aço	94.70	-	1	4	1.794,00€
53952	7		Com ferramentas	250	Aço	94.70	-	1	4	1.794,00€
54501	7		Com ferramentas	250	Aço	94.70	-	1	4	1.794,00€
54502	7		Com ferramentas	250	Aço	94.70	-	1	4	1.794,00€



O CARRO COM DOTAÇÃO CONTÉM:

53775 1.378,00€



MÓDULO DE 6 FERRAMENTAS DE SINCRONIZAÇÃO DE MOTOR

53769 195,00€



53770 221,00€



53771 158,00€



53772 257,00€



53773 327,00€



53774 208,00€



ESCOLHA O CARRO COM OS MÓDULOS MAIS ADEQUADOS ÀS SUAS NECESSIDADES

ESPECIAL VEÍCULOS ELÉTRICOS

REF.	GAVETAS	COR	EQUIPADO	PEÇAS	MATERIAL					€
54236	7		Com ferramentas	24	Aço	67.70	-	1	4	1.856,00€
54234	7		Com ferramentas	24	Aço	67.70	-	1	4	1.856,00€
54235	7		Com ferramentas	24	Aço	67.70	-	1	4	1.856,00€
54233	7		Com ferramentas	24	Aço	67.70	-	1	4	1.856,00€



CONTÉM

REF.	DESCRIÇÃO	PEÇAS					€
52162	TERMÓMETRO LÁSER -50°C A 550°C	1	0.17	6	72	576	38,00€
53940	POSTE DE PLÁSTICO PARA CORRENTE - AMARELO / PRETO	4	0.55	-	6	90	15,50€
54326	CORRENTE DE PVC - 7M - AMARELO/PRETO	4	0.30	-	20	600	8,50€
53942	ELO DE FECHAR PRETO	8	0.01	50	5000	75000	0,50€
54093	MÓDULO EVA DE FERRAMENTA ISOLADA	1	2.88	-	4	64	441,00€
54114	MEDIDOR DE ISOLAMENTO	1	1.48	-	10	100	248,00€
54129	TAPETE ISOLANTE CLASSE 0	1	2.10	-	1	200	110,00€
54130	LUVAS ISOLANTES PARA TRABALHOS SOB TENSÃO T.9	1	0.35	-	21	220	65,00€
54132	PROTEÇÃO FACIAL ISOLANTE PARA TRABALHOS SOB TENSÃO	1	0.70	-	1	39	190,00€
54241	GANCHO DE RESGATE ISOLADO - 45KV	1	1.10	-	1	50	120,00€
54322	CONJUNTO DE 2 SINAIS DE AVISO DE ALTA TENSÃO	1	0.05	25	100	-	21,00€

54503

490,00€

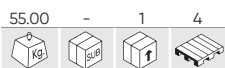

CARRINHO DE FERRAMENTAS COM 7 GAVETAS VAZIAS VERDE

Material	Acero/Steel, ABS
Gavetas	7
Dimensões da gaveta	533x400x74mm
Dimensões gaveta grande	533x400x151.5mm
Capacidade da gaveta pequena	35Kg
Capacidade da gaveta grande	35Kg
Comprimento do alargamento da indução	773X466.9X49.5mm
Capacidade de carga do tabuleiro superior	55Kg
Capacidade	300Kg
Peso	55,00Kg
Dimensões (CxLxA)	775x466x960mm

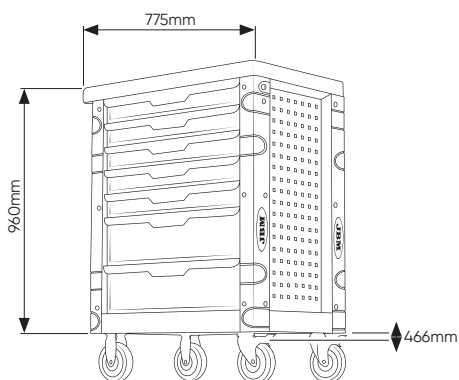

54503



REPOSIÇÕES DISPONÍVEIS

54389



REPOSIÇÕES DISPONÍVEIS

54389

790,00€

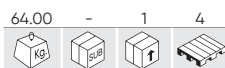

CARRINHO DE FERRAMENTAS DE 7 GAVETAS VERDE - EQUIPADO



ACOPLAMENTO QUADRADO

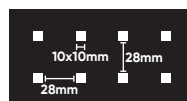

O CARRO COM DOTAÇÃO CONTÉM:

53708

325,00€



KIT DE 4 MÓDULOS DE CARBONO EVA PARA FERRAMENTAS

14296

122,00€



14297

93,00€



14298

55,00€

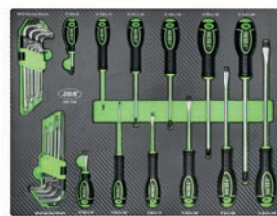

14299

93,00€



54834

565,00€

45,10 - 1 4

NEW

CARRO DE FERRAMENTAS DE 7 GAVETAS VERDE - EQUIPADO

Peças	154
Material	Acero/Steel
Gavetas	7
Medidas da gaveta pequena	400x554x74mm
Dimensões gaveta grande	400x554x151mm
Capacidade da gaveta pequena	35Kg
Capacidade da gaveta grande	45Kg
Capacidade de carga do tabuleiro superior	55Kg
Peso	45,10Kg
Dimensões (CxLxA)	757x453x807mm

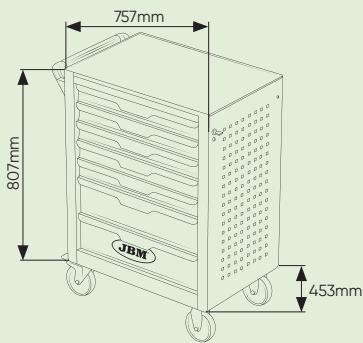

CONTÉM

14296 122,00€



14297 93,00€



17775 99,00€



REPOSIÇÕES DISPONÍVEIS

ACOPLAMENTO QUADRADO

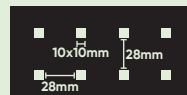

53867

849,00€

73,45 - 1 4

CARRINHO DE FERRAMENTAS COM 9 GAVETAS E SEPARADORES - VERDE

Peças	Vacio/Empty
Material	Acero/Steel, ABS
Gavetas	9
Dimensões da gaveta	775x468x75mm
Capacidade das gavetas	25Kg
Capacidade de carga do tabuleiro superior	40Kg
Capacidade	300Kg
Contém	Separadores/Organizers
Peso	73,45Kg
Dimensões (CxLxA)	775x468x960mm

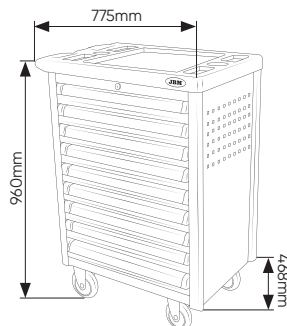

CONTÉM

REF.	mm					€
15073	174x53mm	0.05	10	200	-	1,00€
15076	396x53mm	0.30	5	50	-	4,60€



ACOPLAMENTO QUADRADO

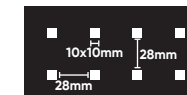

CARROS DE FERRAMENTAS - GAVETAS IGUAIS

REF.	GAVETAS	COR					€
54295	7		49.00	-	1	4	500,00€
54296	8		51.00	-	1	4	520,00€
54297	9		52.30	-	1	4	540,00€

ESPECIFICAÇÕES TÉCNICAS

Medidas gaveta (REF.54295)	97mm	775mm	468mm
Medidas gaveta (REF.54296)	85mm	775mm	468mm
Medidas gaveta (REF.54297)	75mm	775mm	468mm
Capacidade das gavetas (REF.54295)	25Kg		
Capacidade das gavetas (REF.54296)	25Kg		
Capacidade das gavetas (REF.54297)	25Kg		

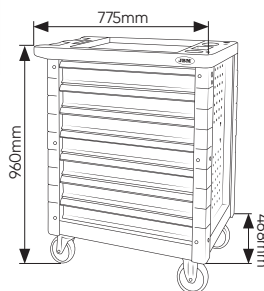

ACOPLAMENTO QUADRADO

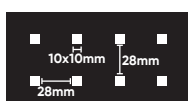

54518

457,50€

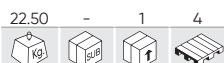

CARRINHO MODULAR COM 4 CAIXAS EMPILHÁVEIS

Material	PP modificado/Modified PP
Módulos	4
Medida do primeiro módulo	555x340x115mm
Medida do segundo módulo	550x340x160mm
Medida do terceiro módulo	580x340x410mm
Medida do quarto módulo	550x340x310mm
Capacidade do primeiro módulo	10Kg
Capacidade do segundo módulo	20Kg
Capacidade do terceiro módulo	40Kg
Capacidade do quarto módulo	30Kg
Fecho selado	Si/Yes
Capacidade	100Kg
Peso	22,50Kg
Contém	54519, 54520, 54535, 54537
Dimensões (CxLxA)	580x450x970mm

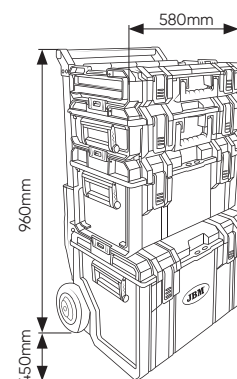

REPOSIÇÕES DISPONÍVEIS



REF.	DESCRIÇÃO					€
A 54519	CAIXA DE FERRAMENTAS EMPILHÁVEL COM ORGANIZADOR DE PEÇAS (12 COMPARTIMENTOS)	3.60	-	1	30	72,00€
B 54520	CAIXA DE FERRAMENTAS EMPILHÁVEL COM 2 ORGANIZADORES LATERAIS DE PEÇAS (11 COMPARTIMENTOS)	4.00	-	1	24	72,00€
C 54535	CAIXA DE FERRAMENTAS EMPILHÁVEL COM RODAS (85L)	10.80	-	1	10	226,00€
D 54537	CAIXA DE FERRAMENTAS EMPILHÁVEL (40L)	4.90	-	1	12	102,00€

54504

299,00€

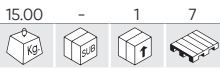

CARRINHO MODULAR - SEM FERRAMENTAS

Material	Acero/Steel, ABS
Gavetas	3
Módulos	3
Medida do primeiro módulo	500x310x240mm
Medida do segundo módulo	500x310x170mm
Medida do terceiro módulo	500x310x330mm
Capacidade do primeiro módulo	12,00L
Capacidade do segundo módulo	10,00L
Capacidade do terceiro módulo	20,00L
Medidas da gaveta pequena	390x215x60mm
Medidas de gaveta média	430x220x130mm
Dimensões gaveta grande	405x190x270mm
Capacidade	40Kg
Peso	15,00Kg
Dimensões (CxLxA)	500x310x720mm

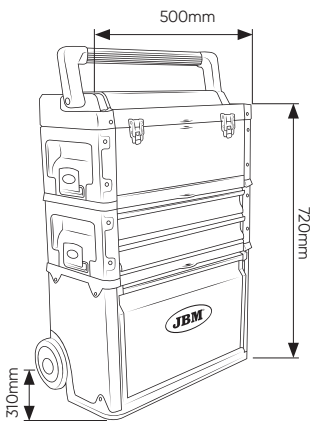

53672

440,00€

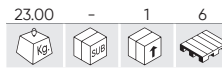

CARRINHO MODULAR - EQUIPADO



53672



REPOSIÇÕES DISPONÍVEIS

O CARRO COM DOTAÇÃO CONTÉM:

14327

198,00€

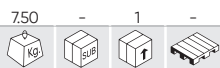

CONJUNTO DE 3 MÓDULOS DE CARBONO EVA PARA FERRAMENTAS - PARA 53672



	1/2"	x11	8, 10, 11, 12, 13, 14, 16, 17, 19, 21, 22mm
	1/4"	x13	4, 4.5, 5, 5.5, 6, 7, 8, 9, 10, 11, 12, 13, 14mm
	1/2"	x1	
	1/4"	x1	
	1/2"	x2	125, 300mm
	1/4"	x2	50, 100mm
		x1	180mm
		x1	160mm
		x2	160, 180mm
	+	x2	PH2x125, PH1x100mm
	-	x2	6x150, 5x100mm
		x9	8, 9, 10, 11, 12, 13, 14, 17, 19mm

		x1	250mm
		x1	300g
		x1	250mm
		x1	200mm
		x8	1,5x8mm
		x1	3mm
	1/4"	x32	
	1/4"	x1	
	1/4"	x1	
	1/2"	x1	72
	1/4"	x1	72

54388

366,00€

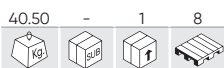

CARRINHO PARA DIAGNÓSTICO

Peças	Vazio/Empty
Material	Acero/Steel
Gavetas	1
Dimensões da gaveta	433x397x275,5mm
Comprimento do alargamento da indução	433x436x188,5mm
Medidas da bandeja central	433x402,5x249,5mm
Medidas da bandeja inferior	433x397x198mm
Capacidade	90,00Kg
Peso	40,50Kg
Dimensões (CxLxA)	513x4397x1050,7mm

REPOSIÇÕES
DISPONÍVEIS

55000

197,00€



NEW

CARRINHO COM 3 BANDEJAS E SUPORTES
PARA FERRAMENTAS DE DETAILING

Material	PP
Bandejas	3
Medidas das bandejas	430x655mm
Capacidade das bandejas	45Kg
Capacidade	135Kg
Peso	11,3Kg
Dimensões (CxLxA)	870x680x430mm



55001

170,00€



NEW

CARRINHO COM 3 BANDEJAS DOBRÁVEIS

Material	PP, Alumínio/Aluminium
Bandejas	3
Medidas das bandejas	430x655mm
Capacidade das bandejas	22Kg
Capacidade	65Kg
Peso	8,80Kg
Dimensões (CxLxA)	860x380x720mm



51576

125,00€

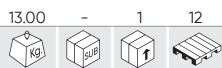

CARRO COM 3 BANDEJAS

Material	Acero/Steel SPCC
Bandejas	3
Medidas das bandejas	790x370x80mm
Capacidade das bandejas	50Kg
Capacidade	100Kg
Peso	13,00Kg
Dimensões (CxLxA)	885x380x795mm



52373

252,00€

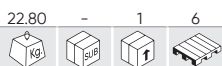

CARRO COM 3 BANDEJAS MAXI

Material	Acero/Steel SPCC
Bandejas	3
Medidas das bandejas	745x390x88mm
Capacidade das bandejas	70Kg
Capacidade	150Kg
Peso	22,80Kg
Dimensões (CxLxA)	1020x635x800mm



54499

141,00€

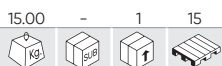

CARRINHO DE FERRAMENTAS 3 PRATELEIRAS 1 GAVETA

Material	Acero/Steel SPCC
Gavetas	1
Dimensões da gaveta	595X315X60mm
Capacidade das gavetas	25Kg
Bandejas	3
Medidas das bandejas	700X350X60mm
Capacidade das bandejas	50Kg
Capacidade	150Kg
Peso	15,00Kg
Dimensões (CxLxA)	830x350x750mm



ACOPLAMENTO QUADRADO

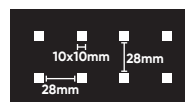

54839

219,00€



NEW

CARRINHO COM 3 GAVETAS, 1 BANDEJA E GRELHAS LATERAIS

Material	Acero/Steel SPCC
Gavetas	3
Medidas das gavetas	554x400x74mm
Capacidade da gaveta grande	554x400x151mm
Bandejas	1
Medidas das bandejas	533x398mm
Peso	26,80Kg
Dimensões (CxLxA)	770x450x940mm



ACOPLAMENTO QUADRADO

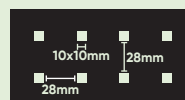



53708 **325,00€**



KIT DE 4 MÓDULOS DE CARBONO EVA PARA FERRAMENTAS

14296 **122,00€**

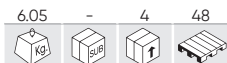

14296	
	1/2" x17 10, 11, 12, 13, 14, 15, 16, 17, 18, 19, 20, 21, 22, 24, 27, 30, 32mm
	1/4" x13 4, 4.5, 5, 5.5, 6, 7, 8, 9, 10, 11, 12, 13, 14mm
	1/2" x5 14, 15, 17, 19, 22mm
	1/4" x8 6, 7, 8, 9, 10, 11, 12, 13mm
	1/2" x8 E10, E11, E12, E14, E16, E18, E20, E24
	1/4" x5 E4, E5, E6, E7, E8
	T2 x2 1/2", 1/4"
	1/2" x2 125, 250mm
	1/4" x2 50, 100mm
	x2 1/2", 1/4"
	x1 F1/2" - M3/8"
	1/2" x2 16, 21mm
	x3 1.5, 2, 2.5mm
	1/4" x1
	1/4" x1
	1/2" x1 8mm
	x2 PH1, PH2
	x2 PZ1, PZ2
	1/4" x4 3, 4, 5, 6mm
	x3 SL4, SL5.5, SL6.5
	x7 T8, T10, T15, T20, T25, T27, T30
	x2 PH3, PH4
	x2 PZ3, PZ4
	8mm x5 7, 8, 10, 12, 14mm
	x3 SL8, SL10, SL12
	x5 T40, T45, T50, T55, T60

14297 **93,00€**



14298 **55,00€**

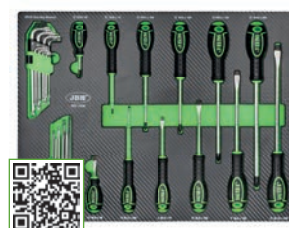

14297	
	x8 6x7, 8x9, 10x11, 12x13, 14x15, 16x17, 18x19, 20x22mm
	x17 6, 7, 8, 9, 10, 11, 12, 13, 14, 15, 16, 17, 18, 19, 20, 21, 24mm

14298	
	x6 PH2x38, PH0x75, PH1x100, PH2x100, PH3x150, PH4x200
	x6 SL6x38, SL3x100, SL5x75, SL6x100, SL8x150, SL10x200
	x9 1.5, 2, 2.5, 3, 4, 5, 6, 8, 10mm
	x9 10, 15, 20, 25, 27, 30, 40, 45, 50mm

14299	
	x1 35mm
	x1 450g
	x1 10"
	x1 8"
	x1 8"
	x1 10"
	x1 7,5"
	x1 3m

54689

2.162,00€

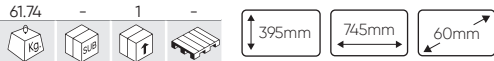

KIT DE 7 MÓDULOS DE CARBONO EVA PARA FERRAMENTAS

16873

145,00€

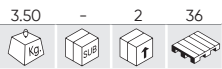

16874

454,00€

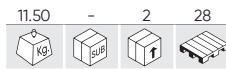

16875

433,00€

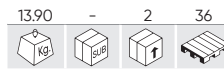

16876

369,00€

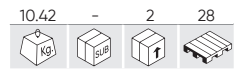

16877

290,00€

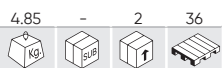

16878

174,00€

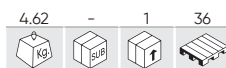

16879

315,00€

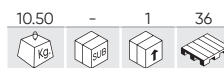

16873	
	x4 PH0x75, 1x100, 2x125, 3x150mm
	x6 SL3x75, 3.5x75, 4x100, 5.5x125, 6.5x150, 8x200mm
	x12 T5x100, 6x100, 7x100, 8x100, 9x100, 10x100, 15x100, 20x100, 25x100, 27x100, 30x100, 40x100mm
	x2 6x100, 8x128mmL
	x2 1/4"x115, 5/16"x115mmL
	x2 132mmL
	x1 11x200, 16x300mmL
	x1
	x1
	x1
16874	
	x12 4, 4.5, 5, 5.5, 6, 7, 8, 9, 10, 11, 12, 13mm
	x12 4, 4.5, 5, 5.5, 6, 7, 8, 9, 10, 11, 12, 13mm
	x6 E4, 5, 6, 7, 8, 10
	x6 E4, 5, 6, 7, 8, 10
	x3 50, 100, 150mmL
	x1 1/4"
	x1 3/8"(F) x 1/4"(M)
	x1 1/4"
	x7 H3, 4, 5, 6, 7, 8, 10
	x3 PH0, 1, 2
	x3 PZ0, 1, 2
	x3 SL4, 5.5, 6
	x7 IPR10, 15, 20, 25, 27, 30, 40
	x8 T8, 10, 15, 20, 25, 27, 30, 40
	x8 T8H, T10H, T15H, T20H, T25H, T27H, T30H, T40H
	x4 45, 75, 150, 250mm
	x1 1/2"(F) x 3/8"(M)
	x3 16, 18, 21mm
	x3
	x1
	x17 6, 7, 8, 9, 10, 11, 12, 13, 14, 15, 16, 17, 18, 19, 20, 21, 22mm
	x17 6, 7, 8, 9, 10, 11, 12, 13, 14, 15, 16, 17, 18, 19, 20, 21, 22mm

	x10 E4, 5, 6, 7, 8, 10, 11, 12, 14, 16
	x10 E4, 5, 6, 7, 8, 10, 11, 12, 14, 16
	x3 PH1, 2, 3
	x3 PZ1, 2, 3
	x3 SL5.5, 6, 7
	x10 H3, 4, 5, 5.5, 6, 7, 8, 9, 10, 12
	x12 T8, 10, 15, 20, 25, 27, 30, 40, 45, 50, 55, 60
	x12 T8H, T10H, T15H, T20H, T25H, T27H, T30H, T40H, T45H, T50H, T55H, T60H
	x6 M5, 6, 8, 9, 10, 12
	x8 R4, 5, 6, 7, 8, 9, 10, 12
	x3
	x1
	x1 20-120Nm
	x1 UNIVERSAL
	x1 450mmL
	x1 250mmL
16875	
	x22 8, 9, 10, 11, 12, 13, 14, 15, 16, 17, 18, 19, 20, 21, 22, 23, 24, 26, 27, 28, 30, 32mm
	x22 8, 9, 10, 11, 12, 13, 14, 15, 16, 17, 18, 19, 20, 21, 22, 23, 24, 26, 27, 28, 30, 32mm
	x8 E10, 11, 12, 14, 16, 18, 20, 24
	x8 E10, 11, 12, 14, 16, 18, 20, 24
	x6 H5, 6, 7, 8, 10, 12 - 100mmL
	x4 T40, 45, 50, 55 - 100mmL
	x5 M6, 8, 10, 12, 14 - 100mmL
	x3 17, 19, 21mm
	x1 20-200Nm
	x1 255mm
	x2 125, 250mmL
	x1 380mmL
	x1 UNIVERSAL
16876	
	x26 6, 7, 8, 9, 10, 11, 12, 13, 14, 15, 16, 17, 18, 19, 20, 21, 22, 23, 24, 25, 26, 27, 28, 29, 30, 32mm

	x8 6x7, 8x9, 10x11, 12x13, 14x15, 16x17, 18x19, 20x22		
	x7 6x7, 8x9, 10x11, 12x13, 14x15, 16x17, 18x19		
	x12 8, 9, 10, 11, 12, 13, 14, 15, 16, 17, 18, 19mm		
16877			
	x4 7"		x1
	x3 7" (x1), 8" (x2)		x1
	x1 7"		x3
	x1 10"		x1
	x1 10"		x10
	x1 5m		x1
	x1 10"		x1
	x1		x1
	x1		x1
16878			
	x4 8"		x1
	x9 H1.5, 2, 2.5, 3, 4, 5, 6, 8, 10		x1
	x9 T10, 15, 20, 25, 27, 30, 40, 45, 50		x1
	x10 4, 5, 5.5, 6, 8, 9, 10, 11, 12, 13mm		x1
	x1 7mm		x1
	x8 H2, H2.5, H3, H4, H5, H6, H7, H8		x1
16879			
	x22 10, 11, 12, 13, 14, 15, 16, 17, 18, 19, 20, 21, 22, 23, 24, 25, 26, 27, 28, 29, 30, 32mm		x1
	x1 125mmL		x1
	x4 140mmL 10, 160mmL 12, 190mmL 18, 220mmL 24		x1
	x1 190mmL 7		x4
	x4 150mmL 3, 180mmL 4, 200mmL 5, 210mmL 6		x3
	x3 185mmL 2, 185mmL 3, 185mmL 4		x1
	x1 185mmL 4		x1
	x1 505gr		x1
	x1 1106gr		x1
	x1 608gr		x1

54134

1.485,00€



MÓDULO DE FERRAMENTAS DE REPARAÇÃO DE CAMIÕES

15730

289,00€

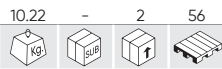

15731

214,00€

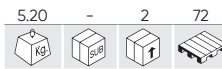

15732

294,00€

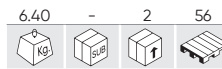

15733

118,00€

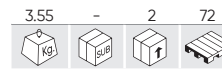

15734

289,00€

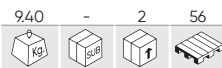

15735

156,00€



15736

489,00€

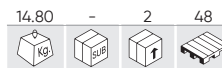

15730

	x10	10, 11, 12, 13, 14, 15, 16, 17, 18, 19mm
	x9	E10, E11, E12, E14, E16, E18, E20, E22, E24
	x6	55mmL H5, H6, H7, H8, H10, H12
	x1	65mmL H14
	1/2"	x5 70mmL H16, H17, H18, H19, H22
		x3 50, 125, 250mm
		x1 430mm
		x1 10mm
		x1
	3/4"	x5 21, 24, 27, 34, 36mm
		x4 24, 30, 32, 36mm
	3/8"	x1 10mm
	1/4"	x3 300, 380, 450mm
		x1 150mm
		x7 H4, H5, H6, H7, H8, H10, H12
		x5 10x30mmL M5, M6, M8, M10, M12
	1/4"	x7 T20, T25, T30, T40, T45, T50, T55
		x7 H4, H5, H6, H7, H8, H10, H12
		x5 10x75mmL M5, M6, M8, M10, M12
		x7 T20, T25, T30, T40, T45, T50, T55

15731

	x12	6x7, 8x9, 10x11, 12x13, 14x15, 16x17, 18x19, 20x22, 21x23, 24x27, 25x28, 30x32mm
	x13	6, 7, 8, 10, 11, 12, 13, 14, 15, 17, 19, 22, 24mm

15732

	x3	10, 13, 17mm
	x3	10x11, 12x13, 14x17mm
	x3	E10xE12, E14xE18, E20xE24
	x5	8x10, 11x13, 14x15, 16x17, 18x19mm
	x4	27, 30, 32, 36mm
	x4	10, 13, 17, 19mm

15733

	x6	PH0x75, PH1x75, PH2x100, PH2x38, PH3x150, PH4x200mmL
	x6	SL3.5x75, SL5x75, SL6x100, SL6x38, SL8x150, SL9.5x200mmL
	x3	10x11, 12x13, 14x15mm
	x5	10x11, 12x13, 14x15, 16x17, 18x19mm

15734

	3/4"	x1 500mm
	3/4"	x1 500mm
		x1 1 Kg
		x6 24, 27, 30, 32, 36, 41mm
		x9 1.5, 2, 2.5, 3, 4, 5, 6, 8, 10mm

15735

	x1	330mm-90°		x1	300mm
	x1	330mm		x1	160mm
	x1	330mm-90°		x1	180mm
	x1	330mm		x1	220mm
	x1	300mm - 45°		x1	250mm
	x1	300mm - 90°			

15736

	1/2"	x10 78mmL 13, 14, 15, 16, 17, 18, 19, 21, 22, 24mm
	3/4"	x9 78mmL 22, 24, 27, 30, 32, 33, 36, 38, 46mm
	1/2"	x2 90mmL 51, 60mm
	1/2"	x6 90mmL T40, T45, T50, T55, T60, T70
	1/2"	x4 78mmL H6, H8, H14, H17
	3/4"	x3 100mmL T80, T90, T100
	1/2"	x1 40mmL M18
		x1 1/2"(M)x3/4"(H)
		x1 3/4"(M)x1/2"(H)
		x1 125mm
	1/2"	x1
	3/4"	x1

54720

1.549,00€

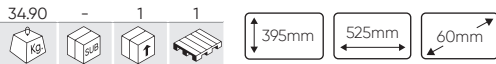

CONJUNTO DE 7 TABULEIROS PARA CARRINHO DE FERRAMENTAS

17138 245,00€

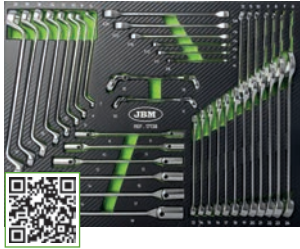
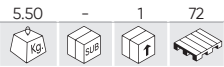

17139 130,00€

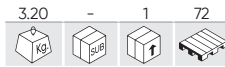

18463 167,00€

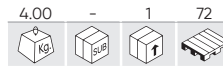

17141 369,00€

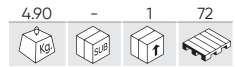

17142 222,00€

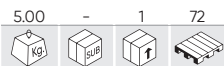

17143 313,00€



17144 385,00€



- 17138**
- x19 6, 7, 8, 9, 10, 11, 12, 13, 14, 15, 16, 17, 18, 19, 20, 21, 22, 23, 24mm
 - x8 6x7, 8x9, 10x11, 12x13, 14x15, 16x17, 18x19, 21x23mm
 - x6 E6x8, E7x11, E10x12, E14x18, E16x22, E20x24
 - x6 8x9, 10x11, 12x13, 14x15, 16x17, 18x19mm
 - x2 10x11, 12x13mm

- 17139**
- x9
 - x9
 - x5 PH0x75, PH1x100, PH2x125, PH2x38, PH3x150
 - x5 SL4x100, SL5.5x125, SL6.5x150, SL6x38, SL8x200
 - x9 T8, T9, T10, T15, T20, T25, T27, T30, T40
 - x4 6, 7, 8, 10mm

- 18463**
- x2 160mm (Internal)
 - x2 160mm (External)
 - x4 160, 180, 200, 210mm
 - x1 0.05-1mm
 - x4 200mm
 - x1 235mm
 - x1 220mm
 - x1 5m
 - x1 18mm
 - x10 0,5x18x100mm
 - x1 240mm

- 17141**
- x9 3/8", 5/16", 7, 8, 10, 11, 12, 13, 14mm
 - x1 10mm
 - x6 8, 9, 10, 12, 14, 17mm
 - x1 M16
 - x1 10mm
 - x1 10mm
 - x2 14, 19mm
 - x4 27, 32, 36, 74mm
 - x5 15, 17, 19, 21, 22mm
 - x1 162mm
 - x1 270mm
 - x1 22mm
 - x1 Ø65-125mm
 - x1 50-125mm
 - x2 Ø4, 5mm
 - x1 175mm
 - x2
 - x1 250mm

- 17142**
- x1 150-675mm
 - x1 510mm
 - x1 85Lm
 - x1 1000g
 - x1 400g
 - x1 400g
 - x4 Ø 3, 4, 5, 6mm
 - x5 Ø 3, 4, 5, 6, 8mm
 - x3 7, 18 20mm
 - x1 25x200mm
 - x1 225mm
 - x1 195x30mm
 - x1 370mm

- 17143**
- x19 10, 11, 12, 13, 14, 15, 16, 17, 18, 19, 20, 21, 22, 24, 26, 27, 28, 30, 32mm
 - x2 120, 250mm
 - x1 17
 - x1 17
 - x7 TS10, 15, 20, 25, 27, 30, 40
 - x1 PH2
 - x1 SL5.5
 - x5 H3, 4, 5, 6, 7
 - x7 T10, 15, 20, 25, 27, 30, 40
 - x7 T10H, T15H, T20H, T25H, T27H, T30H, T40H
 - x10 4, 5, 6, 7, 8, 9, 10, 11, 12, 13mm
 - x2 50, 100mm
 - x2 17
 - x1
 - x6 8, 9, 10, 12, 14, 16mm
 - x12 8, 9, 10, 11, 12, 13, 14, 15, 16, 17, 18, 19mm
 - x12 8, 9, 10, 11, 12, 13, 14, 15, 16, 17, 18, 19mm
 - x2 75, 150mm
 - x3 16, 18, 21mm
 - x1
 - x3 3/8"Fx1/4"M, 1/2"Fx3/8"M, 3/8"Fx1/2"M
 - x1 14mm
 - x1 250mm
 - x2 235, 265mm

- 17144**
- x19 H10 (140mm), 5, 6, 7, 8, 10, 12, 14 (100mm), 6 (240mm), 5, 6, 7, 8, 9, 10, 12, 14, 17, 19
 - x5 R7, 8 (240mm), 10 (140mm), 9, 10 (100mm)
 - x13 M5, 6, 8, 9, 10, 12, 14, 16 (55mm), 6, 8, 10, 12, 14 (100mm)
 - 1/2" x19 T25, 27, 30, 40, 45, 50, 55, 60, 70 (100mm), 25, 27, 30, 40, 45, 50, 55, 60, 70 (140mm), 70
 - x1 M18 (78mm)
 - x6 13, 14, 15, 17, 19, 21mm
 - x9 E10, 11, 12, 14, 16, 18, 20, 22, 24,
 - x1
 - 1/4" x5 6, 8, 10, 11, 12mm
 - x31
 - x2

17728

445,00€

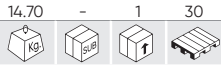

TABULEIRO COMPLETO PARA GAVETA SUPERIOR 54510



1/2"	x17	10, 11, 12, 13, 14, 15, 16, 17, 18, 19, 20, 21, 22, 24, 27, 30, 32mm
1/4"	x13	4, 4.5, 5, 5.5, 6, 7, 8, 9, 10, 11, 12, 13, 14mm
1/2"	x5	14, 15, 17, 19, 22mm
1/4"	x8	6, 7, 8, 9, 10, 11, 12, 13mm
1/2"	x8	E10, E11, E12, E14, E16, E18, E20, E24
1/4"	x5	E4, E5, E6, E7, E8
⊕	x2	1/2", 1/4"
1/2"	x2	125, 250mm
1/4"	x2	50, 100mm
	x2	1/2", 1/4"
	x1	F1/2" - M3/8"
1/2"	x2	16, 21mm
	x3	1.5, 2, 2.5mm
1/4"	x1	
1/4"	x1	
1/2"	x1	8mm
⊕	x2	PH1, 2
⊕	x2	PZ1, 2
1/4"	x4	3, 4, 5, 6mm
⊖	x3	SL4, 5.5, 6.5
⊖	x7	T8, 10, 15, 20, 25, 27, 30
⊕	x2	PH3, 4
⊕	x2	PZ3, 4
8mm	x5	7, 8, 10, 12, 14mm
⊖	x3	SL8, 10, 12
⊖	x5	T40, 45, 50, 55, 60

17729

445,00€

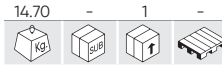

MÓDULO DE FERRAMENTAS COMPLETO PARA REF. 54511



	x8	6x7, 8x9, 10x11, 12x13, 14x15, 16x17, 18x19, 20x22mm
	x17	6, 7, 8, 9, 10, 11, 12, 13, 14, 15, 16, 17, 18, 19, 20, 21, 24mm
⊕	x6	PH2x38, PH0x75, PH1x100, PH2x100, PH3x150, PH4x200
⊖	x6	SL6x38, SL3x100, SL5x75, SL6x100, SL8x150, SL10x200
	x9	1.5, 2, 2.5, 3, 4, 5, 6, 8, 10mm
	x9	10, 15, 20, 25, 27, 30, 40, 45, 50mm
	x1	35mm
	x1	450g
	x1	10"
	x1	8"
	x1	8"
	x1	8"
	x1	10"
	x1	7.5"
	x1	3m

54836

318,00€



NEW

CONJUNTO DE 3 MÓDULOS EM CARBONO EVA PARA CARRINHO DE FERRAMENTAS

14296

122,00€

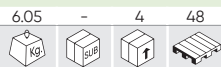

1/2"	x17	10, 11, 12, 13, 14, 15, 16, 17, 18, 19, 20, 21, 22, 24, 27, 30, 32mm
1/4"	x13	4, 4.5, 5, 5.5, 6, 7, 8, 9, 10, 11, 12, 13, 14mm
1/2"	x5	14, 15, 17, 19, 22mm
1/4"	x8	6, 7, 8, 9, 10, 11, 12, 13mm
1/2"	x8	E10, E11, E12, E14, E16, E18, E20, E24
1/4"	x5	E4, E5, E6, E7, E8
⊕	x2	1/2", 1/4"
1/2"	x2	125, 250mm
1/4"	x2	50, 100mm
	x2	1/2", 1/4"
	x1	F1/2" - M3/8"
1/2"	x2	16, 21mm
	x3	1.5, 2, 2.5mm

14297

93,00€



1/4"	x1	
1/4"	x1	
1/2"	x1	8mm
⊕	x2	PH1, PH2
⊕	x2	PZ1, PZ2
1/4"	x4	3, 4, 5, 6mm
⊖	x3	SL4, SL5.5, SL6.5
⊖	x7	T8, T10, T15, T20, T25, T27, T30
⊕	x2	PH3, PH4
⊕	x2	PZ3, PZ4
8mm	x5	7, 8, 10, 12, 14mm
⊖	x3	SL8, SL10, SL12
⊖	x5	T40, T45, T50, T55, T60

17775

99,00€



14297	x8	6x7, 8x9, 10x11, 12x13, 14x15, 16x17, 18x19, 20x22mm
	x17	6, 7, 8, 9, 10, 11, 12, 13, 14, 15, 16, 17, 18, 19, 20, 21, 24mm
17775	x5	SL3x75, 4x75, 5.5x125, 6.5x150, 8x200
	x3	PH1x100, 2x100, 3x150
	x9	1.5, 2, 2.5, 3, 4, 5, 6, 8, 10mm
	x1	175mm
	x1	240mm
	x1	180mm
	x1	200mm



15681

143,00€

2.70 - 4 48
 Kg SUB f Pallet
 380mm 500mm 30mm

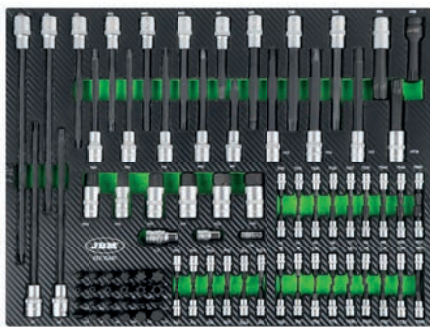

- x3 1/2", 3/8" (8mm), 1/4" (6mm)
- x5 7, 8, 10, 12, 14mm
- x2 PH3, PH4
- x2 PZ3, PZ4
- x3 SL8, SL10, SL12
- x6 T40, T45, T50, T55, T60, T70
- x6 T40, T45, T50, T55, T60, T70

- x9 H7 (230mmL), H10, H11, H13 (140mmL), H14, H17, H19, H22, H24 (55mmL)
- x6 M9 (100mmL), M10, M12, M14 (140mmL), M16 (53mmL), M16 (100mmL)
- x4 R7, R8 (240mmL), R9 (100mmL), R10 (140mmL)
- x8 T30 (300mmL), T40, T45, T50, T55, T60, T70 (140mmL), T80 (100mmL)
- x1 HT5 (160mmL)
- x1 M18
- x6 H3, H4, H5, H6, H7, H8
- x3 M8, M10, M12
- x4 PH0, PH1, PH2, PH3
- x4 PZ0, PZ1, PZ2, PZ3
- x4 SL4, SL5.5, SL6.5, SL7
- x9 T8, T9, T10, T15, T20, T25, T27, T30, T40
- x9 T8, T9, T10, T15, T20, T25, T27, T30, T40
- x9 TS10, TS15, TS20, TS25, TS27, TS30, TS40, TS45, TS50

15158

63,00€

1.30 - 10 200
 Kg SUB f Pallet
 390mm 180mm 40mm



- x7 8, 10, 11, 13, 14, 17, 19mm

15159

44,00€

0.75 - 10 200
 Kg SUB f Pallet
 390mm 180mm 40mm



- x5 8x10, 11x13, 14x15, 17x19, 20x22mm

15160

45,00€

0.80 - 10 200
 Kg SUB f Pallet
 390mm 180mm 40mm



- x6 8x9, 10x11, 12x13, 14x15, 16x17, 18x19mm

15161

62,00€

2.10 - 10 180
 Kg SUB f Pallet
 390mm 180mm 40mm



- x4 27, 29, 30, 32mm

15316 58,00€

0.85 - 10 300
Kg SUB f

390mm 180mm 40mm

x3 8, 9, 10, 11, 12, 13, 14, 15, 16, 17, 18, 19mm

53943 23,50€

0.80 - 10 240
Kg SUB f

390mm 180mm 40mm

x7 PH0x120, 1x80, 1x100, 2x38, 2x100, 3x150, 4x200

53944 22,50€

0.80 - 10 240
Kg SUB f

390mm 180mm 40mm

x7 SL4x125, 5x80, 5x100, 6x38, 6x100, 8x150, 9x200

53945 21,00€

0.60 - 10 240
Kg SUB f

390mm 180mm 40mm

x7 T8x75, 9x75, 10x75, 15x75, 20x75, 25x100, 27x100

13667 24,00€

0.83 - 10 240
Kg SUB f

385mm 175mm 30mm

x1 253mm

15454 35,40€

1.10 - 10 300
Kg SUB f

390mm 180mm 40mm

x4 8"

15541 29,50€

0.95 - 10 240
Kg SUB f

390mm 180mm 40mm

x3 180, 200, 200mm

15122 80,00€

1.70 - 10 220
Kg SUB f

390mm 180mm 40mm

x12 8, 9, 10, 11, 12, 13, 14, 15, 16, 17, 18, 19mm

15155 61,00€

2.45 - 10 180
Kg SUB f

390mm 180mm 40mm

x11 8, 10, 11, 12, 13, 14, 15, 16, 17, 18, 19mm

15315 30,00€

1.05 - 10 150
Kg SUB f

390mm 180mm 40mm

x5 8"

15156 70,00€

2.05 - 10 180
Kg SUB f

390mm 180mm 40mm

x4 21x23, 24x27, 25x28, 30x32mm

15157 42,00€

0.95 - 10 200
Kg SUB f

390mm 180mm 40mm

x6 6x8, 10x12, 13x14, 15x17, 19x21, 22x24mm





15514 9,35€

0.05 - 10 360

390mm 180mm 40mm



VAZIO

16111 21,50€

0.61 - 10 200

390mm 180mm 40mm



x1 220mm

15799 31,00€

1.35 - 10 240

390mm 180mm 40mm



x1 35mm x1 450g

54032 84,00€

1.45 - 10 240

380mm 175mm 45mm



x12 8, 9, 10, 11, 12, 13, 14, 15, 16, 17, 18, 19mm

52912 94,00€

1.62 - 10 240

390mm 180mm 40mm



x6 E6x7, 8x10, 11x12, 14x16, 18x20, 22x24

54066 83,00€

2.00 - 5 175

390mm 180mm 40mm



x7 8, 10, 12, 13, 14, 17, 19mm

51864 69,00€

1.87 - 10 200

490mm 190mm 34mm



x6 10x11, 12x14, 13x15, 16x18, 17x19, 22x24mm

15706 32,00€

0.55 - 10 240

390mm 180mm 40mm



51805 17,00€

0.33 4 20 640

225mm 97mm 34mm



x5 50, 75, 100, 152, 227mm

51447 16,00€

0.34 5 20 960

225mm 95mm 34mm



x5 50, 75, 100, 152, 227mm

51448 52,00€

2.38 - 5 270

530mm 120mm 30mm



x5 50, 125, 250, 380, 510mm



54158 38,00€

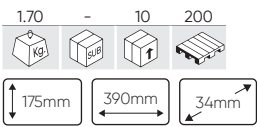

	x7	30mmL	H4, H5, H6, H7, H8, H10, H12
	x5		M5, M6, M8, M10, M12
	x8		T20, T25, T30, T40, T45, T50, T55, T60
	x7	70mmL	H4, H5, H6, H7, H8, H10, H12
	x5		M5, M6, M8, M10, M12
	x8		T20, T25, T30, T40, T45, T50, T55, T60
	x2		1/2", 3/8"

15737 48,50€

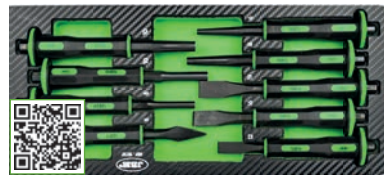
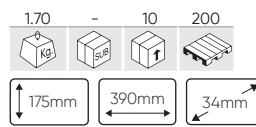

	x3		12x160, 16x175, 19x180mm
	x1		6x180mm
	x3		6x180, 8x180, 10x180mm
	x2		8x180, 10x180mm

15084 68,00€

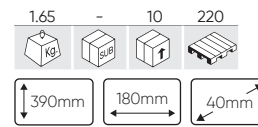

	x2		5/16", 3/8"
	x7		7, 8, 10, 11, 12, 13, 14mm
	x1		10mm
	x1		10mm
	x7		8, 9, 10, 12, 13, 14, 17mm
	x1		T45
	x1		M16
	x1		200mm
	x1		150mm

53979 38,00€

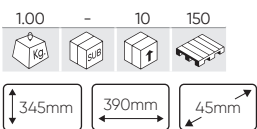

	x8		T10x75, T15x75, T20x100, T25x100, T30x150, T40x150, T45x200, T50x200
--	----	--	--

53980 38,00€

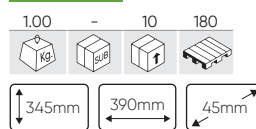

	x8		H2x100, H2.5x100, H3x100, H4x150, H5x150, H6x200, H8x200, H10x200
--	----	--	---

54481 113,00€

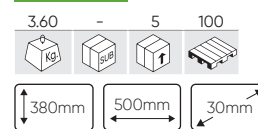

	x7		7, 8, 9, 10, 13, 17, 19mm (465mm)
--	----	--	-----------------------------------

15162 32,50€

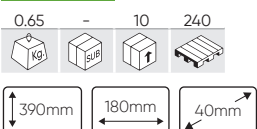

	x4		SL3x75, 4x100, 5.5x125, 6.5x150mm
	x3		PH0x75, 1x80, 2x100mm
	x1		SL3x140mm

54093 441,00€

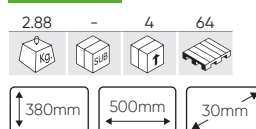

	x10		8, 10, 11, 12, 13, 14, 16, 17, 19, 22mm
	x2		4x100, 5.5x125mmL
	x2		PH1x80, PH2x100mmL
	x6		7x86, 8x99, 10x109, 12x127, 14x141, 17x156mmL
	x1		160mm
	x1		185mm
	x1		
	x1		110mm
	x1		200mm
	x1		125mm



1775 99,00€

2.48 - 1 96

NEW

380mm 500mm 30mm

QR Code

x5	SL3x75, 4x75, 5.5x125, 6.5x150, 8x200		
x3	PH1x100, 2x100, 3x150		
x9	1.5, 2, 2.5, 3, 4, 5, 6, 8, 10mm		
x1	175mm	x1	180mm
x1	240mm	x1	200mm

11994 39,50€

0.77 - 10 233

390mm 180mm 40mm

QR Code

x13	1/4" 4, 4.5, 5, 5.5, 6, 7, 8, 9, 10, 11, 12, 13, 14mm	
x2	1/4" 125, 150mm	
x1		x1
x1		x1

53620 99,00€

3.52 - 4 112

390mm 525mm 30mm

QR Code

x17	6, 7, 8, 9, 10, 11, 12, 13, 14, 15, 16, 17, 18, 19, 20, 21, 22mm
x8	6x7, 8x9, 10x11, 12x13, 14x15, 16x17, 18x19, 20x22mm

11996 54,00€

2.10 - 10 240

175mm 390mm 35mm

QR Code

x10	6x7, 8x9, 10x11, 12x13, 14x15, 16x17, 18x19, 20x22, 24x27, 30x32mm
-----	--

11997 42,00€

1.92 - 10 360

175mm 390mm 35mm

QR Code

x8	6x7, 8x9, 10x11, 12x13, 14x15, 16x17, 18x19, 20x22mm
----	--

11998 59,00€

1.96 - 10 180

175mm 390mm 35mm

QR Code

x17	6, 7, 8, 9, 10, 11, 12, 13, 14, 15, 16, 17, 18, 19, 20, 21, 22mm
-----	--

53671 41,00€

0.85 - 10 520

390mm 180mm 40mm

QR Code

x3	1/4" - 85mm 1/2" - 135mm 3/8" - 102mm
----	---

13668 20,50€

0.61 - 10 300

175mm 390mm 35mm

QR Code

x1	3m	x1	50mm
x1	230mm	x1	250mm

14114 21,00€

0.93 - 10 360

175mm 390mm 35mm

QR Code

x1	10"
x1	10"

10735 22,50€

0.98 - 10 300

175mm 390mm 35mm

QR Code

x5	8"
----	----

51738

850,00€

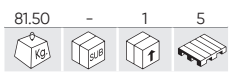

MESA DE TRABALHO COM 3 GAVETAS

Material	Acero/Steel
Gavetas	3
Dimensões da gaveta	348x441x142mm
Capacidade das gavetas	50Kg
Capacidade	1T
Peso	81,50Kg
Dimensões (CxLxA)	2000x640x865mm



REPOSIÇÕES DISPONÍVEIS

51737

699,00€



MESA DE TRABALHO COM 2 GAVETAS

Material	Acero/Steel
Gavetas	2
Medidas das gavetas	348x441x142mm
Capacidade da gaveta grande	50Kg
Capacidade	800Kg
Peso	65,50Kg
Dimensões (CxLxA)	1500x640x865mm



REPOSIÇÕES DISPONÍVEIS

53674

447,00€

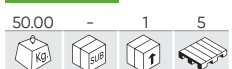

MESA DE TRABALHO COM 1 GAVETA

Material	Acero/Steel
Gavetas	1
Dimensões da gaveta	348x441x142mm
Capacidade das gavetas	50Kg
Capacidade	800Kg
Peso	50,00Kg
Dimensões (CxLxA)	1100x640x865mm



REPOSIÇÕES DISPONÍVEIS



51035

799,00€



BANCADA DE TRABALHO COM 2 GAVETAS E PAINEL FRONTAL



REPOSIÇÕES DISPONÍVEIS

ACOPLAMENTO QUADRADO

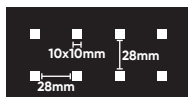

Material	Acero/Steel
Gavetas	2
Dimensões da gaveta	348x441x142mm
Capacidade das gavetas	50Kg
Capacidade	600Kg
Peso	86,50Kg
Dimensões (CxLxA)	1500x640x1550mm

54328

199,00€



BANCADA DE TRABALHO DOBRÁVEL COM PAINEL TRASEIRO



EXPOSITOR SEM FERRAMENTAS

ACOPLAMENTO QUADRADO

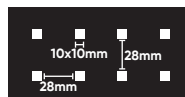

Material	Hierro/Iron, Madera/Wood
Altura de trabalho	800mm
Faixa de trabalho	1200x600mm
Carga máxima	150,00Kg
Peso	30,60Kg
Dimensões dobradas	1200x122x1440mm
Dimensões (CxLxA)	1200x640x1440mm



ACESSÓRIOS PARA ARMARIOS

REF.	DESCRIÇÃO					€
54758	DISPENSADOR DE LUVAS MAGNÉTICAS	1.06	-	12	144	18,00€
54759	SISTEMA ORGANIZADOR DE ENCAIXES MAGNÉTICOS, 38PCS	0.90	-	10	600	25,00€
15068	SUPOORTE DE ROLO DE PAPEL PARA CARRINHO DE FERRAMENTAS	0.65	-	25	1200	16,50€
18379	SUPOORTE PARA ROLO DE PAPEL (CARROS XL)	0.61	-	32	192	15,20€
15069	PORTA DOCUMENTOS PARA CARRO DE FERRAMENTAS	1.65	-	1	80	35,00€
15313	PORTA SPRAYS PARA CARROS DE FERRAMENTAS	0.60	-	1	340	14,00€
14354	PORTA SPRAYS PARA CARROS DE FERRAMENTAS	0.60	-	20	160	14,00€
16359	SUPOORTE DE BROCAS PARA CARRINHO DE FERRAMENTAS	0.20	-	30	-	10,00€
16361	SUPOORTE DE PULVERIZAÇÃO PARA CARRINHO DE FERRAMENTAS	0.84	-	30	240	16,50€
16362	PRATELEIRA PARA CARRINHO DE FERRAMENTAS	0.94	-	30	240	23,00€
16363	SUPOORTE PARA CANETA PARA CARRINHO DE FERRAMENTAS	0.40	-	30	-	14,50€
16344	CAIXOTE DE LIXO MANEJÁVEL DE ESCRITÓRIO	1.58	-	4	72	43,50€
16358	CHAVE DE FENDAS DE GANCHO ESPECIAL	0.45	-	30	660	12,00€
16360	CHAVES DE GANCHO ESPECIAIS PARA CARRINHO DE FERRAMENTAS	0.38	-	30	570	12,00€

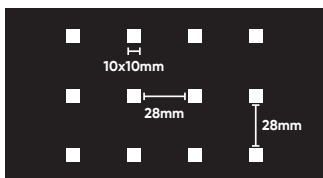

54758



54759



15068



18379



15069

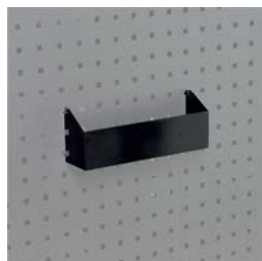

15313

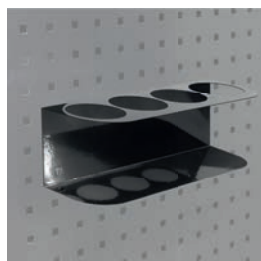

14354



16359



16361



16362



16363

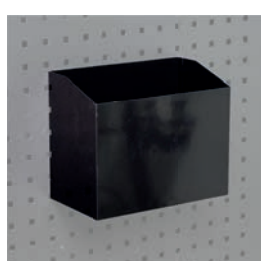

16344



16358



16360



ACESSÓRIOS PARA ARMARIOS

REF.	DESCRIÇÃO					€
16161	SUPORTE DE ROLO DE PAPEL PARA CARRINHO DE FERRAMENTAS	0.55	-	25	-	20,00€
16162	PORTA DOCUMENTOS PARA CARRO DE FERRAMENTAS	1.91	-	4	96	38,50€
16163	PORTA SPRAYS E ACESSÓRIOS PARRA CARROS DE FERRAMENTAS	0.35	-	20	280	12,10€

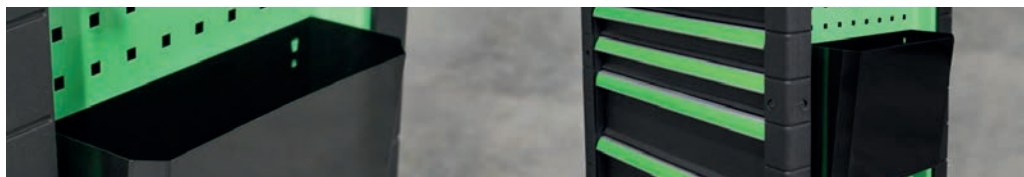
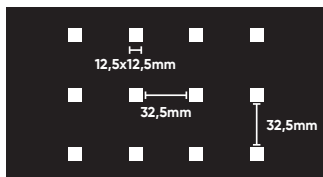

16161

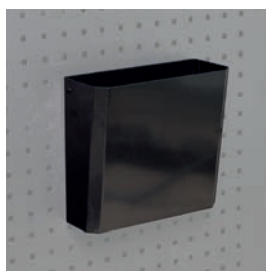

16162

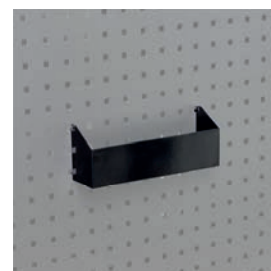

16163

PAINEL PARA FERRAMENTAS

REF.	mm								€
52419	1000x600mm	10x10mm	28mm	Acoplamento quadrado	7.07	-	1	30	90,00€
52420	1500x600mm	10x10mm	28mm	Acoplamento quadrado	10.80	-	4	30	121,00€
52421	2000x600mm	10x10mm	28mm	Acoplamento quadrado	14.00	-	1	38	194,00€

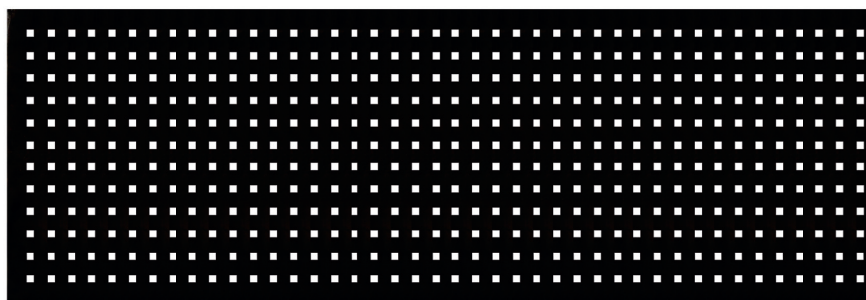

PODE INTERESSAR-LHE...

Para saber qual acessório é compatível com o seu carrinho, é necessário verificar as dimensões das caixas do painel. Pode medi-las diretamente no seu ou confirmar se as que aparecem nesta seção correspondem às referências dos carrinhos listados no catálogo.



GANCHO

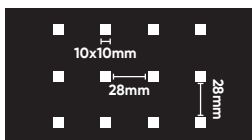

REF.	mm	DESCRIÇÃO					€
16861	50mm	GANCHO 1 BICO 50MM - NERO	0.03	10	100	6000	1,50€
16354	100mm	GANCHO 1 BICO 100MM	0.04	10	100	6600	1,50€
16355	200mm	GANCHO 1 BICO 200MM	0.06	10	100	3000	2,00€
16865	50mm	GANCHO DUPLO 50MM - PRETO	0.07	10	100	5000	2,00€
16356	100mm	GANCHO DUPLO 100 MM	0.08	10	100	-	2,50€
16357	200mm	GANCHO DUPLO 200 MM	0.10	10	100	-	2,80€

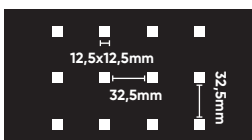

REF.	mm	DESCRIÇÃO					€
51655	31mm	GANCHO DE 2 PONTAS PEQUENAS PARA MESA DE TRABALHO	0.07	10	100	4000	4,70€
51658	82mm	GANCHO DE 2 PONTAS LONGAS PARA MESA DE TRABALHO REF. 52419,52420,52421	0.05	10	100	1500	5,10€
51656	91mm	GANCHO DE PONTA LONGA PARA MESA DE TRABALHO	0.05	10	100	1500	4,20€
51654	95mm	GANCHO DE PONTA FECHADA PARA MESA DE TRABALHO	0.09	10	100	4000	4,20€
52635	200mm	GANCHO DE PONTA FECHADA LONGA PARA MESA DE TRABALHO	0.14	10	50	1500	5,30€
51657	400mm	GANCHO ESPECIAL CHAVES DE FENDA	0.30	10	50	1000	6,50€
51653	148mm	GANCHO ESPECIAL PARA CHAVES	0.28	-	10	840	5,80€

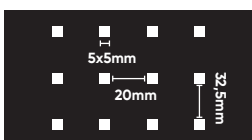

REF.	mm	DESCRIÇÃO					€
51975	30mm	GANCHO CURTO (30MM) PARA PAINEL	0.03	-	100	4000	3,40€
51419	75mm	GANCHO "L" SIMPLES LONGA PARA CARRO	0.03	-	100	2000	3,40€
51420	50mm	GANCHO "J" SIMPLE CURTO PARA CARRO	0.03	-	100	-	3,40€
51422	95mm	GANCHO "L" DUPLO LONGO PARA CARRO	0.05	-	100	1500	3,40€



54784

170,00€

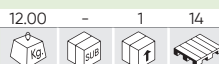

NEW

PRATELEIRA DE ARMAZENAMENTO PARA FERRAMENTAS ELÉTRICAS DE 3 NÍVEIS



Material	Acero/Steel
Gavetas	1
Dimensões da gaveta	449x231x78mm
Capacidade das gavetas	3Kg
Ranuras para ferramentas	5
Compartimentos	3
Peso	12,00Kg
Dimensões (CxLxA)	540x250x340mm



54840

23,00€



NEW

CAPA PADRÃO PARA CARRO DE FERRAMENTAS (770X485X820MM)



Peças	1
Material	Poliéster/ Polyester
Compatível com	54717, 54006, 53904, 54295, 54296, 54297, 53867, 54503
Peso	0,60Kg
Dimensões (CxLxA)	770x485x820mm

54841

27,00€

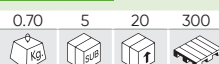

NEW

CAPA XL PARA CARRO DE FERRAMENTAS (1010X485X820MM)



Peças	1
Material	Poliéster/ Polyester
Compatível com	53869, 54690, 53870
Peso	0,70Kg
Dimensões (CxLxA)	1010x485x820mm

NEW CILINDRO COM CHAVE PARA CARRINHOS

REF.	DESCRIÇÃO	kg	Box	Unit	Code	€
16776	601	0.05	-	100	14080	12,00€
16777	602	0.05	-	100	14080	12,00€
16778	603	0.05	-	100	14080	12,00€
16779	604	0.05	-	100	14080	12,00€
16780	605	0.05	-	100	14080	12,00€

REF.	DESCRIÇÃO	kg	Box	Unit	Code	€
18357	1010	0.06	5	100	16000	12,00€
18358	1011	0.06	5	100	16000	12,00€
18359	1012	0.06	5	100	16000	12,00€
18360	1013	0.06	5	100	16000	12,00€
18361	1014	0.06	5	100	16000	12,00€
18362	1015	0.06	5	100	16000	12,00€
18363	1016	0.06	5	100	16000	12,00€
18364	1017	0.06	5	100	16000	12,00€
18365	1018	0.06	5	100	16000	12,00€
18366	1019	0.06	5	100	16000	12,00€



601-605



1010 - 1019

CADEADOS

REF.	mm						€
53403	38mm	Curto	0.15	8	96	3168	6,50€
53405	32mm	Curto	0.10	8	96	3168	5,70€
53406	50mm	Curto	0.30	8	48	1728	8,55€
53407	63mm	Curto	0.35	8	48	3168	13,60€
53408	75mm	Curto	0.76	3	24	840	21,00€
53409	50mm	Longo	0.30	8	48	3168	10,30€



CADEADOS RESISTENTES À ÁGUA

REF.	mm						€
53400	40mm		0.20	8	48	499	6,20€
53401	50mm		0.35	8	48	499	8,00€
53402	65mm		0.05	10	40	960	10,30€



50843

79,00€



BANCO HIDRÁULICO



Material	Acero/Steel, PVC
Capacidade	135Kg
Diâmetro	295mm
Altura máxima	520mm
Altura mínima	390mm
Peso	5,61Kg
Dimensões (CxLxA)	380x380x390mm

54583

89,00€

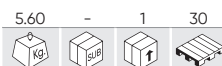

BANQUETA PNEUMÁTICA COM RODÍZIOS



Material	Acero/Steel, PVC
Capacidade	136Kg
Diâmetro	300mm
Altura máxima	540mm
Altura mínima	400mm
Peso	5,60Kg
Dimensões (CxLxA)	470x300x550mm

50844

65,00€



BANCO DE AÇO



Material	Acero/Steel, PVC
Capacidade	115Kg
Altura	380mm
Peso	3,50Kg
Dimensões (CxLxA)	360x375x380mm

55002

98,00€



NEW

BANCO DE AÇO COM BANDEJAS REMOVÍVEIS PARA FERRAMENTAS DE DETAILING



Capacidade	136Kg
Material	Acero/Steel
Altura	397mm
Peso	10,80Kg
Dimensões (CxLxA)	660x397x325mm

52148

65,00€



ESTRADO MECÂNICO PLÁSTICO



Material	PE
Capacidade	150Kg
Peso	6,00Kg
Dimensões (CxLxA)	1020x480x120mm

50808

77,00€

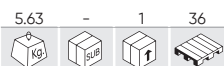

ESTRADO DE MECÂNICO ALMOFADADO DOBRÁVEL

Material	Acero/Steel, PVC
Capacidade dobrada	150Kg
Capacidade	120Kg
Peso	5,63Kg
Dimensões dobradas	500x440x150mm
Dimensões (CxLxA)	930x440x105mm



53211

75,00€

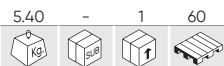

ESTRADO MECÂNICO ALMOFADADO DOBRÁVEL

Material	Acero/Steel, PVC
Capacidade dobrada	120Kg
Capacidade	150Kg
Peso	5,40Kg
Dimensões dobradas	450x420x350mm
Dimensões (CxLxA)	900x420x125mm



52542

109,00€



ESTRADO MECÂNICO ALMOFADADOS DOBRÁVEL

Material	Acero/Steel, PVC
Capacidade dobrada	115Kg
Capacidade	135Kg
Peso	12,70Kg
Dimensões dobradas	650x450x475mm
Dimensões (CxLxA)	1180x420x105mm



BOLSA PARA FERRAMENTAS

REF.	DESCRIÇÃO								€
53702	Pequena	300mm	305mm	190mm	1.00	-	10	150	34,50€
53703	Média	300mm	406mm	190mm	1.40	-	10	120	43,00€
53704	Grande	300mm	508mm	230mm	1.65	-	10	120	44,50€



53702



53703



53704

53782

14,00€



BOLSA PARA FERRAMENTAS ELÉTRICAS - GRANDE

Material	Tela Oxford/Oxford Cloth
Capacidade	36L
Peso	0,65Kg
Dimensões (CxLxA)	500x250x290mm



54080

54,00€

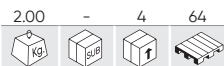

BOLSA DE FERRAMENTAS

Material	Tela Oxford/Oxford Cloth
Capacidade	20L
Peso	2,00Kg
Dimensões (CxLxA)	480x210x340mm



54374

79,00€



SACO DE FERRAMENTAS

Material	Tela Oxford/Oxford cloth 1680D/600D, PVC
Capacidade	41L
Peso	2,10Kg
Dimensões (CxLxA)	360x230x500mm



54804

99,00€



NEW

MOCHILA TROLLEY

Material	Poliéster/Polyester
Capacidade	38L
Compartimentos	27
Peso	2,55Kg
Dimensões (CxLxA)	310x280x500mm



51575

317,00€

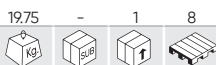

CAIXA DE FERRAMENTAS COM 6 GAVETAS



Material	Acero/Steel
Gavetas	7
Medidas da gaveta superior	650x303x70mm
Medidas da gaveta pequena	170,5x273x48mm
Medidas de gaveta média	570x273x48mm
Dimensões gaveta grande	570x273x74,5mm
Capacidade da gaveta superior	30Kg
Capacidade da gaveta pequena	20Kg
Capacidade da gaveta média	30Kg
Capacidade da gaveta grande	30Kg
Capacidade	100Kg
Peso	19,75Kg
Dimensões (CxLxA)	660x307x377mm

51600

109,00€



CAIXA DE FERRAMENTAS COM 3 GAVETAS FRONTAIS



Material	Acero/Steel
Gavetas	4
Medidas da gaveta superior	530x235x47mm
Dimensões da gaveta	472x205x40mm
Capacidade da gaveta superior	20Kg
Capacidade das gavetas	15Kg
Capacidade	65Kg
Peso	8,45Kg
Dimensões (CxLxA)	537x240x289mm



VER PÁGINA 24

Descubra as caixas de ferramentas que temos disponíveis para si. Veja a vista ampliada de cada uma delas na secção de caixas de ferramentas e escolha a que melhor se adapta às suas necessidades.



CAIXA DE FERRAMENTAS

REF.	DESCRIÇÃO								€
54393	CAIXA DE FERRAMENTAS 75CM	750mm	200mm	220mm	7.70	-	1	15	99,00€
54394	CAIXA DE FERRAMENTAS 53CM	530mm	200mm	220mm	5.70	-	1	22	70,00€
54395	CAIXA DE FERRAMENTAS 45CM	450mm	200mm	220mm	6.20	-	1	24	58,00€
51574	CAIXA DE FERRAMENTAS COM 5 COMPARTIMENTOS	405mm	205mm	205mm	3.39	-	1	31	58,00€



50957

22,00€

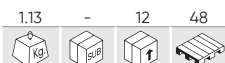

CAIXA 24+2 COMPARTIMENTOS



Peças	Vazio/Empty
Compartimentos	26
Peso	1,13Kg
Dimensões (CxLxA)	540x80x280mm

50959

14,00€

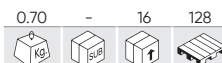

CAIXA 20+1 COMPARTIMENTOS



Peças	Vazio/Empty
Compartimentos	21
Peso	0,70Kg
Dimensões (CxLxA)	360x65x280mm

51050

285,00€



ESTANTERIA COM 47 COMPARTIMENTOS

COMPARTIMENTOS PEQUENOS

Total: 32
Medidas: 16x10x7,5 cm
Medidas da estanteria: 84x16x8 cm
Total estantes: 4

COMPARTIMENTOS GRANDES

Total: 15
Medidas: 24x14.5x13 cm
Medidas da estanteria: 84x14x24 cm
Total estantes: 3



51051

40,00€



ORGANIZADOR DE 5 COMPARTIMENTOS



Caixas inseparáveis

53031

64,00€

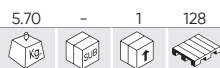

**TORNO DE BANCADA
BASE ROTATIVA 4"**



Material	Hierro/Iron
Abertura	75mm
Comprimento da boca	100mm
Peso	5,70Kg

53032

126,00€



**TORNO DE BANCADA
BASE ROTATIVA 6"**



Material	Hierro/Iron
Abertura	125mm
Comprimento da boca	150mm
Peso	13,71Kg

52869

55,00€



**TORNO DE BANCADA
100MM**



Material	Hierro/Iron
Abertura	75mm
Comprimento da boca	100mm
Peso	4,15Kg

52870

100,00€



**TORNO DE BANCADA
150MM**



Material	Hierro/Iron
Abertura	125mm
Comprimento da boca	150mm
Peso	10,90Kg

52871

258,00€

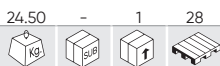

**TORNO DE BANCADA ABERTURA RÁPIDA
BASE ROTATIVA**

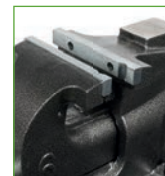

Material	Hierro/Iron
Abertura	254mm
Comprimento da boca	150mm
Peso	24,50Kg
Dimensões (CxLxA)	508x207x244mm

50789

29,00€

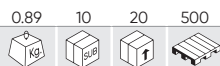

BARRA MAGNÉTICA PARA FERRAMENTAS



Tipo	Imantado/Magnetised
Peso	0,890mm
Comprimento	600mm

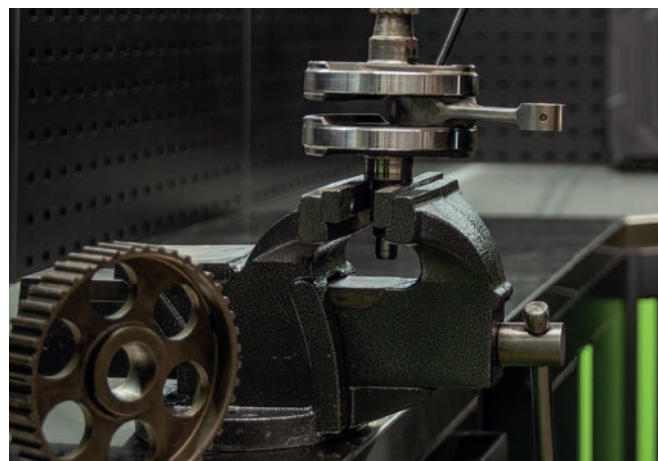

53903

66,00€

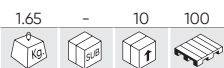

CONJUNTO DE 3 BANDEJAS DE FERRAMENTAS ELÁSTICAS ANTI DERRAPANTE

REF.	DESCRIÇÃO								€
15010	Pequena	137mm	285mm	27mm	0.40	-	20	360	17,90€
15011	Média	202mm	285mm	27mm	0.45	-	20	320	19,40€
15012	Grande	300mm	543mm	27mm	1.05	-	10	120	36,50€



15012



15011



15010

50787

8,00€

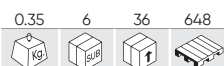

PRATO REDONDO MAGNÉTICO Ø150MM



Material	Acero inoxidable/ Stainless steel
Tipo	Imantado/Magnetized
Peso	0,35Kg
Diâmetro	150mm

50788

14,50€



PRATO RECTÂNGULAR MAGNÉTICO



Material	Acero inoxidable/ Stainless steel
Tipo	Imantado/Magnetized
Peso	0,62Kg
Dimensões (CxX)	139x239mm

52466

11,00€

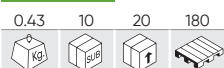

RECIPIENTE MAGNÉTICO



Material	ABS
Tipo	Imantado/Magnetized
Peso	0,43Kg
Diâmetro	150mm

53958

6,50€



CONJUNTO DE 5 ÍMÃS



Capacidade	2,25Kg
Peças	5
Material	Neodímio/Neodymium
Tipo	Imantado/Magnetized
Diâmetro	15mm
Peso	0,05Kg

54682

54,00€

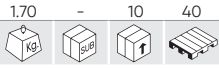

PLATAFORMA MÓVEL DE AJOELHAMENTO



Material	Polipropileno/Polypropylene
Carga máxima	100Kg
Peso	1,7Kg
Dimensões (CxLxA)	500x255x85mm



53192

53,00€

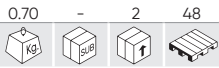

ESTRADO EM ESPUMA



Material	Espuma EVA/EVA foam
Peso	0,70Kg
Dimensões dobradas	420x180x200mm
Dimensões (CxLxA)	420x1200x5440mm

53191

14,80€

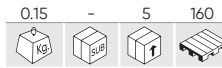

ESTRADO EM ESPUMA



Material	Espuma EVA/EVA foam
Peso	0,15Kg
Dimensões (CxLxA)	480x180x320mm

54805

478,00€

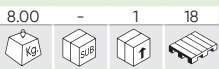

NEW

CONJUNTO DE CANDEIROS DE TECTO HEXAGONAIS

Brilho	83640Lm
Potência	615W
Eficiência	110-120Lm/W
Tensão	185-240V
Tipo de LED	2835
Número de LEDs	12
Temperatura de cor do LED	6500k
Material	Al + PC
Comprimento do cabo	1,5m Enchufe europeu/ EU Plug
Proteção IP	IP45
Peso	8,00Kg
Dimensões (CxLxA)	2435x42x4845mm

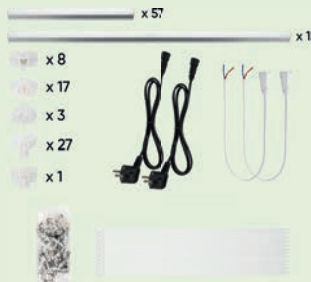

REPOSIÇÕES DISPONÍVEIS

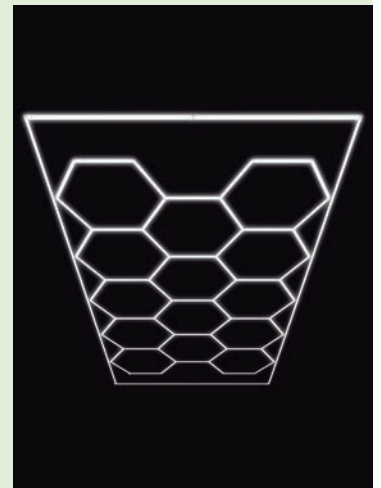

NEW	LADRILHO DE PISO PERFURADO DE PP		mm					€
54906	●	LADRILHO DE PISO PRETO PERFURADO DE PP	400x400x18mm	0.58	-	30	360	6,40€
54907	●	LADRILHO DE PISO CINZENTO PERFURADO DE PP	400x400x18mm	0.58	-	30	360	6,40€
54908	●	LADRILHO DE PISO AMARELO PERFURADO DE PP	400x400x18mm	0.58	-	30	360	6,40€
54909	●	LADRILHO DE PISO VERMELHO PERFURADO DE PP	400x400x18mm	0.58	-	30	360	6,40€
54910	●	LADRILHO DE PISO VERDE PERFURADO DE PP	400x400x18mm	0.58	-	30	360	6,40€

* Preço unitário. Compra mínima: 30 unidades.



ESPECIFICAÇÕES TÉCNICAS

Peças	1
Capacidade	8T/m2
Material	PP
Acabado	Antideslizante/Non-slip
Resistência térmica	-30/+80°C
Resistente aos raios UV	Si/Yes
Dimensões (CxLxA)	400x400x18mm
Peso	0,60Kg

ACESSÓRIOS

PERFIL PARA LADRILHOS

REF.	DESCRIÇÃO					€
18090	● ♂ PERFIL PRETO PARA LADRILHOS DE PP (MACHO)	0.11	20	120	1920	3,00€
18091	● ♂ PERFIL CINZENTO PARA LADRILHOS DE PP (MACHO)	0.11	20	120	1920	3,00€
18092	● ♂ PERFIL AMARELO PARA LADRILHOS DE PP (MACHO)	0.11	20	120	1920	3,00€
18100	● ♀ PERFIL PRETO PARA LADRILHOS DE PP (FÊMEA)	0.12	20	120	1920	3,00€
18101	● ♀ PERFIL CINZENTO PARA LADRILHOS DE PP (FÊMEA)	0.12	20	120	1920	3,00€
18102	● ♀ PERFIL AMARELO PARA LADRILHOS DE PP (FÊMEA)	0.12	20	120	1920	3,00€

* Preço unitário. Compra mínima: 10 unidades.

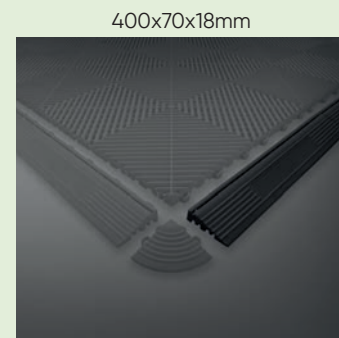

CANTO PARA LADRILHOS

REF.	DESCRIÇÃO					€
18093	● CANTO PRETO PARA LADRILHOS DE PP	0.16	10	450	5400	1,00€
18094	● CANTO CINZENTO PARA LADRILHOS DE PP	0.16	10	450	5400	1,00€
18095	● CANTO AMARELO PARA LADRILHOS DE PP	0.16	10	450	5400	1,00€



NEW LADRILHO DE PVC PARA PISO

REF.	DESCRIÇÃO	mm					€
55044	● LADRILHO DE PVC PRETO PARA PISO	400x400x18mm	1.58	-	20	320	16,00€
55045	● LADRILHO DE PVC CINZENTO PARA PISO	400x400x18mm	1.58	-	20	320	16,00€
55048	● LADRILHO DE PVC AMARELO PARA PISO	400x400x18mm	1.58	-	20	320	16,00€
55047	● LADRILHO DE PVC VERMELHO PARA PISO	400x400x18mm	1.58	-	20	320	16,00€
55046	● LADRILHO DE PVC VERDE PARA PISO	400x400x18mm	1.58	-	20	320	16,00€

* Preço unitário. Compra mínima: 30 unidades.



ESPECIFICAÇÕES TÉCNICAS

Peças	1
Capacidade	15T/m ²
Material	PVC
Acabado	Antideslizante/Non-slip
Resistência térmica	-30/+35°C
Resistente aos raios UV	Si/Yes
Dimensões (CxLxA)	500x500x6mm
Peso	1,60Kg

ACESSÓRIOS

PERFIL PARA LADRILHOS

REF.	DESCRIÇÃO					€
18300	● PERFIL PRETO PARA LADRILHOS DE PVC	0.24	50	100	1600	5,50€
18301	● PERFIL CINZENTO PARA LADRILHOS DE PVC	0.24	50	100	1600	5,50€
18304	● PERFIL AMARELO PARA LADRILHOS DE PVC	0.24	50	100	1600	5,50€

* Preço unitário. Compra mínima: 10 unidades.



400x70x18mm

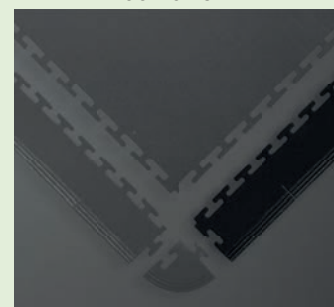

CANTO PARA LADRILHOS

REF.	DESCRIÇÃO					€
18295	● CANTO PRETO PARA LADRILHOS DE PVC	0.03	250	500	8000	2,00€
18296	● CANTO CINZENTO PARA LADRILHOS DE PVC	0.03	250	500	8000	2,00€
18299	● CANTO AMARELO PARA LADRILHOS DE PVC	0.03	250	500	8000	2,00€

70x70x18mm



FERRAMENTAS ELÉTRICAS SEM FIO

20V

- 130 APARAFUSAR
- 134 PERFURAR
- 138 LIXAR/POLIR
- 141 SERRAR
- 144 FERRAMENTAS ESPECIAIS
- 150 FERRAMENTAS DE JARDINAGEM
- 153 BATERIAS / CARREGADORES

12V

- 154 APARAFUSAR
- 155 PERFURAR
- 156 LIXAR/POLIR
- 156 SERRAR
- 156 FERRAMENTAS ESPECIAIS
- 157 BATERIAS / CARREGADORES



CHAVE DE IMPACTO SEM FIO

SEM ESTOJO	60050	60048	60044	60051	60046
	409,00€	366,00€	330,00€	211,00€	174,00€
Medida do quadrado	1"	3/4"	1/2"	1/2"	1/2"
Tensão	20V	20V	20V	20V	20V
Potência	1300W	1000W	1000W	850W	700W
Torque de aperto	1800Nm	1500Nm	1200Nm	850Nm	550Nm
Torque de desaperto	2300Nm	1800Nm	1300Nm	1000Nm	800Nm
Velocidade nominal	1850RPM	1800RPM	1600RPM	2400RPM	2800RPM
Impulsos IPM	2400IPM	2200IPM	2000IPM	2800IPM	3000IPM
Medidas da cabeceira	250mm	215mm	215mm	170mm	140mm
Peso	3.60Kg	3.26Kg	3.25Kg	2.20Kg	1.50Kg
Caixa	4	4	5	4	4
Palete	80	80	72	150	224



- NOVA TECNOLOGIA**
 Motor brushless X-Torq de nova geração para realizar com sucesso trabalhos profissionais.
- ALTO DESEMPENHO**
 Possui cinco modos de trabalho para apertar e soltar parafusos de forma fácil e segura.
- MICROPROCESSADOR INTELIGENTE**
 Protege a ferramenta contra sobrecargas e superaquecimento em altas temperaturas.

CHAVE DE IMPACTO SEM FIO

COM ESTOJO	60050C	60048C	60044C	60051C	60046C
	564,00€	560,00€	485,00€	372,50€	339,00€
Medida do quadrado	1"	3/4"	1/2"	1/2"	1/2"
Tensão	20V	20V	20V	20V	20V
Potência	1300W	1000W	1000W	850W	700W
Torque de aperto	1800Nm	1500Nm	1200Nm	850Nm	550Nm
Torque de desaperto	2300Nm	1800Nm	1300Nm	1000Nm	800Nm
Velocidade nominal	1850RPM	1800RPM	1600RPM	2400RPM	2800RPM
Impulsos IPM	2400IPM	2200IPM	2000IPM	2800IPM	3000IPM
Medidas da cabeceira	250mm	215mm	215mm	170mm	140mm
Inclui bateria	60015 (6.0Ah)	60015 (6.0Ah)	60013 (4.0Ah)	60013 (4.0Ah)	60013 (4.0Ah)
Inclui carregador	60016 (20V-4A)	60016 (20V-4A)	60016 (20V-4A)	60016 (20V-4A)	60016 (20V-4A)
Peso	7.20Kg	7.15Kg	7.05Kg	7.05Kg	5.00Kg
Caixa	4	4	4	4	4
Palete	40	40	40	40	40



60050C



60048C



60044C



60051C



60046C



ORGANIZE E PROTEJA AS SUAS FERRAMENTAS COM OS NOSSOS ESTOJOS

- CHAVE DE IMPACTO
- BATERIA
- CARREGADOR

É possível adicionar outra bateria no estojo.



54863

499,00€

15.00 - 1 30



NEW

MALA DE FERRAMENTAS COM CHAVE DE IMPACTO SEM ESCOVAS A BATERIA 800NM

Peças	152
Medida do quadrado	1/2", 3/8", 1/4"
Acabado	Cincado/Zinc Finish
Perfil	Hexagonal, Torx
Material	Cr-V
Inclui	60046, 60013, 60066
Peso	15,00Kg
Dimensões (CxLxA)	580x420x150mm



REPOSIÇÕES DISPONÍVEIS



60052C

287,00€

4.70 - 4 32



APARAFUSADORA DE IMPACTO A BATERIA 1/4" 230 NM COM MALA

Medida do quadrado	1/4"
Tensão	20V
Potência	500W
Torque de aperto	230Nm
Velocidade nominal	1200, 1900, 2500, 3200RPM
Impulsos IPM	1400, 2200, 3000, 4000
Velocidades	4
LED	Si/Yes
Inclui	60052, 60013, 60016
Compatível com	60013, 60015, 60016, 60017
Peso	4,70Kg
Dimensões (CxLxA)	110x70x205mm



REPOSIÇÕES DISPONÍVEIS



CONTÉM

REF.	DESCRIÇÃO					€
60052	APARAFUSADORA DE IMPACTO A BATERIA 1/4" - 230 NM	1.30	-	5	-	139,00€
60013	4.0 AH BATERIA DE LITIO	0.75	-	5	700	80,00€
60016	CARREGADOR 20V - 4A	0.80	-	5	210	49,00€

54586

5,00€

0.41 10 100 3200



CONJUNTO DE 3 ADAPTADORES DE CHAVES DE CAIXA COM PONTA HEXAGONAL

x1	1/2"	73mm
x1	3/8"	67mm
x1	1/4"	65mm



60064C

1.645,00€

23.55	-	1	11

NEW

CHAVE DE IMPACTO BRUSHLESS A BATERIA 1" 4000NM COM MALETA



REPOSIÇÕES
DISPONÍVEIS



VIDEO
TUTORIAL

Medida do quadrado	1"	Velocidades	950, 750, 550RPM
Tensão nominal	2x20V DC	LED	Si/Yes
Potência	2600W	Compatível com	60013, 60015
Torque de aperto	3000, 2200, 1600Nm	Peso	22,70Kg
Torque de desaperto	4000Nm	Dimensões (CxLxA)	860x200x340mm
Impulsos IPM	1300, 1000, 600	Inclui	60015 (x2), 60016 (x1)

CONTÉM

REF.	DESCRIÇÃO					€
60064	CHAVE DE IMPACTO BRUSHLESS A BATERIA 1" 4000NM	16.45	-	1	18	1.444,00€
x2 60015	6.0 AH BATERIA DE LITIO	1.00	-	5	630	138,00€
60016	CARREGADOR 20V - 4A	0.80	-	5	210	49,00€



60023C

349,00€

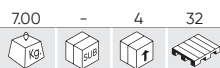

MARTELO PERCUTOR BRUSHLESS COM MALETA

Tensão	20V
Potência	500W
Velocidade nominal	1350RPM
Taxa de impacto	4750BPM
Força de impacto	2,2J
Ø de perfuração em concreto	22mm
Ø de perfuração em aço	13mm
Ø perfuração em madeira	28mm
amanho do mandril	Ø15mm
Velocidades	4
LED	Si/Yes
Inclui	60023, 60013, 60016
Compatível com	60012, 60013, 60015, 60016, 60017
Peso	7,00Kg
Dimensões (CxLxA)	286x75x218mm



REPOSIÇÕES DISPONÍVEIS



CONTÉM

REF.	DESCRIÇÃO				€	
60023	MARTELO PERCUTOR BRUSHLESS	3.10	-	5	120	212,00€
60013	4.0 AH BATERIA DE LITIO	0.75	-	5	700	80,00€
60016	CARREGADOR 20V - 4A	0.80	-	5	210	49,00€

FORMÃO SDS-PLUS

REF.	mm				€	
14837	14x250mm	0.25	10	100	-	3,30€
14838	20x250mm	0.25	10	100	-	3,50€
14839	40x250mm	0.29	10	50	-	4,70€
14840	250mm	0.27	10	50	-	3,50€



53850

16,00€

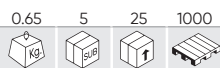

CONJUNTO DE BROCAS PARA BERBEQUIM PERCUTOR

- Ø 5x110mm
- Ø 6x110mm
- Ø 6x160mm
- Ø 8x110mm
- Ø 8x160mm
- Ø 10x160mm
- Ø 12x160mm



REPOSIÇÕES DISPONÍVEIS

14841

2,58€

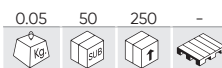

ADAPTADOR SDS-PLUS PARA CARTUCHO DE PERFURAÇÃO DE 1/2 "



Medidas	1/2"-75mm
Diâmetro	10mm
Material	Acero/Steel

14842

9,50€

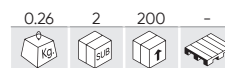

PORTA-BROCAS DE MUDANÇA RÁPIDA 2-13 MM 1/2 "-20 UNF (ROSCA FINA UNIFICADA)



Medidas	1/2"-60mm
Diâmetro	4mm
Material	Acero/Steel

60047C

318,00€

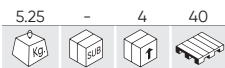

FURADEIRA PERCUTORA SEM FIO DE 2 VELOCIDADES COM CAIXA

Tensão	20V
Potência	900W
Binário máximo	150Nm
Velocidade nominal	500, 2200RPM
Taxa de impacto	35000BPM
Ø de perfuração em concreto	13mm
Ø de perfuração em aço	13mm
Ø perfuração em madeira	40mm
amanho do mandril	Ø13mm
Velocidades	2
LED	Si/Yes
Inclui	60047, 60013, 60016
Compatível com	60013, 60015, 60016, 60017
Peso	4,90Kg
Dimensões (CxLxA)	420x105x340mm



REPOSIÇÕES DISPONÍVEIS



CONTÉM

REF.	DESCRIÇÃO					€
60047	BROCA DE MARTELO SEM FIO DE 2 VELOCIDADES	1.80	-	4	90	237,50€
60013	4.0 AH BATERIA DE LITIO	0.75	-	5	700	80,00€
60016	CARREGADOR 20V - 4A	0.80	-	5	210	49,00€



CONJUNTO DE BROCAS HELICOIDAIS

REF.	DESCRIÇÃO	PCS	MATERIAL	BROCAS					€
53851	CONJUNTO DE BROCAS ESPIRAIS HSS 4241, 1-10 MM, PRETO.	170PCS	HSS-R 4241	1-10mm	3.80	-	4	192	89,00€
53855	CONJUNTO DE BROCAS ESPIRAIS HSS 4241, 1-13 MM, PRETO.	25PCS	HSS-R 4241	1-13mm	1.19	5	10	192	27,50€
53853	CONJUNTO DE BROCAS HSS 4241, 1-10 MM, PRETO.	19PCS	HSS-R 4241	1-10mm	0.58	5	20	192	14,60€
53852	BROCA ESPIRAL SET HSS 4341, 1-10 MM	170PCS	HSS-G 4341	1-10mm	4.20	-	4	192	219,00€
53856	CONJUNTO DE BROCAS ESPIRAIS HSS 4341, 1-13 MM	25PCS	HSS-G 4341	1-13mm	1.32	5	10	550	67,00€
53854	CONJUNTO DE BROCAS ESPIRAIS HSS 4341, 1-10 MM	19PCS	HSS-G 4341	1-10mm	0.63	5	20	192	28,00€
54348	CONJUNTO DE BROCAS HELICOIDAIS 1-10MM HSS-CO5 COBALTO	170PCS	HSS-CO5	1-10mm	4.20	2	4	160	291,00€
54314	CONJUNTO DE BROCAS HELICOIDAIS EM COBALTO 1-13MM	25PCS	HSS-CO5	1-13mm	1.32	5	10	450	82,00€
54313	CONJUNTO DE BROCAS HELICOIDAIS EM COBALTO 1-13MM	19PCS	HSS-CO5	1-10mm	0.60	5	10	1000	43,00€

53851



REPOSIÇÕES DISPONÍVEIS



53855



REPOSIÇÕES DISPONÍVEIS



53853



REPOSIÇÕES DISPONÍVEIS



53852



REPOSIÇÕES DISPONÍVEIS



53856



REPOSIÇÕES DISPONÍVEIS



53854



REPOSIÇÕES DISPONÍVEIS



54348



REPOSIÇÕES DISPONÍVEIS



54314



REPOSIÇÕES DISPONÍVEIS



54313



REPOSIÇÕES DISPONÍVEIS

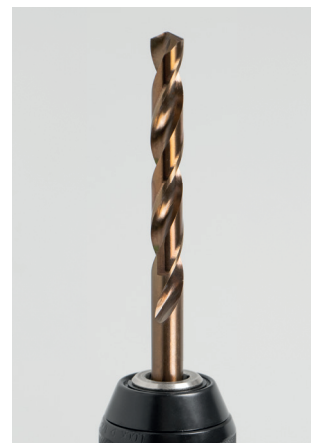

53860

3,90€

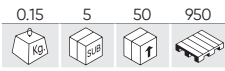

CONJUNTO DE 5 BROCAS PARA ALVENARIA 4-10 MM

- ø 4x75mm
- ø 5x80mm
- ø 6x100mm
- ø 8x120mm
- ø 10x120mm



REPOSIÇÕES DISPONÍVEIS

53861

5,80€

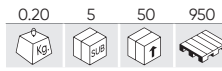

CONJUNTO DE 8 BROCAS PARA ALVENARIA 3-10MM

- ø 3x60mm
- ø 4x75mm
- ø 5x80mm
- ø 6x100mm
- ø 7x100mm
- ø 8x120mm
- ø 9x120mm
- ø 10x120mm



REPOSIÇÕES DISPONÍVEIS

53859

69,00€

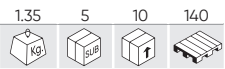

CONJUNTO BROCAS CRANEADAS COM ADAPTADORES



REPOSIÇÕES DISPONÍVEIS

- 22, 29, 35, 44, 51, 68mm
- 14-30, 32-152mm



54346

12,80€

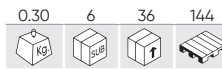

CONJUNTO DE 3 ESCOVAS DE LIMPEZA PARA BERBEQUIM



- 1/4" PP ø 88mm
- 1/4" PP ø 100mm
- 1/4" PP ø 50mm



53857

29,00€

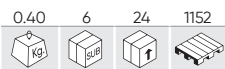

CONJUNTO DE PONTAS DE IMPACTO COM ADAPTADOR RÁPIDO S2



EM EXPOSITOR DE 6 UDS

	x9	PH	25mm	1x3, 2x3, 3x3
	x9	PZ	25mm	1x3, 2x3, 3x3
	x4	H	25mm	3, 4, 5, 6
	x6	SL	25mm	4x2, 5x2, 6x2
	x14	TX	25mm	10x2, 15x2, 20x2, 25x2, 27x2, 30x2, 40x2
	x7	T	25mm	10, 15, 20, 25, 27, 30, 40
	x7		65mm	PH2, PH3, PZ1, PZ2, T20, T25, SL6
	x1		60mm	

53858

31,00€

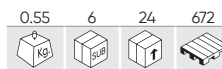

CONJUNTO DE PONTAS COM ADAPTADORES S2- REVESTIMENTO PRETO



EM EXPOSITOR DE 6 UDS

	x4	PH	25mm	1, 2x2, 3
	x3	PZ	25mm	1, 2, 3
	x4	H	25mm	3, 4, 5, 6
	x4	SL	25mm	3, 4, 5, 6
	x6	TX	25mm	10, 15, 20, 25, 30, 40
	x6		75mm	T15, T20, T25, PH2, PZ2, SL5
	x4		48mm	6, 7, 8, 10mm
	x1		60mm	
	x1		80mm	

60054C

329,00€



REBARBADORA ÂNGULAR BRUSHLESS 115MM COM CAIXA

Tensão	20V
Potência	1115W
Velocidade nominal	8000RPM
Diâmetro do disco	115mm
Diâmetro do eixo	M14
Vibrações por minuto	0,8m/s2
LED	No
Inclui	60054, 60013, 60016
Compatível com	60012, 60013, 60015, 60016, 60017
Peso	5,50Kg
Dimensões (CxLxA)	318x137x105mm



REPOSIÇÕES DISPONÍVEIS

CONTÉM

REF.	DESCRIÇÃO					€
60054	REBARBADORA ÂNGULAR BRUSHLESS 115MM	1.78	-	4	120	171,00€
60013	4.0 AH BATERIA DE LITIO	0.75	-	5	700	80,00€
60016	CARREGADOR 20V - 4A	0.80	-	5	210	49,00€

DISCO DE CORTE

PARA METAL

REF.	m/s	RPM								€	
14893	T42	80m/s	13300RPM	2.5mm	115mm	22.23mm	0.05	50	200	-	1,00€
14895	T27	80m/s	13300RPM	6mm	115mm	22.23mm	0.15	25	100	-	2,00€



PARA AÇO INOXIDÁVEL

REF.	m/s	RPM								€	
14897	T41	80m/s	13300RPM	1mm	115mm	22.23mm	0.01	50	400	30000	1,00€
14899	T41	80m/s	13300RPM	1.6mm	115mm	22.23mm	0.03	50	400	-	1,00€



15014

20,00€

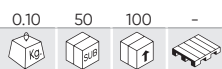

PORCA DE REMOÇÃO RÁPIDA M14 PARA REBARBADORA

M14	115-230mm
-----	-----------



60049C

329,00€

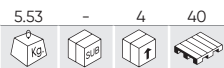

REBARBADORA ÂNGULAR BRUSHLESS 125MM COM CAIXA

Tensão	20V
Potência	1115W
Velocidade nominal	8000RPM
Diâmetro do disco	125mm
Diâmetro do eixo	M14
Vibrações por minuto	0,8m/s2
Inclui	60049, 60013, 60016
LED	No
Compatível com	60012, 60013, 60015, 60016, 60017
Peso	2,55Kg
Dimensões (CxLxA)	318x137x105,5mm



REPOSIÇÕES DISPONÍVEIS

CONTÉM

REF.	DESCRIÇÃO					€
60049	REBARBADORA ANGULAR A BATERIA - 125MM	1.78	-	4	156	175,00€
60013	4.0 AH BATERIA DE LITIO	0.75	-	5	700	80,00€
60016	CARREGADOR 20V - 4A	0.80	-	5	210	49,00€

DISCO DE CORTE

PARA METAL

REF.	m/s	RPM								€
14894	T42 80m/s	12200RPM	2.5mm	125mm	22.23mm	0.05	50	200	-	1,20€
14896	T27 80m/s	12200RPM	6mm	125mm	22.23mm	0.78	25	100	-	2,10€



PARA AÇO INOXIDÁVEL

REF.	m/s	RPM								€
14898	T41 80m/s	12200RPM	1mm	125mm	22.23mm	0.03	50	400	30000	0,98€
14900	T41 80m/s	12200RPM	1.6mm	125mm	22.23mm	0.04	50	400	-	0,98€



15014

20,00€

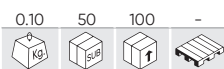

PORCA DE REMOÇÃO RÁPIDA M14 PARA REBARBADORA

M14 115-230mm



60053C

549,00€



KIT DE REBARBADORA ANGULAR E MARTELO PERFURADOR A BATERIA COM MALA DE TRANSPORTE



CONTÉM

REF.	DESCRIÇÃO					€
60047	BROCA DE MARTELO SEM FIO DE 2 VELOCIDADES	1.80	-	4	90	237,50€
60049	REBARBADORA ANGULAR A BATERIA - 125MM	1.78	-	4	156	175,00€
60013	4.0 AH BATERIA DE LITIO	0.75	-	5	700	80,00€
60016	CARREGADOR 20V - 4A	0.80	-	5	210	49,00€

60009C

335,00€



POLIDOR COM MOTOR BRUSHLESS COM CAIXA

Tensão	20V
Velocidade nominal	800-2400RPM
Diâmetro do disco	180mm
Diâmetro do eixo	M14
Vibrações por minuto	89m/s2
LED	No
Inclui	60009, 60013, 60017
Compatível com	60012, 60013, 60015, 60016, 60017
Peso	5,69Kg
Dimensões (CxLxA)	480x175x411mm



REPOSIÇÕES DISPONÍVEIS

CONTÉM

REF.	DESCRIÇÃO					€
60009	POLIDOR COM MOTOR BRUSHLESS	2.65	-	4	70	183,00€
60013	4.0 AH BATERIA DE LITIO	0.75	-	5	700	80,00€
60016	CARREGADOR 20V - 4A	0.80	-	5	210	49,00€

60033

104,00€

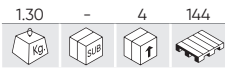

LIXADORA BRUSHLESS



REPOSIÇÕES DISPONÍVEIS

Tensão	20V
Velocidade nominal	10000RPM
Diâmetro do disco	150mm
LED	No
Compatível com	60012, 60013, 60015, 60016, 60017
Peso	1,30Kg
Dimensões (CxLxA)	210x150x150mm

60020

175,00€



PLAINA BRUSHLESS



REPOSIÇÕES DISPONÍVEIS

Tensão	20V
Velocidade nominal	16000RPM
Largura de corte	82mm
Profundidade de corte ajustável	0-2mm
Profundidade de rebaixo ajustável	0-10,5mm
LED	No
Compatível com	60012, 60013, 60015, 60016, 60017
Peso	3,15Kg
Dimensões (CxLxA)	285x150x180mm

60019

178,00€

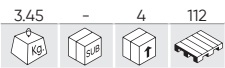

SERRA SABRE COM MOTOR BRUSHLESS

Tensão	20V
Velocidade nominal	3000RPM
Capacidade máxima de corte	150mm Madera/Wood, 10mm Acero/Steel
Comprimento do curso de corte	28mm
LED	No
Compatível com	60012, 60013, 60015, 60016, 60017
Peso	3,45Kg
Dimensões (CxLxA)	440x160x160mm



REPOSIÇÕES DISPONÍVEIS

LÂMINAS DE SERRA

REF.	CORTE	PARA	€
14994	6TPI 150mm	Para madeira	3,50€
14995	24TPI 10mm	Para metal	8,00€



14994



14995



60010C

299,00€



SERRA TICO-TICO BRUSHLESS COM CAIXA

Tensão	20V
Velocidade sem carga	2600SPM
Capacidade máxima de corte	135mm Madera/Wood, 8mm Acero/Steel
Comprimento do curso de corte	26mm
LED	Si/yes
Inclui	60010, 60013, 60016
Compatível com	60012, 60013, 60015, 60016, 60017
Peso	6,00Kg
Dimensões (CxLxA)	230x80x210mm



REPOSIÇÕES DISPONÍVEIS



CONTÉM

REF.	DESCRIÇÃO					€
60010	SERRA TICO-TICO BRUSHLESS	2.80	-	4	144	170,00€
60013	4.0 AH BATERIA DE LITIO	0.75	-	5	700	80,00€
60016	CARREGADOR 20V - 4A	0.80	-	5	210	49,00€

LÂMINAS DE SERRA

REF.	CORTE		PARA					€
14991	T244D 100mm	100mm	Para madeira	0.05	20	200	7200	2,00€
14993	T118A 8mm	76mm	Para metal	0.05	20	200	7200	5,00€



14991



14993

60011

175,00€

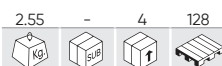

SERRA CIRCULAR COM MOTOR BRUSHLESS

Tensão	20V
Velocidade nominal	4000RPM
Diâmetro do disco	115mm
Profundidade máxima de corte	42,80mm, 0°/28mm, 45°
LED	No
Compatível com	60012, 60013, 60015, 60016, 60017
Peso	2,55Kg
Dimensões (CxLxA)	390x75x120mm



REPOSIÇÕES DISPONÍVEIS



SERRA CIRCULAR

REF.	RPM			PARA					€
14986	T24 7000RPM	115mm	10mm	Para madeira	0.10	20	100	3600	4,00€
14989	T24 7000RPM	115mm	10mm	Para metal	0.10	20	100	3600	6,00€



60007C

329,00€

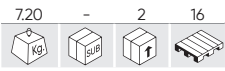

SERRA CIRCULAR COM MOTOR BRUSHLESS COM CAIXA

Tensão	20V
Velocidade nominal	4300RPM
Diâmetro do disco	165mm
Profundidade máxima de corte	55mm, 90° / 35mm, 45°
Inclui	60007, 60013, 60016
LED	Si/Yes
Compatível com	60012, 60013, 60015, 60016, 60017
Peso	7,20Kg
Dimensões (CxLxA)	270x170x290mm



REPOSIÇÕES DISPONÍVEIS



CONTÉM

REF.	DESCRIÇÃO					€
60007	SERRA CIRCULAR COM MOTOR BRUSHLESS	3.75	-	4	60	170,00€
60013	4.0 AH BATERIA DE LITIO	0.75	-	5	700	80,00€
60016	CARREGADOR 20V - 4A	0.80	-	5	210	49,00€

SERRA CIRCULAR

REF.	RPM			PARA					€
14985	T24 7000RPM	165mm	20mm	Para madeira	0.25	20	40	2400	6,00€
14988	T24 7000RPM	165mm	20mm	Para metal	0.25	20	40	2400	8,00€



60022

470,00€

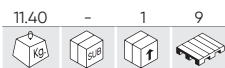

SERRA DE ESQUADRIA MOTOR BRUSHLESS

Tensão	20V
Velocidade nominal	3500RPM
Diâmetro do disco	185mm
Profundidade máxima de corte	152-205mm/38-50mm, 45-90°
LED	LÁSER/LASER
Compatível com	60012, 60013, 60015, 60016, 60017
Peso	11,40Kg
Dimensões (CxLxA)	580x490x320mm



REPOSIÇÕES DISPONÍVEIS



SERRA CIRCULAR

REF.	RPM			PARA					€
14987	T40 7000RPM	185mm	25.4mm	Para madeira	0.30	20	40	2200	8,50€
14990	T40 7000RPM	185mm	25.4mm	Para metal	0.30	20	40	2200	10,50€



60032C

266,00€



PISTOLA PARA SILICONE A BATERIA COM CAIXA

Tensão	20V
Força máxima de empurrão	2500N
Velocidade de avanço	0,5-8mm/s (30-480mm/min)
Capacidade do cartucho	300ml
Velocidade	Ajustable/Adjustable
Inclui	60032, 60013, 60016
LED	Si/Yes
Compatível com	60012, 60013, 60015, 60016, 60017
Peso	4,96Kg
Dimensões (CxLxA)	500x130x400mm



REPOSIÇÕES DISPONÍVEIS

CONTÉM

REF.	DESCRIÇÃO					€
60032	PISTOLA PARA SILICONE A BATERIA	1,95	-	4	80	123,00€
60013	4.0 AH BATERIA DE LITIO	0,75	-	5	700	80,00€
60016	CARREGADOR 20V - 4A	0,80	-	5	210	49,00€

60038C

411,00€



PISTOLA DE GRAXA A BATERIA COM MALETA

Tensão	20V
Pressão máxima	620BAR
Volume/vazão	200g/min
Capacidade do cartucho	420g
Capacidade de graxa a granel	600g
Capacidade de graxa a granel	Hasta/Up toNLGI #2
Comprimento	760mm
Modos de carregamento	Granel/Bulk, Cartucho/Cartridge, Succión/Suction
Inclui	60038, 60013, 60016
LED	Si/Yes
Compatível com	60012, 60013, 60015, 60016, 60017
Peso	7,30Kg
Dimensões (CxLxA)	400x90x270mm



REPOSIÇÕES DISPONÍVEIS

CONTÉM

REF.	DESCRIÇÃO					€
60038	PISTOLA DE GRAXA A BATERIA	3,90	-	4	32	255,00€
60013	4.0 AH BATERIA DE LITIO	0,75	-	5	700	80,00€
60016	CARREGADOR 20V - 4A	0,80	-	5	210	49,00€



60003C

250,00€

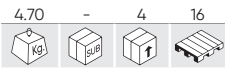

BOMBA DE COMPRESSOR DE AR ELÉTRICO COM CAIXA

Tensão	12-20V
Fluxo de ar	12-380L/min
Pressão de ar máxima	160PSI/11BAR/1100KPA
Comprimento da mangueira de alta pressão	760mm
Comprimento da mangueira de alta capacidade	460mm
Inclui	60003, 60013, 60016
LED	Si/Yes
Compatível com	60012, 60013, 60015, 60016, 60017
Peso	4,70Kg
Dimensões (CxLxA)	240x210x130mm



CONTÉM

REF.	DESCRIÇÃO					€
60003	COMPRESSOR DE AR A BATERIA	1.85	-	4	100	121,00€
60013	4.0 AH BATERIA DE LITIO	0.75	-	5	700	80,00€
60016	CARREGADOR 20V - 4A	0.80	-	5	210	49,00€

60037C

348,00€

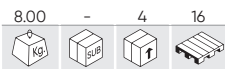

GRAMPEADOR ELÉTRICO COM CAIXA

Tensão	20V
Capacidade	100 Clavos/Nails
Inclui	60037, 60013, 60016
LED	No
Compatível com	60012, 60013, 60015, 60016, 60017
Peso	8,00Kg
Dimensões (CxLxA)	292x94x259mm



CONTÉM

REF.	DESCRIÇÃO					€
60037	GRAMPEADOR ELÉTRICO	3.60	-	4	128	222,00€
60013	4.0 AH BATERIA DE LITIO	0.75	-	5	700	80,00€
60016	CARREGADOR 20V - 4A	0.80	-	5	210	49,00€

CONJUNTO DE GRAMPOS SEM CABEÇA

REF.	mm					€
54008	25x6mm	0.45	-	40	4000	4,10€
54010	32x6mm	0.55	-	40	4000	5,10€
54011	38x6mm	0.65	-	40	4000	6,00€



CONJUNTO DE PREGOS SEM CABEÇA

REF.	mm					€
53999	25x1.25mm	0.20	-	50	5000	2,10€
54000	30x1.25mm	0.25	-	50	5000	2,50€
54002	38x1.25mm	0.30	-	50	5000	3,05€



60041

77,00€



MULTIFERRAMENTA



REPOSIÇÕES DISPONÍVEIS

Tensão	20V
Velocidade nominal	5000, 19000RPM
Velocidades	6
Angulo de oscilação	4,2°
LED	No
Compatível com	60012, 60013, 60015, 60016, 60017
Peso	1,60Kg
Dimensões (CxLxA)	290x75x85mm



LÂMINAS DE SERRA

REF.	mm	PARA					€
15680	20mm	PARA MADEIRA MACIÇA, MADEIRA ABRASIVA E METAIS	0.02	40	240	30720	4,70€
15682	35mm	PARA MADEIRA MACIÇA, MADEIRA ABRASIVA E METAIS	0.05	40	240	30720	4,70€
15683	35mm	PARA MADEIRA	0.01	40	240	30720	2,50€
15684	64mm	PARA FERRO, AÇO, TELHA, TIJOLO E VIDRO	0.02	20	120	8400	7,70€
15685	80mm	PARA MADEIRA MACIÇA, MADEIRA ABRASIVA E METAIS	0.02	40	240	30720	9,50€
15686	88mm	PARA MADEIRA	0.05	20	120	8400	3,70€



OUTROS

REF.	DESCRIÇÃO					€
15687	RASPADOR 50X72MM (REF. 60041)	0.10	40	240	30720	2,50€
15688	PACOTE DE 20 FOLHAS DE LIXAGEM 80X80X80MM - TAMANHO DO GRÃO 60/80/100/120/240 (REF.60041)	0.05	10	100	3600	5,30€
15689	LIXEIRA 79X79X79MM (REF. 60041)	0.05	10	100	3600	4,00€



60001

88,00€

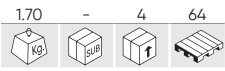

ASPIRADOR PORTÁTIL SEM FIO

Tensão	20V
Potência	3,8KPA
Capacidade do tanque	500ml
LED	No
Compatível com	60012, 60013, 60015, 60016, 60017
Peso	1,70Kg
Dimensões (CxLxA)	410x100x140mm



REPOSIÇÕES DISPONÍVEIS

ACESSÓRIOS

REF.	DESCRIÇÃO					€
14950	A TUBO DE EXTENSÃO PARA REF. 60001	0.08	5	10	-	6,50€
14951	B BOCAL DE FENDA PARA REF. 60001	0.01	-	10	-	9,50€
14952	C BOCAL DE CHÃO REF. 60001	0.15	-	5	-	19,00€
14953	D ESCOVA PARA REF. 60001	0.05	-	10	-	8,50€

60043C

252,00€

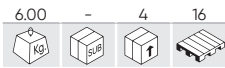

PISTOLA DE PINTURA SEM FIO COM CAIXA

Tensão	20V
Potência	280W
Capacidade do tanque	900ml
Diâmetro do bocal	2,5mm
Distância de pulverização	200mm
Capacidade de pulverização	700ml/min
Inclui	60043, 60013, 60017
LED	No
Compatível com	60012, 60013, 60015, 60016, 60017
Peso	6,00Kg
Dimensões (CxLxA)	350x120x300mm



VIDEO TUTORIAL



REPOSIÇÕES DISPONÍVEIS

CONTÉM

REF.	DESCRIÇÃO					€
60043	PISTOLA DE PINTURA SEM FIO	1.70	-	3	90	123,00€
60013	4.0 AH BATERIA DE LITIO	0.75	-	5	700	80,00€
60016	CARREGADOR 20V - 4A	0.80	-	5	210	49,00€



60071

140,00€

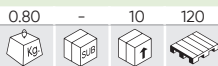

NEW

SOPRADOR DE AR A BATERIA PARA SECAGEM DE VEÍCULOS



Tensão	20V
Fluxo de ar	55m/s
RPM (rotações por minuto)	22500-35000
Taxa de fluxo de ar	10,4CFM (294L/min)
Diâmetro	2,5"
Compatível com	60013, 60015
Peso	0,80Kg
Dimensões (CxLxA)	168x116x255mm

60004

79,00€



FOCO DE ILUMINAÇÃO LED FĂRĂ FIR

Tensão	20V
Potência	1200-2400Lm
Modos de iluminação	2
LED	Si/Yes
Compatível com	60012, 60013, 60015, 60016, 60017
Peso	1,45Kg
Dimensões (CxLxA)	215x175x200mm



15049



REPOSIÇÕES DISPONÍVEIS

ACESSÓRIOS

REF.	DESCRIÇÃO					€
15049	TRIPODE PARA FAROL DE TRABALHO LED (REF. 60004)	2.10	-	4	120	37,40€

60042

106,00€



PISTOLA DE AR QUENTE A BATERIA



REPOSIÇÕES DISPONÍVEIS

Tensão	20V
Potência	80W
Temperatura de saída	550°C
Diâmetro do bocal	34mm
Fluxo de ar	200L/min
LED	Si/Yes
Compatível com	60012, 60013, 60015, 60016, 60017
Peso	1,00Kg
Dimensões (CxLxA)	205x65x164mm

60035

30,00€



LÂMPADA DE TRABALHO PORTÁTIL LED



REPOSIÇÕES DISPONÍVEIS

Tensão	20V
Potência	500-1000Lm
Modos de iluminação	3
LED	Si/Yes
Compatível com	60012, 60013, 60015, 60016, 60017
Peso	0,40Kg
Dimensões (CxLxA)	70x80x185mm

60065

899,00€

41.00 - 1 10



NEW

MACACO HIDRÁULICO DE CARRINHO 3T DE BAIXO PERFIL A BATERIA



VÍDEO TUTORIAL



REPOSIÇÕES DISPONÍVEIS

Capacidade	3T
Compatível com	60013, 60015, 60016, 60017
Tensão	20V
LED	No
Altura mínima	85mm
Altura máxima	508mm
Tempo de elevação (sem carga)	18-20s
Tempo de descida (sem carga)	7-10s
Tempo de elevação (com carga)	48-60s
Tempo de descida (com carga)	10-12s
Peso	41,00Kg
Dimensões (CxLxA)	770x355x1107mm



60067

515,50€

7.50 - 1 18



NEW

SANGRADOR DE FREIOS ELÉTRICO A BATERIA



REPOSIÇÕES DISPONÍVEIS

Pressão do trabalho	0,6-3,0BAR
Tensão	12-24V DC / 110-220V AC
Potência	48W
Adaptadores	17
Caudal	2,2LPM
Compatível com	60012, 60013, 60015
Peso	7,50Kg
Dimensões (CxLxA)	240x200x280mm





60040

440,00€

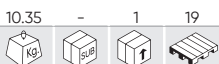

MÁQUINA DE JARDIM MULTIFUNCIONAL BATERIA (4 EM 1)



Tensão	20V
Motosserra telescópica	4500RPM
Cortador de sebes	1200RPM
Cabeça de rosca	7000RPM
Disco de corte	7000RPM
Comprimento máximo	2,25m
LED	No
Compatível com	60012, 60013, 60015, 60016, 60017
Peso	10,35Kg



REPOSIÇÕES DISPONÍVEIS

60027

99,00€

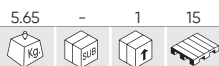

PULVERIZADOR ELÉTRICO INDUSTRIAL DE MOCHILA COM TANQUE DE 15L

Tensão	20V
Capacidade do depósito	15L
Pressão do trabalho	0,3-0,45Mpa
Distância de pulverização	1-1,2m
LED	No
Compatível com	60012, 60013, 60016, 60017
Peso	5,65Kg
Dimensões (CxLxA)	350x170x660mm



60031

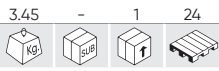

ELETROSERRA TELESCÓPICA

Tensão	20V
Potência	230W
Velocidade sem carga	1450RPM
Comprimento da serra	457mm
Capacidade de corte	18mm
LED	No
Compatível com	60012, 60013, 60015, 60016, 60017
Peso	3,45Kg
Dimensões (CxLxA)	920x215x192mm

142,00€



REPOSIÇÕES DISPONÍVEIS

60030

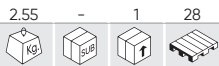

SOPRADOR DE FOLHAS



REPOSIÇÕES DISPONÍVEIS

Tensão	20V
Potência	280W
Taxa de fluxo de ar	312m ³ /h, 520m ³ /h
Potência sonora (Lw)	90dB
Velocidade sem carga	15.000RPM
LED	No
Compatível com	60012, 60013, 60015, 60016, 60017
Peso	2,55Kg
Dimensões (CxLxA)	407x205x285mm

112,00€

60029

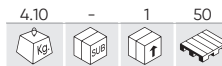

SERRA ELÉTRICA COM MOTOR BRUSHLESS



REPOSIÇÕES DISPONÍVEIS

Tensão	20V
Potência	720W
Velocidade de cadeia	7,8m/s
Comprimento da lâmina	254mm
Comprimento de corte	220mm
Passo da corrente	9,5mm (3/8")
LED	No
Compatível com	60012, 60013, 60015, 60016, 60017
Peso	4,10Kg
Dimensões (CxLxA)	600x225x245mm

240,00€

60068

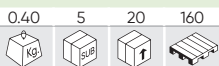

NEW

FERRO DE SOLDAR SUPER-RÁPIDO A BATERIA



Tensão	20V
Temperatura de trabalho	180-480°C
Tela	Sí/Yes
Comprimento do cabo	1m
Proteção	Apagado automático/Auto-sleep
Peso	0,40Kg
Dimensões (CxLxA)	160x110x105mm

42,00€

60039



LAVADORA DE ALTA PRESSÃO A BATERIA BRUSHLESS



VIDEO TUTORIAL



REPOSIÇÕES DISPONÍVEIS

Tensão	20V
Precisão	355PSI
Taxa de fluxo máxima	2,4L/min
Taxa de fluxo mínima	2,0L/min
LED	No
Compatível com	60012, 60013, 60015, 60016, 60017
Peso	3,30Kg
Dimensões (CxLxA)	430x75x220mm

265,00€

60063C

319,00€

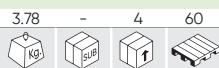

NEW

TESOURA DE PODA A BATERIA COM MALETA

Tensão	18V
Capacidade de corte	0, 15, 25, 30mm
Força	2600N
Material	SK5
LED	No
Compatível com	60012, 60015
Inclui	60013, 60016
Peso	1,50Kg
Dimensões (CxLxA)	105x77x310mm



CONTÉM

REF.	DESCRIÇÃO					€
60063	TESOURA DE PODA A BATERIA	1.10	-	10	180	169,00€
60013	4.0 AH BATERIA DE LITIO	0.75	-	5	700	80,00€
60016	CARREGADOR 20V - 4A	0.80	-	5	210	49,00€

60045

298,00€

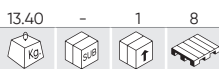

CORTA-RELVA SEM FIO

Tensão	40V
Potência	800W
Capacidade	35L
Altura de corte	25-75mm
Diâmetro de corte	370mm
LED	No
Compatível com	60013, 60016, 60017
Peso	13,40Kg
Dimensões (CxLxA)	680x450x320mm



REPOSIÇÕES DISPONÍVEIS

54252

199,00€

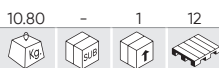

VARREDORA DE IMPULSO MANUAL

Capacidade	20L
Velocidade máxima de varredura	180m2/h
Diâmetro da escova de disco	260mm
Tamanho da escova cilíndrica	108x350mm
Peso	10,80Kg
Dimensões (CxLxA)	1200x650x980mm
Dimensões dobradas	625x548x290mm



VÍDEO TUTORIAL



REPOSIÇÕES DISPONÍVEIS

**USE-OS COM BATERIAS JBM:
UMA ÚNICA BATERIA ADEQUADA PARA TODAS AS FERRAMENTAS**

Três tipos de bateria e dois tipos de carregador. Escolha o que você preferir!



60066 28,00€

0.38 - 5 240 **NEW**

CARREGADOR 20V - 2A

Tensão	DC-20V
Entrada de carga	100-240V AC 50/60Hz
Saída de carga	2A
Tempo de carregamento	2Ah 50+/- 10min / 4Ah 90+/- 15min / 6Ah 150+/- 15min
Peso	0,38Kg

60069 59,00€

0.16 5 20 5460 **NEW**

CARREGADOR SEM FIO A BATERIA

Tensão	20V
Potência de saída	15W
Compatível com	60012, 60013, 60015
Porta de carga	Sin contacto/Wireless/USB-A/USB-C
Brilho	360Lm
Modos de iluminação	2
Peso	0,16Kg
Dimensões (CxLxA)	109x75x40mm

60012 48,00€

0.45 - 5 920

2.0 AH BATERIA DE LITIO

Tipo de pilha	LI-ION
Tensão	DC-20V
Capacidade	2.0Ah
Peso	0,45Kg
Compatível com	60016, 60017

60013 80,00€

0.75 - 5 700

4.0 AH BATERIA DE LITIO

Tipo de pilha	LI-ION
Tensão	DC-20V
Capacidade	4.0Ah
Peso	0,75Kg
Compatível com	60016, 60017

60015 138,00€

1.00 - 5 630

6.0 AH BATERIA DE LITIO

Tipo de pilha	LI-ION
Tensão	DC-20V
Capacidade	6.0Ah
Peso	1,00Kg
Compatível com	60016, 60017

60016 49,00€

0.80 - 5 210

CARREGADOR 20V - 4A

Tensão	DC-20V
Entrada de carga	100-240V AC 50/60Hz
Saída de carga	4A
Tempo de carregamento	2Ah 30+/- 10min / 4Ah 60+/- 15min / 6Ah 90+/- 15min
Peso	0,80Kg

60017 64,00€

0.80 - 5 290

CARREGADOR RÁPIDO 20V - 6A

Tensão	DC-20V
Entrada de carga	100-240V AC 50/60Hz
Saída de carga	6A
Tempo de carregamento	2Ah 30+/- 10min / 4Ah 45+/- 10min / 6Ah 60+/- 15min
Peso	0,80Kg

60059C

167,00€



BERBEQUIM DE IMPACTO SEM ESCOVAS 3/8" 250 NM COM CAIXA

Medida do quadrado	3/8"
Tensão	12V
Potência	435W
Torque de desaperto	250Nm
Velocidade nominal	1200,1800, 2700RPM
Impulsos IPM	1100, 2100, 3200
Velocidades	3
LED	Si/Yes
Inclui	60059, 60025, 60026
Compatível com	60025, 60026
Peso	3,00Kg
Dimensões (CxLxA)	126x69x184mm



REPOSIÇÕES DISPONÍVEIS

CONTÉM

REF.	DESCRIÇÃO					€
60059	BERBEQUIM DE IMPACTO SEM ESCOVAS 3/8" 250 NM	1.15	-	5	36	99,00€
60025	CARREGADOR DE 12 V - PARA REF. 60026	0.30	5	4	700	34,00€
60026	BATERIA DE ÍON DE LÍTIO 2.0 A*H	0.20	5	40	1400	40,50€

60060C

165,00€



BERBEQUIM DE IMPACTO SEM ESCOVAS 1/4" 150 NM COM CAIXA

Medida do quadrado	1/4"
Tensão	12V
Potência	396W
Torque de desaperto	150Nm
Velocidade nominal	1200, 1800, 2700RPM
Impulsos IPM	1100, 2100, 3200
Velocidades	3
LED	Si/Yes
Inclui	60060, 60025, 60026
Compatível com	60025, 60026
Peso	3,00Kg
Dimensões (CxLxA)	126x69x184mm



REPOSIÇÕES DISPONÍVEIS

CONTÉM

REF.	DESCRIÇÃO					€
60060	BERBEQUIM DE IMPACTO SEM ESCOVAS 1/4" 150 NM	0.95	-	5	36	99,00€
60025	CARREGADOR DE 12 V - PARA REF. 60026	0.30	5	4	700	34,00€
60026	BATERIA DE ÍON DE LÍTIO 2.0 A*H	0.20	5	40	1400	40,50€

60062C

216,00€

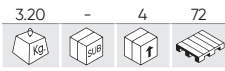

ROQUETE ELÉCTRICO DE 1/2" BRUSHLESS COM CAIXA

Medida do quadrado	1/2"
Tensão	12V
Potência	360W
Torque de aperto	80Nm
Torque de desaperto	80Nm
Velocidade nominal	175RPM
Inclui	60062, 60025, 60026
LED	Si/Yes
Compatível com	60025, 60026
Peso	3,03Kg
Dimensões (CxLxA)	400x315x91mm



REPOSIÇÕES DISPONÍVEIS

CONTÉM

REF.	DESCRIÇÃO					€
60062	ROQUETE ELÉCTRICO DE 1/2" BRUSHLESS -12V	1.90	-	5	150	169,00€
60025	CARREGADOR DE 12 V - PARA REF. 60026	0.30	5	4	700	34,00€
60026	BATERIA DE ÍON DE LÍTIO 2.0 A*H	0.20	5	40	1400	40,50€

60058C

154,00€

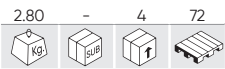

MARTELO PERFURADOR SEM ESCOVAS 12V COM CAIXA

Tensão	12V
Potência	350W
Binário máximo	45Nm
Velocidade nominal	1700RPM
Taxa de impacto	6750, 25500BPM
Ø de perfuração em concreto	8mm
Ø de perfuração em aço	10mm
Ø perfuração em madeira	25mm
Velocidades	2
amanho do mandril	Ø10mm
LED	Si/Yes
Inclui	60058, 60025, 60026
Compatível com	60025, 60026
Peso	2,80Kg
Dimensões (CxLxA)	168x185x56mm



REPOSIÇÕES DISPONÍVEIS

CONTÉM

REF.	DESCRIÇÃO					€
60058	MARTELO PERFURADOR SEM ESCOVAS 12V	1.00	-	5	70	91,00€
60025	CARREGADOR DE 12 V - PARA REF. 60026	0.30	5	4	700	34,00€
60026	BATERIA DE ÍON DE LÍTIO 2.0 A*H	0.20	5	40	1400	40,50€

60061C

149,00€



FERRAMENTA DE CORTE SEM FIOS DE 12V COM CAIXA

Tensão	12V
Potência	165W
Velocidade nominal	18500RPM
Diâmetro do disco	76mm
Diâmetro do eixo	M5
Vibrações por minuto	18.500/min
Inclui	60061, 60025, 60026
LED	No
Peso	2,46Kg
Dimensões (CxLxA)	163x113x89mm



REPOSIÇÕES DISPONÍVEIS



CONTÉM

REF.	DESCRIÇÃO					€
60061	FERRAMENTA DE CORTE SEM FIOS DE 12V	0.56	-	5	45	77,00€
60025	CARREGADOR DE 12 V - PARA REF. 60026	0.30	5	4	700	34,00€
60026	BATERIA DE ÍON DE LÍTIO 2.0 A*H	0.20	5	40	1400	40,50€

ACESSÓRIOS

REF.	DESCRIÇÃO					€
17543	A DISCO DE CORTE 76X1,2 MM REF. 60061	0.24	-	20	400	1,60€
17544	B DISCO MÚLTIPLO DE CARBONETO 76X1,0 MM REF. 60061	0.68	-	20	9999	5,00€
17545	C DISCO DE CORTE DE DIAMANTE 76X1,6 MM REF. 60061	0.79	-	20	-	3,75€

60056

142,00€



MINI SERRA DE 12V



REPOSIÇÕES DISPONÍVEIS

Tensão	12V
Potência	230W
Velocidade nominal	8m/s
Capacidade máxima de corte	100mm
Comprimento da serra	160mm
LED	No
Compatível com	60025, 60026
Peso	1,10Kg
Dimensões (CxLxA)	135x100x390mm

60055

78,00€



RÁDIO SEM FIOS A PILHAS - 12V



Tensão	12V
Potência	10W
Compatível com	60025, 60026
Conectividade Bluetooth	15m
Peso	1,01Kg
Dimensões (CxLxA)	197x138x106mm
Incluindo a bateria	No

54769 200,00€

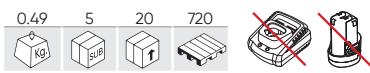

ROQUETE SEM FIOS DE 1/4" - 3,6V COM CARREGADOR



VIDEO TUTORIAL



Medida do quadrado	1/4"
Tensão	3,6V
Potência	7,2W
Binário máximo do motor	3Nm
Torque manual máximo	62,3Nm
Velocidade nominal	320RPM
LED	Si/Yes
Carregador	USB Tipo C/ USB Type C
Tipo de pilha	Lithium-ION/Litio-ION 3,6V, 2,0Ah
Dimensões (CxLxA)	35x215x35mm

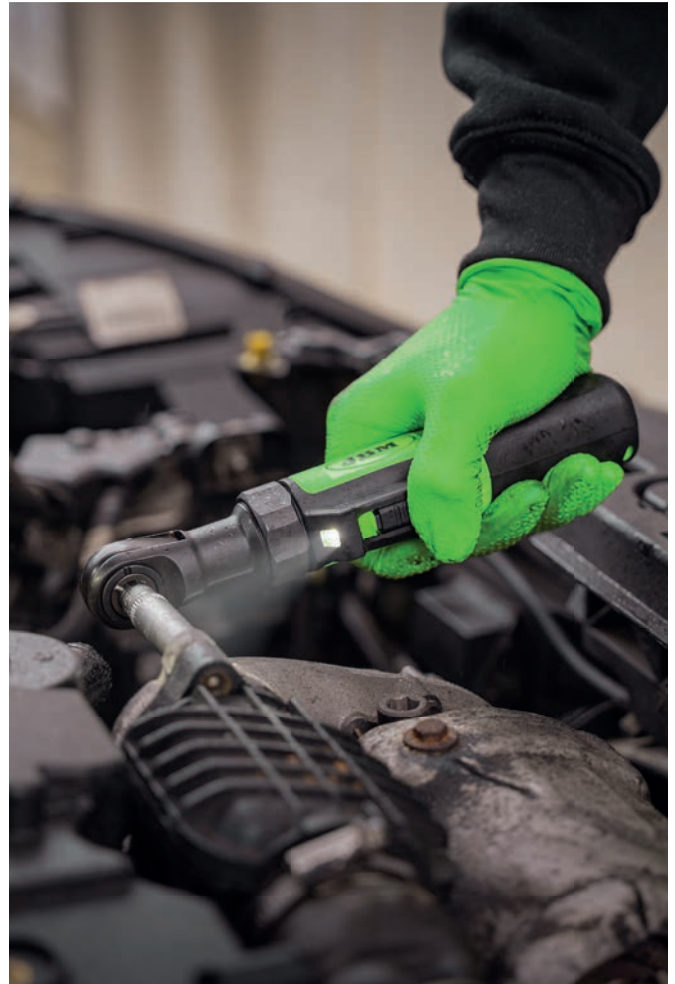

54860 54,50€



PARAFUSADEIRA A BATERIA DE 3 VELOCIDADES COM PONTAS

Tamanho do eixo	1/4"
Tensão	4V
Torque de aperto	5Nm
Velocidade nominal	300RPM
Bateria	LI-ION 1500mAh
Velocidades	3
Peso	1,40Kg
Dimensões (CxLxA)	183x35x35mm



- x4 T10, T15, T20, T25
- x5 PH0, PH1, PH2 (x2), PH3
- x4 PZ0, PZ1, PZ2, PZ3
- x4 SL3, SL4, SL5, SL6
- x4 H3, H4, H5, H6
- x4 S0, S1, S2, S3

54683 58,00€

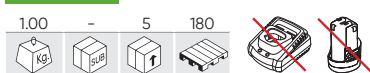

CONJUNTO DE CHAVES DE FENDAS E BROCAS SEM FIOS

Medida do quadrado	1/4"
Tensão	3,6V
Torque de aperto	6Nm
Velocidade nominal	210RPM
Bateria	LI-ION 1300mAh
LED	Si/Yes
Peso	1,00Kg
Dimensões (CxLxA)	180x45x145mm



VIDEO TUTORIAL



REPOSIÇÕES DISPONÍVEIS





60025

34,00€

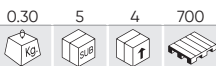

CARREGADOR DE 12 V - PARA REF. 60026



Tensão	12V
Entrada de carga	100-240V AC 50/60Hz
Saída de carga	2A
Tempo de carregamento	60 +/-10min (60026)
Peso	0,30Kg

60026

40,50€

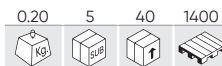

BATERIA DE ÍON DE LÍTIO 2.0 A*H



Tipo de pilha	LI-ION
Tensão	12V
Capacidade	2.0Ah
Peso	0,20Kg
Compatível com	60025

ACESSÓRIOS

REF.	DESCRIÇÃO	KG	BOX	UN	MM	€
14622	BANDEJA PARA REF. 60001, 60003, 60004, 60020, 60029, 60033, 60037, 60038	0.95	-	10	360	18,00€
14623	GANCHO PARA REF. 60043, 60042, 60046, 60051, 60052	0.10	-	10	800	8,00€
14624	BANDEJA PARA REF. 60007, 60010, 60011	0.65	-	10	300	18,00€
14625	GANCHO PARA REF. 60009, 60049, 60054	0.50	-	10	700	14,00€
14626	GANCHO PARA REF. 60023, 60032, 60044, 60047, 60050	0.10	-	10	-	7,00€
16364	CABIDE PONTA COMPRIDA 280MM	0.20	10	200	9999	3,50€



14622



14623



14624



14625



14626



16364

LUZES

- 160 LÂMPADAS DE INSPEÇÃO
- 163 LANTERNAS DE CABEÇA
- 164 GAMBIARRAS
- 165 FOCOS LED
- 166 ILUMINAÇÃO DE CAPÔ
- 168 PIRILAMPOS
- 170 LÂMPADA DE TRABALHO
- 172 SINALIZAÇÃO
- 173 ACESSÓRIOS E PEÇAS DE REPOSIÇÃO

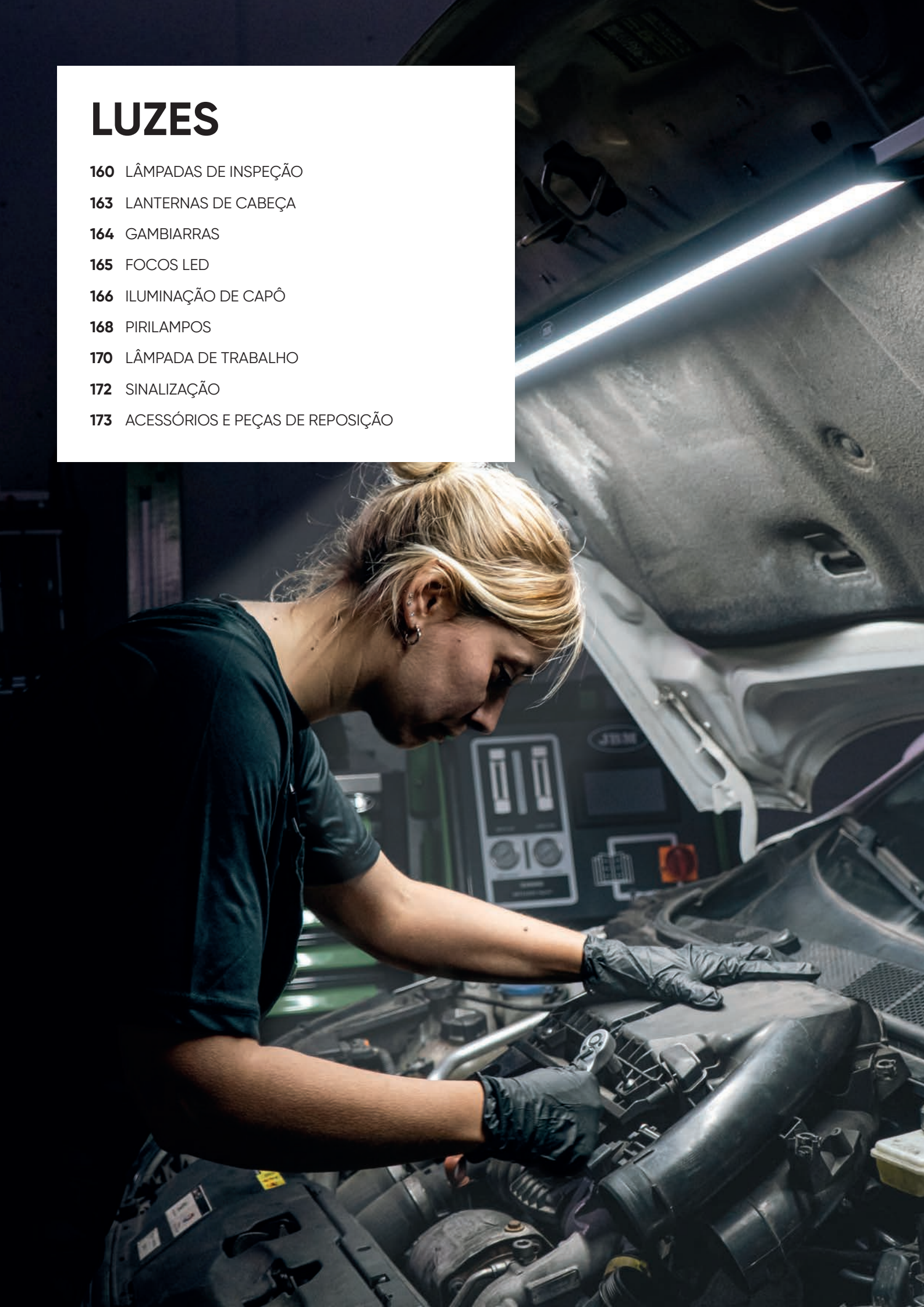

GAMBIARRA COM BASE MAGNÉTICA ARTICULADA

REF.	LM	W	V	LUZ	BATERIA	mAh	IP					€
54122	300Lm	3W	3,7V	XPE, COB	LI-ION	2000mAh	IP44	0.39	12	24	384	38,00€
54123	500Lm	3-5W	3,8V	XPE, COB	LI-ION	4000mAh	IP44	0.39	12	24	384	40,00€
54124	1000Lm	3-10W	3,7V	XPE, COB	LI-ION	4000mAh	IP44	0.39	12	24	384	47,00€



EM EXPOSITOR DE 12 UDS



53734

19,80€

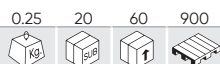

LÂMPADA LED COM BASE ARTICULADA E IMAN - 400LM



EM EXPOSITOR DE 20 UDS



Brilho	30-400Lm
Potência	9,62W
Tensão	3,7V
Tipo de LED	COB
Modos de iluminação	1
Intensidade de luz regulável	Si/Yes
Tipo de pilha	LI-ION
Capacidade da bateria	2600mAh
Tempo de trabalho	2,5h (400Lm), 10h (30Lm)
Tempo de carregamento	3-4h
Método de carregamento	USB C
Tipo	Recargable/Rechargeable
Magnetizado	Si/Yes
Proteção IP	IP44
Peso	0,25Kg
Dimensões (CxX)	380x32mm

54567

29,00€

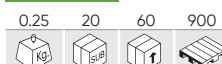

LÂMPADA LED ULTRAVIOLETA REGULÁVEL COM BASE IMANTADA ARTICULADA - 500LM



EM EXPOSITOR DE 20 UDS



Brilho	60-500Lm
Potência	5W
Tensão	3,7V
Tipo de LED	COB, SMD, UV
Modos de iluminação	4
Intensidade de luz regulável	Si/Yes
Tipo de pilha	LI-ION
Capacidade da bateria	2200mAh
Tempo de trabalho	2-2,5-6-21,5h
Tempo de carregamento	3H
Método de carregamento	USB C
Tipo	Recargable/Rechargeable
Magnetizado	Si/Yes
Peso	0,25Kg
Dimensões (CxXxA)	42x35x383mm

LÂMPADA LED

REF.	LM	W	V	LUZ	BATERIA	mAh	IP						€
54599	100-500Lm	3-10W	5V	COB, SMD	LI-ION	800mAh	IPX2	0.12	20	40	1840	28,00€	
54600	120-360Lm	3-5W	3,7V	XPE, COB	LI-ION	2000mAh	IPX2	0.16	20	40	2080	26,00€	
54601	160-400Lm	3-5W	3,7V	XPE, COB	LI-ION	2000-4000mAh	IPX2	0.21	10	20	1280	30,50€	



EM EXPOSITOR DE 20 UDS

53776 19,10€

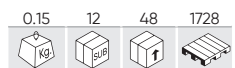

MINI LÂMPADA LED COM BASE ARTICULADA E IMAN - 300LM



EM EXPOSITOR DE 12 UDS

Brilho	90-300Lm
Potência	3-5W
Tensão	3,7V
Tipo de LED	XPE, COB
Modos de iluminação	3
Tipo de pilha	LI-ION
Capacidade da bateria	1500mAh
Tempo de trabalho	3,5-6h
Tempo de carregamento	2,5h
Método de carregamento	Micro USB
Tipo	Recargable/Rechargeable
Magnetizado	Si/Yes
Peso	0,15Kg
Dimensões (CxLxA)	140x73x23mm

52987 20,00€

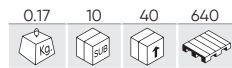

LÂMPADA LED DE BOLSO - 120LM



EM EXPOSITOR DE 10 UDS

Brilho	120Lm
Potência	4W
Tensão	3,7V
Tipo de LED	COB
Tipo de pilha	LI-ION
Capacidade da bateria	1000mAh
Tempo de trabalho	2,5h
Tempo de carregamento	1h
Método de carregamento	Micro USB
Magnetizado	Si/Yes
Peso	0,17Kg
Dimensões (CxLxA)	160x30x20mm

53216

49,00€

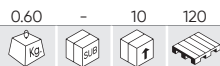

LÂMPADA LED PORTÁTIL COM BASE ARTICULADA E IMAN - 170LM



Brilho	170Lm
Potência	2W
Tensão	3,7-5V
Tipo de LED	XPE, COB
Modos de iluminação	2
Tipo de pilha	LI-ION
Capacidade da bateria	2000mAh
Tempo de trabalho	3-4h
Tempo de carregamento	4-5h
Método de carregamento	Micro USB
Magnetizado	Si/Yes
Peso	0,60Kg
Dimensões (CxX)	390x100mm

52536

57,00€

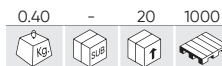

LÂMPADA LED PORTÁTIL SLIM - 200LM



Brilho	200Lm
Potência	2W
Tensão	3,7V
Tipo de LED	XPE, COB
Modos de iluminação	2
Tipo de pilha	LI-ION
Capacidade da bateria	1900mA
Tempo de trabalho	3,5-5h
Tempo de carregamento	4h
Método de carregamento	Cargador/Charger
Tipo	Recargable/Rechargeable
Magnetizado	Si/Yes
Peso	0,40Kg
Dimensões (CxX)	360x50mm

51889

49,00€

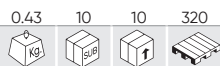

LÂMPADA LED PORTÁTIL ARTICULADA COM DUPLO ÍMAN - 60LM



Brilho	60Lm
Potência	2W
Tensão	3,6V
Tipo de LED	XPE
Modos de iluminação	2
Tipo de pilha	LI-ION
Capacidade da bateria	2200mAh
Tempo de trabalho	5h
Tempo de carregamento	3-4h
Método de carregamento	Cargador/Charger
Tipo	Recargable/Rechargeable
Magnetizado	Si/Yes
Peso	0,43Kg
Dimensões (CxX)	255x56mm

54379

28,00€

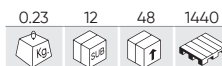

FOCO LED PORTÁTEIS COM BASE IMANTADA E CARREGAMENTO SOLAR - 800LM



EM EXPOSITOR DE 12 UDS

Brilho	80-800Lm
Potência	3-10W
Tensão	5,2V
Tipo de LED	XPE, COB
Modos de iluminação	4
Tipo de pilha	LI-ION
Capacidade da bateria	4-12h
Tempo de carregamento	3,5h
Método de carregamento	Solar, USB C
Tipo	Recargable/Rechargeable
Magnetizado	Si/Yes
Incluí	USB C
Peso	0,23Kg
Dimensões (CxLxA)	140x73x20mm

53217

47,00€



LÂMPADA LED DE ARTICULAÇÃO FLEXÍVEL COM BASE IMANTADA - 200LM

Brilho	200Lm
Tensão	5V
Tipo de LED	XPE, COB
Tipo de pilha	LI-ION
Capacidade da bateria	2200mAh
Tempo de trabalho	4h
Tempo de carregamento	4h
Método de carregamento	Micro USB
Magnetizado	Si/Yes
Peso	0,30Kg
Dimensões (CxLxA)	120x40x265mm



53780

14,50€



LÂMPADA LED - 400LM

Brilho	400Lm
Potência	6W
Tensão	220-240V
Tipo de LED	COB
Proteção IP	IP20
Peso	0,45Kg
Dimensões (CxLxA)	450x40x30mm



52384

29,00€



LÂMPADA LED EXTRA PLANA - 200LM

Brilho	200Lm
Potência	3W
Tensão	12-24V
Tipo de LED	COB
Peso	0,33Kg
Dimensões (CxLxA)	325x90mm



54004

16,00€

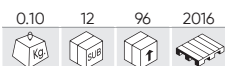

LANTERNA FRONTAL LED AJUSTÁVEL - 350LM

Brilho	150-350Lm
Potência	3-5W
Tensão	2,5-4,17V
Tipo de LED	XPE, COB
Modos de iluminação	3
Tipo de pilha	LI-ION
Capacidade da bateria	1.200mAh
Tempo de trabalho	2,5-4h
Tempo de carregamento	2,5h
Inclui	USB C
Peso	0,10Kg
Dimensões (CxLxA)	300x32x20mm



EM EXPOSITOR DE 12 UDS



54267

9,50€

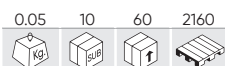

LUVA COM LANTERNA LED - 70LM

Brilho	70Lm
Potência	120mAh
Tensão	3V
Tipo de LED	XPE
Número de LEDs	6
Peso	0,05Kg
Dimensões (CxLxA)	160x32mm



MÃO DIREITA



54344

10,50€

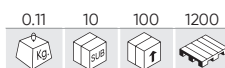

GORRO COM LANTERNA LED - 120LM



Brilho	25-60-120Lm
Potência	1W
Tensão	3,7V
Modos de iluminação	3
Tipo de pilha	LI-ION
Capacidade da bateria	250mAh
Tempo de trabalho	40min, 6-8h, 8-10h
Tempo de carregamento	2h
Método de carregamento	USB A
Magnetizado	No
Proteção IP	IP3X
Peso	0,11Kg
Dimensões (CxLxA)	210x220x20mm

54544

50,50€

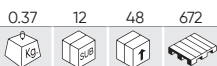

LANTERNA LED MULTIFUNCIONAL DE 800LM

Brilho	800Lm
Potência	10W
Tensão	3,7V
Tipo de LED	LEP
Capacidade da bateria	13
Número de LEDs	2800mAh
Método de carregamento	USB C
Magnetizado	No
Peso	0,36Kg
Dimensões (CxLxA)	185x53x37mm



EM EXPOSITOR DE 12 UDS



VÍDEO TUTORIAL

51573

2,50€

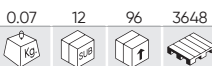

LANTERNÁ LED COM DÍNAMO - 6LM



Brilho	6Lm
Tensão	4,5V
Tipo de LED	XPE
Número de LEDs	2
Método de carregamento	Dinamo/Dynamo
Magnetizado	No
Peso	0,07Kg
Dimensões (CxLxA)	105x58mm

51326

5,80€

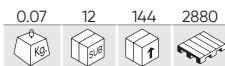

MINI LANTERNA LED - 63LM



EM EXPOSITOR DE 12 UDS

Brilho	63Lm
Tensão	9V
Tipo de LED	XPE
Número de LEDs	21
Método de carregamento	x3 Pila/Battery AAA
Magnetizado	No
Peso	0,07Kg
Dimensões (CxLxA)	95x35mm

54039

154,00€

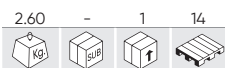

LÂMPADA LED INDUSTRIAL - 20000LM



Peças	1
Brilho	20000Lm
Potência	200W
Tensão	220V
Tipo de LED	MTC
Número de LEDs	288
Comprimento do cabo	300mm
Proteção IP	IP20
Peso	2,60Kg
Dimensões (CxX)	500x380mm

54133

547,00€



CONJUNTO DE 6 LÂMPADAS LED INDUSTRIAIS - 20000LM (REF. 54039)



Peças	6
Brilho	20000Lm
Potência	200W
Tensão	220V
Tipo de LED	MTC
Número de LEDs	288
Comprimento do cabo	300mm
Proteção IP	IP20
Peso	12,10Kg
Dimensões (CxX)	500x380mm

54088

132,00€

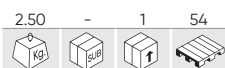

LÂMPADA LED INDUSTRIAL - 18000LM

Brilho	18000Lm
Potência	250W
Tensão	200-240V
Tipo de LED	SMD2835
Número de LEDs	240
Comprimento do cabo	400mm
Proteção IP	IP65
Peso	2,50Kg
Dimensões (CxLxA)	300x150mm



53505

77,00€



FOCO LED - 3500LM

Brilho	3500Lm
Potência	50W
Tensão	230V
Número de LEDs	60
Tempo de trabalho	+25000h
Comprimento do cabo	2m
Proteção IP	IP65
Peso	2,50Kg
Dimensões (CxLxA)	328x235x41mm



REF. DESCRIÇÃO

53506 TRIPÉ PARA FOCO LED (REF.53505)

2.40 - 8 112 36,00€



54967 **47,00€**

0.51 5 10 360 **NEW**

HOLOFOTE LED 10W COM SENSOR DE MOVIMENTO INFRAVERMELHO

Brilho	1000Lm
Potência	10W
Tensão	3,7V
Tipo de LED	COB
Tipo de pilha	LI-ION
Modos de iluminação	3 (250Lm, 500Lm, 1000Lm)
Capacidade da bateria	4400mAh
Tempo de carregamento	2,5-3H
Tempo de trabalho	3,5-10H
Magnetizado	Si/Yes
Peso	0,51Kg
Dimensões (CxLxA)	135x55x175mm

54968 **89,50€**

1.38 5 10 80 **NEW**

HOLOFOTE LED 30W COM SENSOR DE MOVIMENTO INFRAVERMELHO

Brilho	3000Lm
Potência	30W
Tensão	3,7V
Tipo de LED	COB
Tipo de pilha	LI-ION
Modos de iluminação	3 (1300Lm, 2100Lm, 3000Lm)
Capacidade da bateria	8000mAh
Tempo de carregamento	4-5H
Tempo de trabalho	2-8H
Magnetizado	Si/Yes
Peso	1,38Kg
Dimensões (CxLxA)	195x80x245mm

54271 **54,00€**

0.40 10 20 400

BARRA LED IMANTADA FLEXÍVEL COM CINTA - 1000LM

Brilho	1000Lm
Potência	10W
Tensão	3,7V
Tipo de LED	COB
Modos de iluminação	2
Tipo de pilha	LI-ION
Capacidade da bateria	1200mAh
Tempo de trabalho	2-5h
Tempo de carregamento	3-4h
Método de carregamento	USB C
Magnetizado	Si/Yes
Abertura	1200-1800mm
Peso	0,40Kg
Dimensões (CxLxA)	1800x37x22mm

54270 **42,00€**

0.20 10 20 640

BARRA LED IMANTADA FLEXÍVEL - 1000LM

Brilho	1000Lm
Potência	10W
Tensão	3,7V
Tipo de LED	COB
Modos de iluminação	2
Tipo de pilha	LI-ION
Capacidade da bateria	1200mAh
Tempo de trabalho	2-5h
Tempo de carregamento	3-4h
Método de carregamento	USB C
Magnetizado	Si/Yes
Peso	0,20Kg
Dimensões (CxLxA)	580x37x22mm

54805

478,00€



NEW

CONJUNTO DE CANDEIROS DE TECTO HEXAGONAIS

Brilho	83640Lm
Potência	615W
Eficiência	110-120Lm/W
Tensão	185-240V
Tipo de LED	2835
Número de LEDs	12
Temperatura de cor do LED	6500k
Material	Al + PC
Comprimento do cabo	1,5m Enchufe europeo/ EU Plug
Proteção IP	IP45
Peso	8,00Kg
Dimensões (CxLxA)	2435x42x4845mm

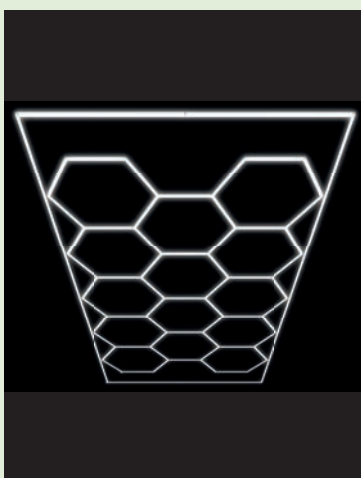
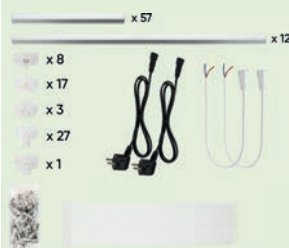

REPOSIÇÕES DISPONÍVEIS



54500

159,00€

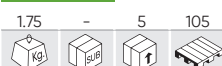

BARRA LED AJUSTÁVEL PARA CAPÔ - 5000LM



VIDEO TUTORIAL

Brilho	5000Lm
Potência	33W
Tensão	7,2V
Tipo de LED	XPE, SMD
Modos de iluminação	3
Capacidade da bateria	5000mAh
Tempo de trabalho	3-15h
Método de carregamento	USB C
Abertura	1180-1720mm
Peso	1,75Kg
Dimensões (CxLxA)	1172x50x20mm

53570

154,00€



LÂMPADA LED PARA CAPÔ - 1200LM



Brilho	1200Lm
Potência	10,92W
Tensão	3,7V
Tipo de LED	COB
Modos de iluminação	3
Tipo de pilha	LI-ION
Capacidade da bateria	2600mAh
Tempo de trabalho	3-7h
Tempo de carregamento	7-8h
Método de carregamento	Micro USB
Magnetizado	No
Peso	2,70Kg
Dimensões (CxLxA)	1180x110x120mm

LUZ DE EMERGÊNCIA TIPO FLASH DE LEDS

54172

81,00€

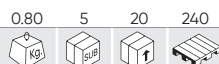

Brilho	447,07Lm
Potência	13W
Tensão	5V
Tipo de LED	SMD2835
Modos de iluminação	3
Tipo de pilha	LI-ION Recargable/Rechargeable
Capacidade da bateria	2200mAh
Tempo de trabalho	3-4h
Tempo de carregamento	2-3h
Método de carregamento	USB
Magnetizado	No
Material	PC, ABS
Temperatura de trabalho	-30~50°C
Peso	0,80Kg
Dimensões (CxLxA)	128x128x210mm



54173

87,00€

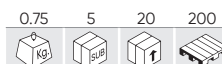

Brilho	473,62Lm
Potência	13W
Tensão	5V
Tipo de LED	SMD2835
Modos de iluminação	3
Tipo de pilha	LI-ION Recargable/Rechargeable
Capacidade da bateria	7,4V - 2200mAh
Tempo de trabalho	3-4h
Tempo de carregamento	2-3h
Método de carregamento	USB
Magnetizado	Si/Yes
Material	PC, ABS
Temperatura de trabalho	-30~50°C
Peso	0,75Kg
Dimensões (CxLxA)	128x128x140mm



53691

36,00€

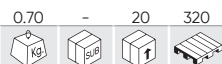

Brilho	836,68Lm
Potência	18W
Tensão	12-24V
Tipo de LED	3030SMD
Magnetizado	Si/Yes
Material	PC, PPB
Temperatura de trabalho	-30~50°C
Peso	0,70Kg
Dimensões (CxLxA)	125x112mm



53690

34,00€



Brilho	836,68Lm
Potência	18W
Tensão	12-24V
Tipo de LED	3030SMD
Material	PC, PPB, TPR
Temperatura de trabalho	-30~50°C
Peso	0,55Kg
Dimensões (CxLxA)	125x182mm



52375

38,00€

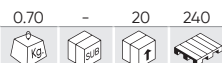

Brilho	230,64Lm
Potência	21,3W
Tensão	12-24V
Tipo de LED	SMD5730
Modos de iluminação	3
Comprimento do cabo	2,5m
Magnetizado	Si/Yes
Material	PC, ABS
Temperatura de trabalho	-30~50°C
Peso	0,70Kg
Dimensões (CxLxA)	140x140x170mm



52456

36,00€



Brilho	227,04Lm
Potência	21W
Tensão	12-24V
Tipo de LED	SMD5730
Modos de iluminação	6
Magnetizado	No
Material	PC, ABS
Temperatura de trabalho	-30~50°C
Peso	0,60Kg
Dimensões (CxLxA)	128x128x240mm



51964

28,00€

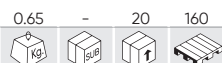

Brilho	300,93Lm
Potência	43,5W
Tensão	12V
Bolbo	H1
Magnetizado	No
Material	PC, ABS
Temperatura de trabalho	-30~50°C
Peso	0,65Kg
Dimensões (CxLxA)	128x128x240mm



51965

34,00€



Brilho	293,43Lm
Potência	41,74W
Tensão	24V
Bolbo	H1
Magnetizado	No
Material	PC, ABS
Temperatura de trabalho	-30~50°C
Peso	0,68Kg
Dimensões (CxLxA)	128x128x240mm



LUZ DE EMERGÊNCIA TIPO FLASH DE LEDS

51960 34,00€

0.75 - 20 240



Brilho	299Lm
Potência	43,84W
Tensão	12V
Bolbo	H1
Comprimento do cabo	4m
Magnetizado	Si/Yes
Material	PC, ABS
Temperatura de trabalho	-30~50°C
Peso	0,75Kg
Dimensões (CxX)	140x140x170mm



51961 39,00€

0.78 - 20 240



Brilho	335,13Lm
Potência	33,55W
Tensão	24V
Bolbo	H1
Comprimento do cabo	4m
Magnetizado	Si/Yes
Material	PC, ABS
Temperatura de trabalho	-30~50°C
Peso	0,78Kg
Dimensões (CxX)	140x140x170mm



51962 25,00€

0.57 - 20 240

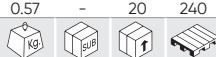

Brilho	269,20Lm
Potência	33,8W
Tensão	12V
Bolbo	H1
Magnetizado	No
Material	PC, ABS
Temperatura de trabalho	-30~50°C
Peso	0,57Kg
Dimensões (CxLxA)	140x140x155mm



51963 29,50€

0.55 - 20 240



Brilho	324,46Lm
Potência	33,62W
Tensão	24V
Bolbo	H1
Magnetizado	No
Material	PC, ABS
Temperatura de trabalho	-30~50°C
Peso	0,55Kg
Dimensões (CxX)	140x140x155mm



51966 18,00€

0.31 - 50 800



Brilho	57,75Lm
Potência	9,12W
Tensão	12-110V
Bolbo	Xenon
Magnetizado	No
Material	PC, ABS
Temperatura de trabalho	-30~50°C
Peso	0,31Kg
Dimensões (CxLxA)	161x161x131mm



LUZ DE EMERGÊNCIA TIPO FLASH DE LEDS

REF.	DESCRIÇÃO					€
52827	LUZ DE EMERGÊNCIA TIPO FLASH DE LEDS - AMBAR	0.50	-	20	400	46,00€
52828	LUZ DE EMERGÊNCIA PERFIL BAIXO TIPO FLASH ROTATIVO	0.50	-	20	320	46,00€
52910	LUZ DE EMERGÊNCIA TIPO FLASH DE LEDS	0.50	-	20	320	46,00€



FOCO AUXILIAR LED LUZ CONCENTRADA

52568

28,00€

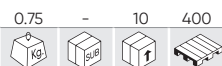

Brilho	1450Lm
Potência	27W
Tensão	10-40V
Tipo de LED	3W
Número de LEDs	9
Feixe de luz	Concentrada/Concentrated
Tempo de trabalho	20000h
Magnetizado	Si/Yes
Material	Aluminio/Aluminium
Proteção IP	IP68
Peso	0,75Kg
Dimensões (CxLxA)	107x127x50mm



52569

28,00€



Brilho	1450Lm
Potência	27W
Tensão	10-40V
Tipo de LED	3W
Número de LEDs	9
Feixe de luz	Concentrada/Concentrated
Tempo de trabalho	20000h
Magnetizado	Si/Yes
Material	Aluminio/Aluminium
Proteção IP	IP68
Peso	0,70Kg
Dimensões (CxLxA)	125x50x137mm



53048

89,00€

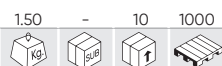

Brilho	3600Lm
Potência	40W
Tensão	9-36V
Tipo de LED	10W
Número de LEDs	4
Feixe de luz	Concentrada/Concentrated
Tempo de trabalho	50000h
Magnetizado	No
Material	Aluminio/Aluminium
Proteção IP	IP68
Peso	1,50Kg
Dimensões (CxLxA)	123x87x118mm



53051

158,00€

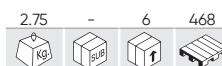

Brilho	7200Lm
Potência	80W
Tensão	9-36V
Tipo de LED	10W
Número de LEDs	8
Feixe de luz	Concentrada/Concentrated
Tempo de trabalho	50000h
Magnetizado	No
Material	Aluminio/Aluminium
Proteção IP	IP68
Peso	2,75Kg
Dimensões (CxLxA)	165x95x191,5mm



52415

19,00€

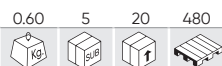

Brilho	1450Lm
Potência	27W
Tensão	10-40V
Tipo de LED	3W
Número de LEDs	9
Feixe de luz	Concentrada/Concentrated
Tempo de trabalho	20000h
Magnetizado	No
Material	Aluminio/Aluminium
Proteção IP	IP68
Peso	0,60Kg
Dimensões (CxLxA)	110x50x128mm



52414

19,00€

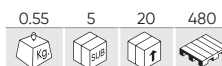

Brilho	1450Lm
Potência	27W
Tensão	10-40V
Tipo de LED	3W
Número de LEDs	9
Feixe de luz	Concentrada/Concentrated
Tempo de trabalho	20000h
Magnetizado	No
Material	Aluminio/Aluminium
Proteção IP	IP68
Peso	0,55Kg
Dimensões (CxLxA)	118x128x50mm



53047

330,00€

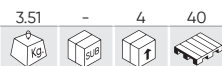

Brilho	3200Lm
Potência	80W
Tensão	12-24V
Tipo de LED	5W
Número de LEDs	10
Feixe de luz	Concentrada/Concentrated
Tempo de trabalho	50000h
Magnetizado	Si/Yes
Material	Aluminio/Aluminium
Proteção IP	IP67
Peso	3,51Kg
Dimensões (CxLxA)	185x150x230mm



55090

47,50€



Brilho	2880Lm
Potência	48W
Tensão	9-36V
Tipo de LED	3W
Número de LEDs	16
Feixe de luz	Dispersa/Scattered
Tempo de trabalho	50000h
Magnetizado	No
Material	Aluminio/Aluminium
Proteção IP	IP68
Peso	0,87Kg
Dimensões (CxLxA)	127x55x155mm



FOCO AUXILIAR LED LUZ DISPERSA

53428

18,00€

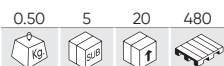

Brilho	1800Lm
Potência	27W
Tensão	10-30V
Tipo de LED	SMD
Número de LEDs	9
Feixe de luz	Dispersa/Scattered
Tempo de trabalho	30000h
Magnetizado	No
Material	Aluminio/Aluminium
Proteção IP	IP67
Peso	0,50Kg
Dimensões (CxLxA)	126x48x108mm



53429

18,00€

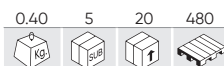

Brilho	1800Lm
Potência	27W
Tensão	10-20V
Tipo de LED	SMD
Número de LEDs	9
Feixe de luz	Dispersa/Scattered
Tempo de trabalho	30000h
Magnetizado	No
Material	Aluminio/Aluminium
Proteção IP	IP68
Peso	0,40Kg
Dimensões (CxLxA)	115x48x128mm



52566

28,00€

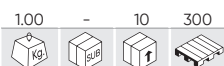

Brilho	1450Lm
Potência	27W
Tensão	10-40V
Tipo de LED	3W LED
Número de LEDs	9
Feixe de luz	Dispersa/Scattered
Tempo de trabalho	20000h
Magnetizado	Si/Yes
Material	Aluminio/Aluminium
Proteção IP	IP68
Peso	1,00Kg
Dimensões (CxLxA)	117x55x160mm



52567

29,00€

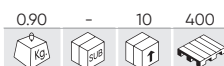

Brilho	1450Lm
Potência	27W
Tensão	10-40V
Tipo de LED	3W LED
Número de LEDs	9
Feixe de luz	Dispersa/Scattered
Tempo de trabalho	20000h
Magnetizado	Si/Yes
Material	Aluminio/Aluminium
Proteção IP	IP68
Peso	0,90Kg
Dimensões (CxLxA)	127x45x170mm



52302

25,40€

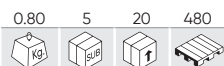

Brilho	1450Lm
Potência	27W
Tensão	10-40V
Tipo de LED	3W
Número de LEDs	9
Feixe de luz	Dispersa/Scattered
Tempo de trabalho	20000h
Magnetizado	No
Material	Aluminio/Aluminium
Proteção IP	IP68
Peso	0,80Kg
Dimensões (CxLxA)	117x47x135mm



52303

28,50€

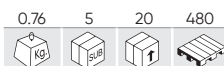

Brilho	1450Lm
Potência	27W
Tensão	10-40V
Tipo de LED	3W
Número de LEDs	9
Feixe de luz	Dispersa/Scattered
Tempo de trabalho	20000h
Magnetizado	No
Material	Aluminio/Aluminium
Proteção IP	IP68
Peso	0,76Kg
Dimensões (CxLxA)	125x50x137mm



53049

89,00€

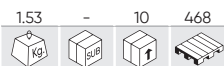

Brilho	3600Lm
Potência	40W
Tensão	9-36V
Tipo de LED	10W
Número de LEDs	4
Feixe de luz	Dispersa/Scattered
Tempo de trabalho	50000h
Magnetizado	No
Material	Aluminio/Aluminium
Proteção IP	IP68
Peso	1,53Kg
Dimensões (CxLxA)	123x87x117mm



53052

158,00€



Brilho	7200Lm
Potência	80W
Tensão	9-36V
Tipo de LED	5W
Número de LEDs	8
Feixe de luz	Dispersa/Scattered
Tempo de trabalho	50000h
Magnetizado	No
Material	Aluminio/Aluminium
Proteção IP	IP68
Peso	2,65Kg
Dimensões (CxLxA)	165x98x191,5mm



LUZES

53045

35,00€

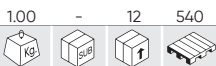

Brilho	2800Lm
Potência	48W
Tensão	10-40V
Tipo de LED	3W
Número de LEDs	16
Feixe de luz	Dispersa/Scattered
Tempo de trabalho	20000h
Magnetizado	No
Material	Aluminio/Aluminium
Proteção IP	IP67
Peso	1,00Kg
Dimensões (CxLxA)	130x55x150mm



53046

39,00€

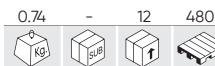

Brilho	2272Lm
Potência	24W
Tensão	9-36V
Tipo de LED	1,5W
Número de LEDs	16
Feixe de luz	Dispersa/Scattered
Tempo de trabalho	20000h
Magnetizado	No
Material	Aluminio/Aluminium
Proteção IP	IP68
Peso	0,74Kg
Dimensões (CxLxA)	129x131,5x45mm



BARRA DE SINALIZAÇÃO PARA REBOQUE

54161

99,00€



Tensão	12-24V
Modos de iluminação	4
Comprimento do cabo	7,5m
Número PIN	7
Peso	2,75Kg
Extensível	1400-2100mm
Dimensões (CxX)	1400x140mm

Homologação:

E9*3R02/17*23444*00
E9*4R00/19*23444*00
E9*6R01/29*23444*00
E9*7R02/27*23444*00
E9*10R06/00*22232*02



54163

80,00€



Tensão	12-24V
Modos de iluminação	4
Comprimento do cabo	5m
Número PIN	7
Peso	1,85Kg
Dimensões (CxLxA)	1100x140mm

Homologação:

E9*3R02/17*23444*00
E9*4R00/19*23444*00
E9*6R01/29*23444*00
E9*7R02/27*23444*00
E9*10R06/00*22232*02



50910

45,00€



Potência	4,96W
Tensão	12V
Modos de iluminação	4
Comprimento do cabo	5m
Magnetizado	No
Temperatura de trabalho	-30~50°C
Número PIN	7
Peso	1,90Kg
Dimensões (CxX)	1100x140mm

Homologação:

E4*4R-0024080
E4*6R-0124080
E4*7R-0224080
E9*10R06/02*23498*00



52838

56,00€

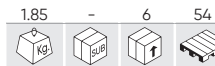

Potência	1,05W
Tensão	12V
Modos de iluminação	4
Comprimento do cabo	5m
Magnetizado	No
Temperatura de trabalho	-30~50°C
Número PIN	7
Peso	1,85Kg
Dimensões (CxX)	1100x140mm

Homologação:

E4*7R-0218756



SINALIZADOR LED PARA BARRA DE REBOQUE

REF.					€
54160L	0.20	5	20	720	19,00€
54160R	0.20	5	20	720	19,00€

Homologação:

E9*7R02/27*23444*00	E9*10R06/01*23199*00
---------------------	----------------------



54044

99,00€

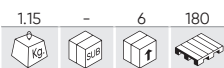

CONJUNTO DE DUAS LUZES TRASEIRAS MAGNÉTICAS SEM FIO



Tensão	12-24V
Tempo de carregamento	2-3h
Magnetizado	Si/Yes
Sem fios	20m
Número PIN	7
Peso	1,15Kg
Dimensões (CxLxA)	98x30x108mm

Homologação:

E9*10R05/01*16210*02

53151

14,00€

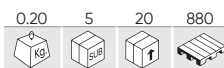

SINALIZADOR LED PARA BARRA DE REBOQUE



Potência	1,05W
Tensão	12V
Modos de iluminação	4
Magnetizado	No
Temperatura de trabalho	-30~50°C
Peso	0,20Kg
Dimensões (CxX)	106x98mm

KIT MAGNÉTICO COM 2 SINALIZADORES LED E 2 TRIÂNGULOS REFLECTORES

54162

81,00€



Tensão	12-24V
Modos de iluminação	4
Magnetizado	Si/Yes
Temperatura de trabalho	-30~50°C
Número PIN	7
Peso	1,50Kg
Dimensões (CxLxA)	118x58x93mm

Homologação:

E9*7R02/27*23444*00

51886

44,00€



Potência	4,96W
Tensão	12V
Magnetizado	Si/Yes
Temperatura de trabalho	-30~50°C
Número PIN	7
Peso	1,50Kg
Dimensões (CxX)	104x97mm

Homologação:

E4*3R-023749 E4*7R-0224080
E4*4R-0024080 E9*10R06/02*23498*00
E4*6R-0124080

52839

64,00€



Potência	1,05W
Tensão	12V
Magnetizado	Si/Yes
Temperatura de trabalho	-30~50°C
Número PIN	7
Peso	1,46Kg
Dimensões (CxX)	106x98mm

Homologação:

E4*3R-0218756 E4*7R-0218756
E4*4R-0018756 E9*10R06/02*23199*01
E4*6R-0118756

53536

34,00€



COMPROVADOR DE LUZES DE REBOQUE 7/13 PINOS

Tensão	9V
Contém	7-13Pins
Peso	0,40Kg
Dimensões (CxLxA)	270x65x56mm



54078

68,00€



LUZ DE SEGURANÇA PARA EMPILHADEIRA



Potência	15W
Tensão	10-60V
Feixe de luz	Concentrada/Concentrated
Peso	0,66Kg
Dimensões (CxLxA)	150x95x115mm

51967

16,00€

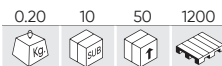

SIRENE REDONDA 12V-80V



Tensão	12-80V
Temperatura de trabalho	-30-70°C
Intensidade do som	97dB
Peso	0,20Kg
Dimensões (CxLxA)	113x50x80mm

51968

16,00€

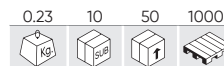

SIRENE QUADRADA 12V-80V



Tensão	12-80V
Temperatura de trabalho	-30-70°C
Intensidade do som	107dB
Peso	0,23Kg
Dimensões (CxLxA)	113x50x80mm

PILHAS DE RECAMBIO

REF.	DESCRIÇÃO				€	
51258	R03 1,5V	0.01	60	2400	134400	0,16€
10923	6F22 9V	0.05	10	500	-	1,10€
10771	R6P 1,5V	0.03	60	1200	-	0,20€
51331	R14P 1,5V	0.09	-	240	18720	0,40€
15052	ICR18650 3,7V	0.05	5	10	-	3,00€
10000	CR123A 3V	2.10	-	10	-	7,00€



51258



10923



10771



51331



15052



10000

CARREGADOR DE ISQUEIRO E TOMADA CORRENTE

REF.				€	
11107	0.06	-	250	4,90€	
13839	0.04	-	200	10,90€	
14031	0.10	10	100	1152	10,30€
14032	0.10	10	100	1200	13,50€
14033	0.10	10	100	500	4,50€
16052	0.05	10	100	-	3,40€
16053	0.05	10	100	-	4,50€
54901	0.05	20	100	2800	7,00€
54902	0.05	20	100	2000	5,50€



11107



13839



14031



14032



14033



16052 - 16053



54901



54902

ACESSÓRIOS

REF.				€	
10750	0.25	-	50	1200	17,90€
10751	0.30	-	50	-	18,40€
52843	0.90	-	20	1500	33,50€
51969	0.12	-	50	1000	14,00€
11324	0.13	-	100	-	17,50€
11325	0.12	-	50	451	17,50€



10750



10751



52843



51969



11324



11325

FERRAMENTAS PNEUMÁTICAS

- 176 APARAFUSAR
- 182 PERFURAR
- 183 CORTAR / SERRAR
- 184 LIXAR/POLIR
- 186 PISTOLAS DE AR
- 188 MANUTENÇÃO DE PNEUS
- 189 OUTROS
- 194 ENROLADORES DE MANGUEIRAS DE AR
- 196 MANGUEIRAS CONECTORES
- 197 ACESSÓRIOS E CONSUMÍVEIS
- 198 MÁQUINA DE JACTO DE AREIA



54547

298,00€

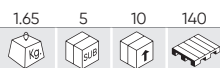

CHAVE DE IMPACTO MINI 1/2" 2247 NM



REPOSIÇÕES DISPONÍVEIS

Medida do quadrado	1/2"
Entrada de ar	1/4"
Torque de aperto	1687Nm
Torque de desaperto	2247Nm
Velocidade nominal	8500RPM
Consumo real de ar	5,5CFM (158L/min)
Pressão do trabalho	6,2BAR
Intensidade do som	91,5dB
Sistema de martelo	Doble/Twin
Velocidades	4
Golpes por minuto	1650
Peso	1,65Kg
Dimensões (CxLxA)	180x190x70mm

53689

238,00€



CHAVE DE IMPACTO 1/2" 1950NM



REPOSIÇÕES DISPONÍVEIS

Medida do quadrado	1/2"
Entrada de ar	1/4"
Torque de aperto	1329Nm
Torque de desaperto	1950Nm
Velocidade nominal	8600RPM
Consumo real de ar	4CFM (113L/min)
Pressão do trabalho	6,3BAR
Intensidade do som	105dB
Sistema de martelo	Doble/Twin
Velocidades	5
Golpes por minuto	1400
Peso	1,88Kg
Dimensões (CxLxA)	187x206x70mm

54521

129,00€

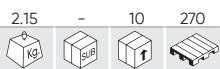

CHAVE DE IMPACTO 1/2" 1750 NM



REPOSIÇÕES DISPONÍVEIS

Medida do quadrado	1/2"
Entrada de ar	1/4"
Torque de aperto	1560Nm
Torque de desaperto	1750Nm
Velocidade nominal	7000RPM
Consumo real de ar	6,71CFM (190L/min)
Pressão do trabalho	6,2BAR
Intensidade do som	107dB
Sistema de martelo	Doble/Twin
Velocidades	4
Golpes por minuto	1100
Peso	2,15Kg
Dimensões (CxLxA)	188x61x186mm

53726

128,00€

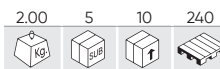

CHAVE DE IMPACTO 1/2" 1650NM



REPOSIÇÕES DISPONÍVEIS

Medida do quadrado	1/2"
Entrada de ar	1/4"
Torque de aperto	1350Nm
Torque de desaperto	1650Nm
Velocidade nominal	7000RPM
Consumo real de ar	7CFM (198L/min)
Pressão do trabalho	6,2BAR
Intensidade do som	107dB
Sistema de martelo	Doble/Twin
Velocidades	3
Golpes por minuto	950
Peso	2,00Kg
Dimensões (CxLxA)	180x710x1840mm

54770 95,00€

1.45 5 10 300 **NEW**

CHAVE DE IMPACTO MINI 1/2" 1200 NM



53608 98,00€

2.35 5 10 240

CHAVE DE IMPACTO 1/2" 1200NM



REPOSIÇÕES DISPONÍVEIS

Medida do quadrado	1/2"
Entrada de ar	1/4"
Torque de aperto	610Nm
Torque de desaperto	1200Nm
Velocidade nominal	8500RPM
Consumo real de ar	5CFM
Pressão do trabalho	6,3BAR
Intensidade do som	93,14dB
Sistema de martelo	Jumbo
Velocidades	4
Golpes por minuto	1200
Peso	1,45Kg
Dimensões (CxLxA)	135x64x179mm

Medida do quadrado	1/2"
Entrada de ar	1/2"
Torque de aperto	880Nm
Torque de desaperto	1200Nm
Velocidade nominal	7500RPM
Consumo real de ar	6,5CFM (183,5L/min)
Pressão do trabalho	6,2BAR
Intensidade do som	107dB
Sistema de martelo	Doble/Twin
Velocidades	4
Golpes por minuto	950
Peso	2,35Kg
Dimensões (CxLxA)	187x71x184mm

53588 178,00€

1.44 - 5 300

CHAVE DE IMPACTO MINI 1/2" 1302NM



REPOSIÇÕES DISPONÍVEIS

54340 296,00€

1.40 - 5 600

CHAVE DE IMPACTO ARTICULADA NANO 1/2" 813 NM



REPOSIÇÕES DISPONÍVEIS

Medida do quadrado	1/2"
Entrada de ar	1/4"
Torque de aperto	678Nm
Torque de desaperto	1302Nm
Velocidade nominal	10000RPM
Consumo real de ar	4CFM (113L/min)
Pressão do trabalho	6,2BAR
Intensidade do som	87,9dB
Sistema de martelo	Jumbo
Velocidades	6
Golpes por minuto	1600
Peso	1,44Kg
Dimensões (CxLxA)	173x109x60mm

Medida do quadrado	1/2"
Entrada de ar	1/4"
Torque de aperto	610Nm
Torque de desaperto	813Nm
Velocidade nominal	8000RPM
Consumo real de ar	8CFM (226L/min)
Pressão do trabalho	6,2BAR
Intensidade do som	92dB
Sistema de martelo	Doble/Twin
Velocidades	3
Golpes por minuto	2000
Peso	1,40Kg
Dimensões (CxLxA)	88x60x311mm



54397

249,00€

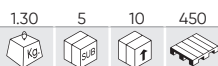

CHAVE DE IMPACTO NANO-COMPACTA DE 1/2" 1004NM



REPOSIÇÕES DISPONÍVEIS

Medida do quadrado	1/2"
Entrada de ar	1/4"
Torque de aperto	500Nm
Torque de desaperto	1004Nm
Velocidade nominal	7500RPM
Consumo real de ar	3,4CFM (96L/min)
Pressão do trabalho	6,2BAR
Intensidade do som	92dB
Sistema de martelo	Doble/Twin
Velocidades	2
Golpes por minuto	1300
Peso	1,30Kg
Dimensões (CxLxA)	85x64x141mm

51222

128,00€



CHAVE DE IMPACTO DOBLE BLISTER 1/2" 101NM



REPOSIÇÕES DISPONÍVEIS

Medida do quadrado	1/2"
Entrada de ar	1/4"
Torque de aperto	101Nm
Torque de desaperto	101Nm
Velocidade nominal	10000RPM
Consumo real de ar	3CFM (85L/min)
Pressão do trabalho	6,3BAR
Sistema de martelo	Único/Single
Velocidades	16
Golpes por minuto	1000
Peso	0,90Kg
Dimensões (CxLxA)	160x48x87mm

53733

238,00€



CHAVE DE IMPACTO NANO 1/2" 350NM



REPOSIÇÕES DISPONÍVEIS

Medida do quadrado	1/2"
Entrada de ar	1/4"
Torque de aperto	231Nm
Torque de desaperto	350Nm
Velocidade nominal	8500RPM
Consumo real de ar	4CFM (113L/min)
Pressão do trabalho	6,2BAR
Intensidade do som	88dB
Sistema de martelo	Jumbo
Velocidades	4
Golpes por minuto	1300
Peso	1,16Kg
Dimensões (CxLxA)	237x88x60mm

54859

264,00€



NEW

CHAVE DE IMPACTO 3/4" 2300 NM



VÍDEO TUTORIAL

Medida do quadrado	3/4"
Entrada de ar	1/2"
Torque de aperto	2000Nm
Torque de desaperto	2300Nm
Consumo real de ar	9CFM (255L/min)
Pressão do trabalho	5500RPM
Velocidade nominal	6,3BAR
Intensidade do som	108,9dB
Sistema de martelo	Doble/Twin
Velocidades	4
Golpes por minuto	900
Peso	4,25Kg
Dimensões (CxLxA)	228x90x217mm

51212

488,00€

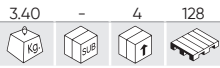

CHAVE DE IMPACTO 3/4" 2034NM



REPOSIÇÕES
DISPONÍVEIS

Medida do quadrado	3/4"
Entrada de ar	3/4"
Torque de aperto	1627Nm
Torque de desaperto	2034Nm
Velocidade nominal	5500RPM
Consumo real de ar	8CFM (226L/min)
Pressão do trabalho	6,2BAR
Intensidade do som	90dB
Sistema de martelo	Doble/Twin
Velocidades	6
Golpes por minuto	900
Peso	3,40Kg
Dimensões (CxLxA)	232x215x87mm

51211

560,00€



CHAVE DE IMPACTO 1" 2034NM



REPOSIÇÕES
DISPONÍVEIS

Medida do quadrado	1"
Entrada de ar	3/8"
Torque de aperto	1627Nm
Torque de desaperto	2034Nm
Velocidade nominal	5500RPM
Consumo real de ar	8CFM (226L/min)
Pressão do trabalho	6,2BAR
Intensidade do som	93dB
Sistema de martelo	Doble/Twin
Velocidades	6
Golpes por minuto	900
Peso	3,50Kg
Dimensões (CxLxA)	232x223x87mm

53681

743,00€

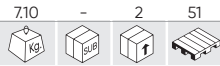

CHAVE DE IMPACTO ULTRALEVE 1" PARA CAMIÕES 2441 NM



REPOSIÇÕES
DISPONÍVEIS

Medida do quadrado	1"
Entrada de ar	1/2"
Torque de aperto	1965Nm
Torque de desaperto	2441Nm
Velocidade nominal	6000RPM
Consumo real de ar	10CFM (282L/min)
Pressão do trabalho	6,2BAR
Intensidade do som	90dB
Sistema de martelo	Doble/Twin
Velocidades	3
Peso	7,10Kg
Dimensões (CxLxA)	522x175x143mm

52814

528,00€

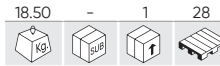

CHAVE DE IMPACTO 1" PARA CAMIÕES 3260 NM



REPOSIÇÕES
DISPONÍVEIS

Medida do quadrado	1"
Entrada de ar	1/2"
Torque de aperto	2180Nm
Torque de desaperto	3260Nm
Velocidade nominal	3600RPM
Consumo real de ar	14,7CFM (424L/min)
Pressão do trabalho	6BAR
Intensidade do som	108dB
Sistema de martelo	Doble/Twin
Velocidades	6
Peso	18,50Kg
Dimensões (CxLxA)	650x180x150mm



51210

650,00€

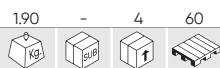

CHAVE DE IMPACTO DE 3/4" 2034NM + ALARGADOR 15CM



REPOSIÇÕES DISPONÍVEIS

Medida do quadrado	3/4"
Entrada de ar	3/8"
Torque de aperto	1627Nm
Torque de desaperto	2034Nm
Velocidade nominal	5500RPM
Consumo real de ar	8CFM (230L/min)
Pressão do trabalho	6,2BAR
Intensidade do som	90dB
Sistema de martelo	Doble/Twin
Velocidades	6
Golpes por minuto	900
Peso	1,90Kg
Dimensões (CxLxA)	368x232x87mm

51213

690,00€



CHAVE DE IMPACTO 1" 2034NM + ALARGADOR 19CM



REPOSIÇÕES DISPONÍVEIS

Medida do quadrado	1"
Entrada de ar	3/8"
Torque de aperto	1627Nm
Torque de desaperto	2034Nm
Velocidade nominal	5500RPM
Consumo real de ar	8CFM (226L/min)
Pressão do trabalho	6,2BAR
Intensidade do som	90dB
Sistema de martelo	Doble/Twin
Velocidades	6
Golpes por minuto	900
Peso	4,40Kg
Dimensões (CxLxA)	376x232x87mm

JBM RECOMENDA O USO DE SEUS ÓLEOS LUBRIFICANTES PARA OTIMIZAR O DESEMPENHO E AMPLIAR A VIDA ÚTIL DA FERRAMENTA

- ✓ 14534 ÓLEO PARA FERRAMENTA PNEUMÁTICA - 600ML
- ✓ 14560 ÓLEO PARA FERRAMENTA PNEUMÁTICA - 100ML



DESCUBRA PASSO A PASSO COMO FAZER CORRETAMENTE A MANUTENÇÃO DA SUA FERRAMENTA PNEUMÁTICA



Leia o código QR abaixo para aceder à nossa página de tutoriais em vídeo



ESTÃO DISPONÍVEIS PARA SI CONJUNTOS DE REPARAÇÃO PARA FERRAMENTAS PNEUMÁTICAS



Leia o código QR abaixo e escolha o conjunto que corresponde à sua ferramenta



51214

148,00€

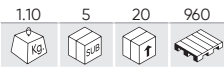

MINI ROQUETE 1/4" 40.7NM



REPOSIÇÕES
DISPONÍVEIS

Medida do quadrado	1/4"
Entrada de ar	1/4"
Torque de aperto	40,7Nm
Velocidade nominal	350RPM
Consumo real de ar	7,9CFM (138L/min)
Pressão do trabalho	6,2BAR
Intensidade do som	85dB
Peso	1,10Kg
Dimensões (CxLxA)	133x38x53mm

53784

148,00€

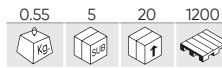

ROQUETE MINI DE 1/2" 40,8NM



REPOSIÇÕES
DISPONÍVEIS

Medida do quadrado	1/2"
Entrada de ar	1/4"
Torque de aperto	40,8Nm
Velocidade nominal	350RPM
Consumo real de ar	4CFM (113L/min)
Pressão do trabalho	6,2BAR
Intensidade do som	85dB
Peso	0,55Kg
Dimensões (CxLxA)	133x38x52mm

51215

119,00€

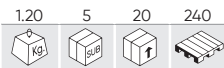

CATRACA DE 1/2" 68NM



REPOSIÇÕES
DISPONÍVEIS

Medida do quadrado	1/2"
Entrada de ar	1/4"
Torque de aperto	68Nm
Velocidade nominal	150RPM
Consumo real de ar	4CFM (113L/min)
Pressão do trabalho	6,2BAR
Intensidade do som	82,3dB
Peso	1,20Kg
Dimensões (CxLxA)	256x45x51mm

54336

259,00€



CATRACA ARTICULADA DE 1/2" 127NM



REPOSIÇÕES
DISPONÍVEIS

Medida do quadrado	1/2"
Entrada de ar	1/4"
Torque de aperto	95Nm
Torque de desaperto	127Nm
Velocidade nominal	150RPM
Consumo real de ar	7,9CFM (139L/Min)
Pressão do trabalho	6,2BAR
Intensidade do som	92dB
Peso	1,45Kg
Dimensões (CxLxA)	272x506x768mm



52167

48,00€

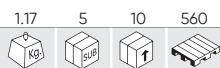

ROQUETE DE 1/2" 61NM



Medida do quadrado	1/2"
Entrada de ar	1/4"
Torque de aperto	61Nm
Velocidade nominal	150RPM
Consumo real de ar	4CFM (113L/min)
Pressão do trabalho	6,3BAR
Intensidade do som	95dB
Peso	1,17Kg
Dimensões (CxLxA)	263,5x56x41mm

51220

240,00€



BROCA REVERSÍVEL 1/2"



REPOSIÇÕES DISPONÍVEIS

Medida do quadrado	1/2"
Entrada de ar	1/4"
Velocidade nominal	800RPM
Consumo real de ar	4CFM (113L/min)
Pressão do trabalho	6,2BAR
Intensidade do som	83dB
Medidas da broca	Ø12,5mm
Peso	1,30Kg
Dimensões (CxLxA)	200x152x43mm

53573

36,00€

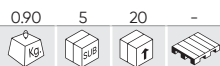

BERBEQUIM DIRETA



Medida do quadrado	3/8"
Entrada de ar	1/4"
Velocidade nominal	20000RPM
Consumo real de ar	4CFM (113L/min)
Pressão do trabalho	6,2BAR
Intensidade do som	89dB
Medidas da broca	Ø1,5-10mm
Peso	0,90Kg
Dimensões (CxLxA)	208,2x65,5x41,5mm

52159

64,00€

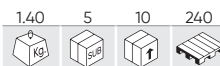

BERBEQUIM REVERSÍVEL DE 1/2"



Medida do quadrado	1/2"
Entrada de ar	1/4"
Velocidade nominal	700RPM
Consumo real de ar	4CFM (113L/min)
Pressão do trabalho	6,2BAR
Intensidade do som	86dB
Medidas da broca	Ø12,5mm
Peso	1,40Kg
Dimensões (CxLxA)	212,8x149,4x42mm

52527 **82,00€**

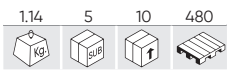

BERBEQUIM 3/8" ÂNGULO 90°

Medida do quadrado	3/8"
Entrada de ar	1/4"
Velocidade nominal	1500RPM
Consumo real de ar	4CFM (113L/min)
Pressão do trabalho	6,3BAR
Intensidade do som	86dB
Medidas da broca	Ø0,5-9,5mm
Peso	1,14Kg
Dimensões (CxLxA)	207,8x124,7x42,5mm



52160 **48,00€**

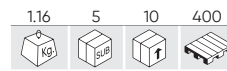

BERBEQUIM REVERSÍVEL DE 3/8"

Medida do quadrado	3/8"
Entrada de ar	1/4"
Velocidade nominal	1800RPM
Consumo real de ar	4CFM (113L/min)
Pressão do trabalho	6,2BAR
Intensidade do som	86dB
Medidas da broca	Ø9,5mm
Peso	1,16Kg
Dimensões (CxLxA)	194,3x149,4x42mm

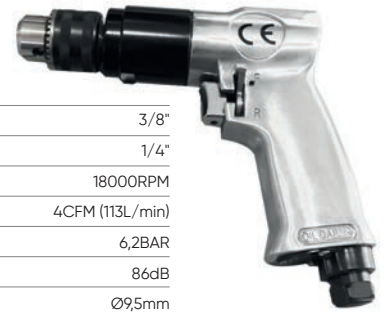

54794 **84,50€**

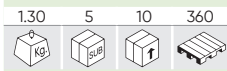

NEW

TESOURA PNEUMÁTICA METÁLICA

Entrada de ar	1/4"
Velocidade nominal	1800RPM
Consumo real de ar	114L/min
Intensidade do som	85dB
Capacidade de corte	1,2mm
Peso	1,30Kg



52574 **69,00€**

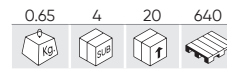

SERRA 1/4", 9000 RPM

Entrada de ar	1/4"
Velocidade nominal	9000RPM
Consumo real de ar	6CFM (170L/min)
Pressão do trabalho	6,2BAR
Intensidade do som	89dB
Capacidade de corte	1,6-2mm
Peso	0,65Kg
Dimensões (CxLxA)	236x71x40mm



REPOSIÇÕES DISPONÍVEIS



52953 **38,00€**

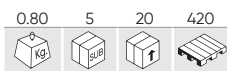

MOINHO DE 3" 18000RPM

Entrada de ar	1/4"
Velocidade nominal	18000RPM
Consumo real de ar	4CFM (113L/min)
Pressão do trabalho	6,2BAR
Intensidade do som	84dB
Diâmetro do disco	3"
Capacidade de corte	25mm
Peso	0,80Kg
Dimensões (CxLxA)	186x80,8x66,3mm



REPOSIÇÕES DISPONÍVEIS



54556 **74,00€**

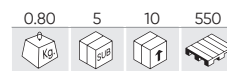

LIXADEIRA DE CINTA 3/8"

Entrada de ar	1/4"
Velocidade nominal	18000RPM
Consumo real de ar	113L/min
Pressão do trabalho	6,2BAR
Intensidade do som	89dB
Órbita de lixamento	10x330mm
Órbita de lixamento	60x80x120mm
Ângulo	90°
Peso	0,80Kg
Dimensões (CxLxA)	290x100x50mm



REPOSIÇÕES DISPONÍVEIS



52171

39,00€

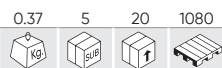

MINI AMOLADORA 1/4"



Diâmetro da pinça	1/4", 1/8", 3, 6mm
Entrada de ar	1/4"
Velocidade nominal	25000RPM
Consumo real de ar	4CFM (113L/min)
Pressão do trabalho	6,2BAR
Intensidade do som	93dB
Diâmetro do eixo	1/4"
Peso	0,37Kg
Dimensões (CxLxA)	121x51x34mm

51245

99,00€



MINI AMOLADORA DE 3/8"



REPOSIÇÕES DISPONÍVEIS

Tamanho do eixo	3/8"
Entrada de ar	1/4"
Velocidade nominal	25000RPM
Consumo real de ar	4CFM (113L/min)
Pressão do trabalho	6,3BAR
Intensidade do som	77dB
Peso	0,40Kg
Dimensões (CxLxA)	159x39x63mm

53137

38,00€

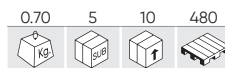

MINI-REBARBADORA DE 1/4"



Medida do quadrado	1/4"
Entrada de ar	1/4"
Velocidade nominal	25000RPM
Consumo real de ar	85L/min
Pressão do trabalho	6,2BAR
Intensidade do som	101dB
Diâmetro do disco	3-6mm
Peso	0,70Kg
Dimensões (CxLxA)	155x39x65mm

53141

73,00€

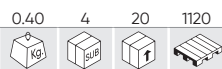

REBARBADORA ANGULAR DE 1/4"



Medida do quadrado	1/4"
Entrada de ar	1/4"
Velocidade nominal	18000RPM
Consumo real de ar	3CFM (86L/min)
Pressão do trabalho	6,2BAR
Intensidade do som	99dB
Diâmetro do eixo	6mm
Peso	0,40Kg
Dimensões (CxLxA)	150x50x85mm

52528

49,00€

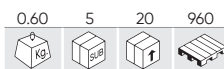

AMOLADORA ANGULAR 1/4"



Medida do quadrado	1/4"
Entrada de ar	1/4"
Velocidade nominal	20000RPM
Consumo real de ar	4CFM (113L/min)
Pressão do trabalho	6,2BAR
Intensidade do som	91dB
Diâmetro do eixo	1/4"
Ângulo	90°
Peso	0,60Kg
Dimensões (CxLxA)	165x77x37mm

51216

650,00€



KIT PULIDORA 1/4"



REPOSIÇÕES DISPONÍVEIS

Entrada de ar	1/4"
Velocidade nominal	3500RPM
Consumo real de ar	10CFM (283L/min)
Pressão do trabalho	6,2BAR
Intensidade do som	83dB
Diâmetro do disco	11-23mm
Peso	1,20Kg
Dimensões (CxLxA)	272x70x203mm

53626

18,00€

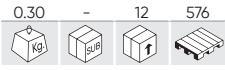

KIT DE RESTAURAÇÃO DE FARÓIS



EM EXPOSITOR DE 12 UDS

	x2	Ep800 discos de lixar
	x2	P1200 discos de lixar
	x2	P2000 discos de lixar
	x2	3.0ml liquido protetor uv
	x2	Adaptador (3/8" & 1/4")
	x1	85gm pasta de polimento
	x1	Fita adesiva
	x1	Disco de polimento de lã
	x1	Disco de esponja branco

53646

69,00€

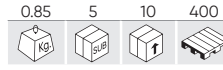

3" CONJUNTO PARA A MÁQUINA DE POLIMENTO



REPOSIÇÕES DISPONÍVEIS

Entrada de ar	1/4"
Velocidade nominal	3200RPM
Consumo real de ar	3,5CFM (99L/min)
Pressão do trabalho	6,2BAR
Intensidade do som	88dB
Diâmetro do eixo	16,8mm
Diâmetro do disco	3"
Peso	0,85Kg
Dimensões (CxLxA)	209,6x80x121,2mm

52676

99,00€

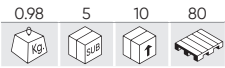

LIXADEIRA ORBITAL AUTO-ASPIRANTE

Entrada de ar	1/4"
Velocidade nominal	10500RPM
Consumo real de ar	3,5CFM (99L/min)
Pressão do trabalho	90PSI
Intensidade do som	6,2BAR
Diâmetro do disco	150mm
Órbita de lixamento	15 Agujeros/Holes
Órbita de lixamento	5mm
Ângulo	90°
Peso	0,98Kg
Dimensões (CxLxA)	223,3x147,5x105,9mm



REPOSIÇÕES DISPONÍVEIS



PÁGINA 193

Descubra a variedade de acessórios que temos para você:
Discos de lixa



52675

89,00€

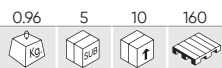

LIXADEIRA ORBITAL ADAPTÁVEL ASPIRADOR 5MM

Entrada de ar	1/4"
Velocidade nominal	10500RPM
Consumo real de ar	3,5CFM (99L/min)
Pressão do trabalho	6,3BAR
Intensidade do som	90dB
Diâmetro do disco	150mm
Órbita de lixamento	15 Agujeros/Holes
Órbita de lixamento	5mm
Ângulo	90°
Peso	0,96Kg



52758

89,00€

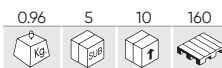

PULIDORA

Entrada de ar	1/4"
Velocidade nominal	10500RPM
Consumo real de ar	3,5CFM (99L/min)
Pressão do trabalho	6,2BAR
Intensidade do som	90dB
Diâmetro do disco	150mm
Órbita de lixamento	15 Agujeros/Holes
Órbita de lixamento	2,5mm
Ângulo	90°
Peso	0,96Kg



54251

43,00€

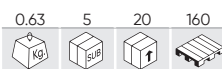

PISTOLA DE SOPRO E ASPIRAÇÃO

Entrada de ar	1/4"
Consumo real de ar	4,4CFM (96L/min)
Pressão do trabalho	6,2BAR
Diâmetro	3/8"-10mm
Comprimento	1450mm
Peso	0,63Kg



VIDEO TUTORIAL

53611

27,50€

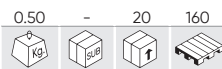

PISTOLA DE AR EXTRA-LONGA



Entrada de ar	1/4"
Pressão do trabalho	11,7BAR
Comprimento	1020mm
Peso	0,50Kg

52798

18,00€

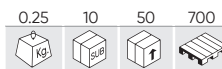

PISTOLA DE AR EXTENSÍVEL



Entrada de ar	1/4"
Pressão do trabalho	11,7BAR
Comprimento	285-530mm
Peso	0,25Kg

52490

6,65€

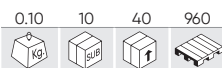

PISTOLA DE AR 100MM

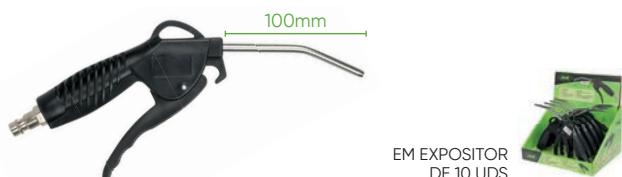

Entrada de ar	1/4"
Pressão do trabalho	8,2BAR
Comprimento	100mm
Peso	0,10Kg

52491

10,50€



PISTOLA DE AR 300MM



Entrada de ar	1/4"
Pressão do trabalho	8,3BAR
Comprimento	300mm
Peso	0,15Kg

52787

9,00€

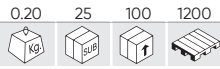

PISTOLA DE AR

Entrada de ar	1/4"
Pressão do trabalho	8,3BAR
Comprimento	260mm
Peso	0,20Kg



51383

11,60€

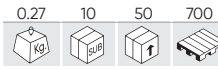

PISTOLA DE AR (EM BLISTER)

Entrada de ar	1/4"
Pressão do trabalho	8BAR
Comprimento	150mm
Peso	0,27Kg



EM EXPOSITOR DE 10 UDS

53205

22,50€

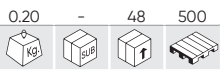

PISTOLA DE SOPRO DE GRANDE CAUDAL



Entrada de ar	1/4"
Pressão do trabalho	6,2BAR
Peso	0,20Kg
Dimensões (CxLxA)	160x30x100mm

52381

20,50€

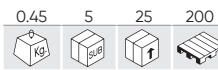

PISTOLA DE AR DE 3/8" COM MANGUEIRA DE 5M



Entrada de ar	3/8"
Pressão do trabalho	8,3BAR
Comprimento	5m
Peso	0,45Kg

51277

68,00€

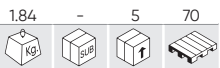

KIT DE FERRAMENTAS PNEUMÁTICAS



PUNHO DE PISTOLA INFLADOR DE AR COM MEDIDOR	
Pressão de trabalho:	0-16BAR
Entrada de ar:	1/4"
Comprimento da mangueira:	330mm
PISTOLA DE AR COMPRIMIDO	
Pressão de trabalho:	0-12BAR
Entrada de ar:	1/4"
PISTOLA DE LAVAGEM DO MOTOR COM TANQUE PARA SOLUÇÃO DE LIMPEZA	
Máx. pressão:	10BAR
Entrada de ar:	1/4"
Capacidade:	600CC
Pot Material:	De aço
Material do corpo:	Liga de alumínio
Superfície:	Pó Revestido

SPRIAL HOSE	
Dimensão:	5x8mm
Comprimento máx. máximo:	4.5m
Entrada de ar:	1/4"
PISTOLA DE PINTURA POR GRAVIDADE COM TANQUE	
Consumo de ar:	0.3-0.5MPa
Diâmetro do bocal:	1.5mm
Capacidade do tanque:	600ml

51981

23,50€

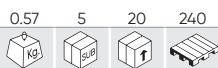

PISTOLA DE AR+PISTOLA PARA PNEUMÁTICOS

Entrada de ar	1/4"
Pressão do trabalho	12BAR
Comprimento	320mm
Peso	0,58Kg



51980

15,00€

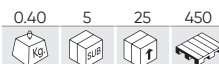

PISTOLA DE AR PARA PNEUMÁTICOS

Entrada de ar	1/4"
Pressão de trabalho máxima	16BAR
Comprimento	330mm
Peso	0,40Kg



54248

62,00€

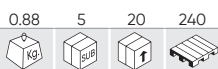

PISTOLA DE PINTURA



REPOSIÇÕES DISPONÍVEIS



Entrada de ar	1/4"
Consumo real de ar	10CFM (283L/min)
Fluxo de ar	6-10 scfm
Pressão do trabalho	30BAR
Capacidade do tanque	600ml
Taxa de fluxo máxima	100-190mL/min
Capacidade de pulverização	160-240mm
Peso	0,88Kg

54249

110,00€



PISTOLA DE PINTURA PROFISSIONAL



REPOSIÇÕES DISPONÍVEIS



Entrada de ar	1/4"
Consumo real de ar	10CFM (283L/min)
Fluxo de ar	6-10 scfm
Pressão do trabalho	30BAR
Capacidade do tanque	600ml
Taxa de fluxo máxima	190ml/min
Capacidade de pulverização	180-260mm
Diâmetro	1,4mm
Peso	0,98Kg

53449

18,00€

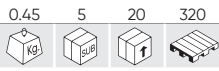

PISTOLA DE ENCHIMENTO ANALÓGICA



Entrada de ar	1/4"
Pressão de trabalho máxima	6,9BAR
Unidades de medida	PSI / BAR
Comprimento	200mm
Peso	0,45Kg

53450

28,30€

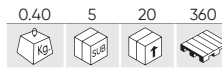

PISTOLA DE ENCHIMENTO DIGITAL



Entrada de ar	1/4"
Pressão de trabalho máxima	13,8BAR
Unidades de medida	PSI / BAR / KPA / KG/CM2
Comprimento	300mm
Peso	0,40Kg

MEDIDORES DE PRESSÃO

REF.	DESCRIÇÃO					€
52648	MEDIDOR DE PRESSÃO DOS PNEUS	0.08	5	100	2000	9,00€
53416	MEDIDOR DE PRESSÃO DE PNEUMÁTICOS COM TUBO (0-10BAR)	0.20	10	100	800	15,50€
53417	MEDIDOR DE PRESSÃO DE PNEUMÁTICOS DIGITAL COM TUBO (0-15BAR)	0.25	10	100	800	27,50€
53418	MEDIDOR DE PRESSÃO DE PNEUMÁTICOS DIGITAL (0-15BAR)	0.20	10	100	800	18,10€



52648



53416



53417



53418

53625

68,00€

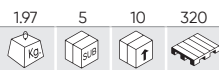

MARTELO DE AGULHAS PNEUMÁTICO

Entrada de ar	1/4"
Faixa	6,2BAR
Abertura	350mm
Peso	1,97Kg
Dimensões (CxLxA)	260x185x57mm



51861

199,00€

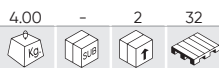

MÁQUINA PNEUMÁTICA P/MONTAR FOLAS DE TRANSMISSÕES

Entrada de ar	1/4"
Pressão do trabalho	9BAR
Material	Aluminio/Aluminum
Abertura	20-100mm
Peso	4,00Kg
Dimensões (CxLxA)	200x200x450mm



54888

239,00€

9.50 - 1 49

NEW

MARTELO PNEUMÁTICO MULTIFUNÇÃO - 25 PEÇAS

Tamanho do eixo	3/4"
Entrada de ar	1/4"
Consumo real de ar	4CFM (113L/min)
Pressão do trabalho	6,3BAR
Intensidade do som	110dB
Golpes por minuto	4500
Contém	Cinceles, extractores de rótula/Chisels, Ball-joint extractors
Peso	9,50Kg
Dimensões (CxLxA)	470x320x125mm



52718

48,00€

1.95 4 8 160

ESTOJO DE 9 PEÇAS COM MARTELO PNEUMÁTICO DE 1/2"

Medida do quadrado	1/2"
Entrada de ar	1/4"
Velocidade nominal	4500RPM
Consumo real de ar	4CFM (113L/min)
Pressão do trabalho	6,3BAR
Intensidade do som	103dB
Medidas da broca	Ø12,5mm
Golpes por minuto	4500
Contém	Cinceles/Chisels
Peso	1,95Kg
Dimensões (CxLxA)	15x150x49mm



52540

221,00€

4.36 - 1 60

VENTOSA PNEUMÁTICA COM MARTELO DESLIZANTE

Peças	5
Resistência	7,6BAR
Diâmetro	75, 100, 125mm
Comprimento	620mm
Peso	4,36Kg
Dimensões (CxLxA)	620x250x100mm



53542

980,00€

4.60 - 4 40

DESTANOLADOR PNEUMÁTICO DE PNEUS

Consumo real de ar	4CFM (113L/min)
Pressão do trabalho	6,2BAR
Velocidade	10000RPM
Entrada de ar	1/4"
Mangueira	3/8"
Abertura	68mm
Percurso	80mm
Material	S, Al
Peso	4,60Kg
Dimensões (CxLxA)	396x320x160mm



REPOSIÇÕES DISPONÍVEIS

54255 74,00€

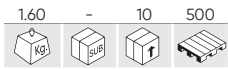

CONJUNTO COMPLETO DE ACESSÓRIOS PISTOLA DE LUBRIFICAÇÃO



Peças	7
Extensão de mangueira	300mm
Adaptadores	90-360°
Peso	1,60Kg
Dimensões (CxLxA)	260x170x60mm

50751 44,00€

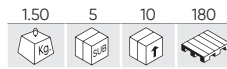

BOMBA DE MASSA PNEUMÁTICA



Entrada de ar	1/4"
Capacidade	500ml
Pressão do trabalho	6,2BAR
Pressão máxima	30Mpa
Peso	1,50Kg

52543 182,00€

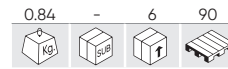

PISTOLA LIMPIADORA DE FILTROS DE PARTÍCULAS



Entrada de ar	1/4"
Faixa	3-7BAR
Capacidade	650cc
Compatível com	90003, 90004
Peso	0,84Kg
Dimensões (CxLxA)	165x89x260mm

52575 119,00€

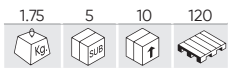

REBITADOR PNEUMÁTICO



REPOSIÇÕES DISPONÍVEIS

Entrada de ar	1/4"
Adaptadores	3/16", 5/32", 1/8", 3/32"
Consumo real de ar	0,03CFM (0,86L/min)
Tração	720,00Kg
Binário máximo	23-69Nm
Peso	1,75Kg
Dimensões (CxLxA)	85x175x280mm

53593 41,00€



PISTOLA DE JACTO DE AREIA PNEUMÁTICA



REPOSIÇÕES DISPONÍVEIS

Entrada de ar	1/4"
Faixa	8BAR
Consumo real de ar	6,5CFM (184L/min)
Peso	0,65Kg
Dimensões (CxLxA)	238x110x160mm

53204 81,00€

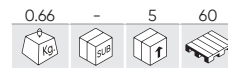

PISTOLA DE LIMPEZA TORNADO



Entrada de ar	1/4"
Faixa	9,1BAR
Consumo real de ar	8-10CFM (227-283L/min)
Peso	0,66Kg
Dimensões (CxLxA)	325x120x235mm

53202 15,70€

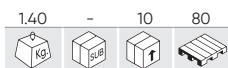

PISTOLA DE PETROLEADO



Entrada de ar	1/4"
Pressão do trabalho	10BAR
Capacidade	900cc
Peso	1,40Kg
Dimensões (CxLxA)	205x110x375mm

53572 348,00€



FERRAMENTA PNEUMÁTICA PARA POLIMENTO DE VÁLVULAS - PERCUSSÃO E ROTAÇÃO



REPOSIÇÕES DISPONÍVEIS



Peças	12
RPM (rotações por minuto)	800
Entrada de ar	1/4"
Consumo real de ar	1,80CFM (51L/min)
Peso	1,90Kg
Dimensões (CxLxA)	283x87x70mm

53567

43,00€

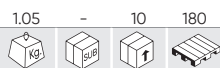

PISTOLA DE SILICONE PNEUMÁTICA 310ML



REPOSIÇÕES DISPONÍVEIS

Entrada de ar	1/4"
Pressão do trabalho	2,5-5BAR
Capacidade	310ml
Peso	1,05Kg
Dimensões (CxLxA)	305x185x65mm

52533

10,00€

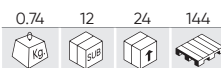

PISTOLA SILICONE 300ML



Capacidade	300ml
Peso	0,74Kg
Dimensões (CxLxA)	360x215x60mm

54514

109,00€



BOMBA PNEUMÁTICA/MANUAL PARA EXTRAÇÃO DE ÓLEO 6.5L



Capacidade	6,5L
Pressão do trabalho	2,76-11,72BAR
Entrada de ar	1/4"
Temperatura de trabalho	2/80°C
Peso	3,50Kg
Dimensões (CxLxA)	225x215x565mm

54555

149,00€

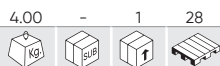

BOMBA DE TRANSMISSÃO PNEUMÁTICA 10L COM 15 ADAPTADORES



Capacidade	10L
Mangueiras	4
Adaptadores	15
Pressão do trabalho	2,8-11,7BAR
Entrada de ar	1/4"
Temperatura de trabalho	-3/140°C
Peso	4,00Kg
Dimensões (CxLxA)	280x245x530mm

90003

35,20€

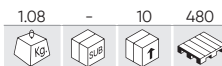

LÍQUIDO DESCARBONIZANTE



90004

25,80€

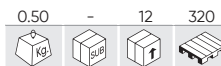

LÍQUIDO NEUTRALIZANTE



53147

41,00€

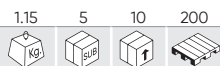

EXPOSITOR DE FERRAMENTA PNEUMÁTICA



Peso	1,15Kg
Dimensões (CxLxA)	350x250x30mm

53492

380,00€



EXPOSITOR DE FERRAMENTA PNEUMÁTICA



EXPOSITOR SEM FERRAMENTAS

Peso	13,00Kg
Dimensões (CxLxA)	970x530x240mm



52378 10,00€

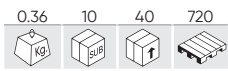

GANCHO MAGNÉTICO

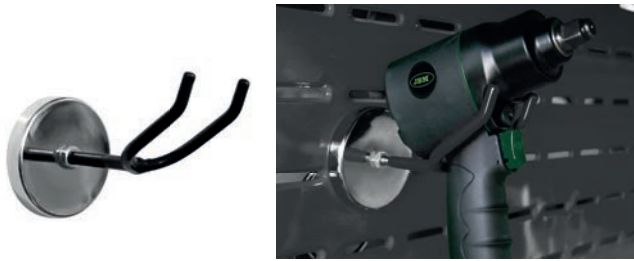

51341 37,00€

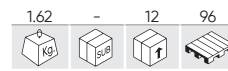

COLGADOR IMANTADO PARA FERRAMENTA PNEUM



DISCOS DE CORTE

REF.	DESCRIÇÃO	COMPATIBILIDADE					€
51385	DISCO CORTE DE 4"X1/32"	51219	0.01	10	300	800	4,95€
51387	DISCO DE CORTE DE 3"	51227	0.03	10	300	800	3,65€

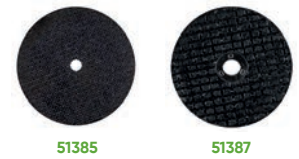

DISCOS LIXA

REF.	DESCRIÇÃO	COMPATIBILIDADE					€
51386	DISCO LIXA DE 5"	51218	0.10	-	25	800	8,50€
51443	DISCO DE LIXA #60	51226	0.50	25	150	800	6,50€
51444	DISCO DE LIXA #80	51226	0.02	-	25	800	7,00€
51445	DISCO DE LIXA #120	51226	0.02	-	25	800	5,70€



DISCO PARA LIXADEIRAS

REF.	DESCRIÇÃO	COMPATIBILIDADE					€
13499	DISCO DE 15 BURACOS PARA LIXADEIRAS	52675	0.10	-	50	1500	12,50€
13500	DISCO DE 66 BURACOS PARA LIXADORAS	52676	0.65	5	50	-	12,90€
12009	DISCO DE 6 BURACOS PARA LIXADEIRAS	52758	0.14	-	50	-	11,00€



FILTRO E REGULADOR DE AR

REF.	"					€
53063	1/4"	0.63	5	50	300	37,00€
53064	3/8"	0.63	5	50	300	37,40€
53065	1/2"	0.60	5	50	300	39,00€



FILTRO, REGULADOR DE AR E LUBRIFICADOR

REF.	"					€
53066	1/4"	1.08	5	25	250	61,00€
53067	3/8"	1.08	5	25	250	61,00€
53068	1/2"	1.00	5	25	250	63,00€



14534

18,80€

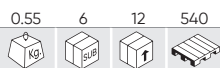

ÓLEO PARA FERRAMENTA PNEUMÁTICA - 600ML



Capacidade	600ml
Viscosidade	12,1/40°C
Densidade relativa a 15°C	0,845

14560

8,80€

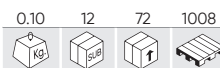

ÓLEO PARA FERRAMENTA PNEUMÁTICA - 100ML



EM EXPOSITOR DE 12 UDS



Capacidade	100ml
Viscosidade	12,1/40°C
Densidade relativa a 15°C	0,845

53594

58,00€

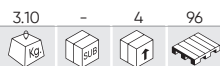

MANGUEIRA DE AR 8MM - 25M



REPOSIÇÕES DISPONÍVEIS

Pressão de trabalho máxima	20BAR
Diâmetro interior	8mm
Diâmetro exterior	13mm
Comprimento	25M
Temperatura de trabalho	-40/65°C
Compatível com	52736
Peso	3,10Kg

53595

61,00€



MANGUEIRA DE AR 10MM - 25M



REPOSIÇÕES DISPONÍVEIS

Pressão de trabalho máxima	20BAR
Diâmetro interior	10mm
Diâmetro exterior	15mm
Comprimento	25M
Temperatura de trabalho	-40/65°C
Compatível com	52737
Peso	3,20Kg

54792

30,50€



NEW

MANGUEIRA DE AR DE 10 M 10 MM



Adaptadores	1/4"
Pressão de trabalho máxima	20BAR
Diâmetro interior	10mm
Diâmetro exterior	15mm
Material	PVC
Cor	Verde alta visibilidad/ High visibility green
Resistente aos raios UV	Si/Yes
Comprimento	10M
Temperatura de trabalho	-40°C + 70°C
Peso	1,60Kg

54793

50,00€



NEW

MANGUEIRA DE AR DE 20 M 10 MM



Adaptadores	1/4"
Pressão de trabalho máxima	20BAR
Diâmetro interior	10mm
Diâmetro exterior	15mm
Material	PVC
Cor	Verde alta visibilidad/ High visibility green
Resistente aos raios UV	Si/Yes
Comprimento	20M
Temperatura de trabalho	-40°C + 70°C
Peso	3,40Kg

CARRETEL DE MANGUEIRA DE AR

REF.	m	"	Pressão do trabalho	Pressão de ruptura	Ø	kg	cm	cm	cm	cm	cm	€
53582	22m	3/8"	10BAR/150PSI	30BAR/450PSI	9.5mm	10.40	-	1	14	174,00€		
53583	22m	3/8"	10BAR/150PSI	30BAR/450PSI	9.5mm	10.75	-	1	14	174,00€		
53532	13m	3/8"	10BAR/150PSI	30BAR/450PSI	9.5mm	6.60	-	2	30	119,00€		
53581	13m	3/8"	10BAR/150PSI	30BAR/450PSI	9.5mm	6.70	-	2	36	119,00€		
53881	11,5m	1/4"	10BAR/150PSI	30BAR/450PSI	8mm	4.50	-	4	48	79,00€		
53882	11,5m	1/4"	10BAR/150PSI	30BAR/450PSI	8mm	4.50	-	4	48	79,00€		



COM REPARTIDOR



COM ALÇA



COM ACOPLAMENTO



53582 - 53583 53532-53581-53881-53882

COM SUPORTE DE PAREDE



50797

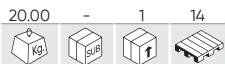

490,00€

CARRETEL DE MANGUEIRA PARA ÓLEO 15+1 M, 1/2"

Comprimento do tubo	15+1m
Pressão do trabalho	180BAR
Pressão de ruptura	540BAR
Conectores	1/2" BSPT
Diâmetro	12,7mm
Material	Açero/Steel
Peso	19,00Kg
Dimensões (CxLxA)	640x255x630mm



MANGUEIRA ESPIRAL PNEUMÁTICA

REF.	m	Ø	Ø	"	kg	cm	cm	cm	cm	€
53629	10m	8mm	5mm	1/4"	0.55	-	6	426	14,90€	
53630	15m	8mm	5mm	1/4"	0.65	-	6	240	21,00€	
53631	15m	12mm	8mm	1/4"	1.25	-	6	108	35,50€	
53632	15m	15mm	10mm	1/4"	2.20	-	6	78	49,50€	
53633	15m	15mm	10mm	3/8"	2.10	-	6	78	49,50€	
53634	15m	18mm	13mm	1/2"	2.60	-	6	66	69,00€	



53629

53630

53631

53632

53633

53634



CONECTOR / ROSCA





US

MACHO
FÊMEA

REF.	PCS	"	[ 				€
13930	1	1/4"	♂ ♂	0.01	50	100	1,55€
13932	1	3/8"	♂ ♂	0.07	50	100	2,50€
14076	1	3/8"	♂ ♀	0.10	50	100	1,70€
13933	1	1/2"	♂ ♂	0.06	50	100	2,00€
13935	2	1/4"	♂ ♀	0.05	50	100	2,50€
13936	1	1/4"	♀ ♀	0.10	50	100	4,15€
13937	1	1/4"	♀ ♂	0.07	50	100	4,20€
14078	1	3/8"	♀ ♀	0.10	50	100	4,45€
14191	1	1/2"	♂ ♀	0.04	50	100	2,00€
14193	1	1/2"	♀ ♀	0.10	50	100	4,50€







EUR

REF.	PCS	"	[ 				€
13931	2	1/4"	♂ ♂	0.02	50	100	2,50€
14075	1	3/8"	♂ ♀	0.10	50	100	2,00€
13934	2	1/4"	♂ ♀	0.02	50	100	2,50€
13938	1	1/4"	♀ ♀	0.10	50	200	4,05€
13939	1	1/4"	♀ ♂	0.07	50	100	4,05€
14077	1	3/8"	♀ ♀	0.10	50	100	4,50€
14190	1	1/2"	♂ ♀	0.04	50	100	2,00€
14192	1	1/2"	♀ ♀	0.10	50	100	4,45€



CONECTOR UNIVERSAL DE SEGURANÇA PARA MANGUEIRA

REF.	DESCRIÇÃO					€
14201	1/4" - M6	0.10	25	100	-	4,30€
14202	1/4" - M8	0.10	25	100	-	4,35€
14203	1/4" - M10	0.10	25	100	-	4,85€











CONECTOR DE MANGUEIRA

REF.	DESCRIÇÃO					€
14204	EUR - M6 M 1/4"	0.06	50	200	-	1,50€
14205	EUR - M8 M 3/8"	0.06	50	200	2000	1,50€
14206	EUR - M10 M 1/2"	0.05	50	200	-	1,50€
14207	US - M6 M 1/4"	0.05	50	200	-	1,50€
14208	US - M8 M 3/8"	0.06	50	200	-	1,50€
14209	US - M10 M 1/2"	0.05	50	200	-	1,50€



CONECTOR DE SEGURANÇA UNIVERSAL

REF.	"							€
14195	1/4"	♀	♂	0.20	25	100	-	4,30€
14196	3/8"	♀	♂	0.10	25	100	-	4,30€
14197	1/2"	♀	♂	0.10	25	100	-	4,50€
14198	1/4"	♀	♀	0.10	25	100	-	4,05€
14199	3/8"	♀	♀	0.10	25	100	-	4,00€
14200	1/2"	♀	♀	0.10	25	100	2400	4,85€

MACHO 
FÊMEA 



CONECTOR ARTICULADO MACHO PARA AR COMPRIMIDO EURO

REF.	DESCRIÇÃO					€
14314	EUR - 1/4"	0.05	25	100	-	5,20€
14315	US - 1/4"	0.06	25	100	-	5,60€



14561





0.05	25	50	-
------	----	----	---

CONECTOR LUBRIFICANTE 1/4"

8,80€







ENGATE RÁPIDO PNEUMÁTICO

REF.	DESCRIÇÃO					€
52735	1/4" - M6	0.05	25	200	4000	5,20€
52736	1/4" - M8	0.10	25	200	4000	5,70€
52737	1/4" - M10	0.07	25	200	4000	5,90€



ADAPTADOR ARTICULADO

REF.	DESCRIÇÃO					€
12988	ADAPTADOR ARTICULADO PNEUMÁTICO DE 1/2"	0.15	62	125	-	20,50€
13809	ADAPTADOR ARTICULADO 1/4"	0.10	-	100	-	12,00€
13810	ADAPTADOR ARTICULADO 3/8"	0.10	62	250	-	18,50€



54341

643,00€

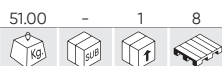

MÁQUINA DE JACTO DE AREIA 220L



VÍDEO TUTORIAL



REPOSIÇÕES DISPONÍVEIS



Tensão	100-240V
Capacidade do depósito	220L
Capacidade de carga de areia	33L
Granulometria recomendada	60-80MESH
Taxa de fluxo de ar	40-120PSI
Peso	51,00Kg
Capacidade do depósito	860x560x560mm
Dimensões (CxLxA)	1390x905x632mm

54563

298,00€



MÁQUINA DE JACTO DE AREIA 90L



VÍDEO TUTORIAL



REPOSIÇÕES DISPONÍVEIS



Tensão	12V
Capacidade do depósito	90L
Capacidade de carga de areia	6,5L
Granulometria recomendada	60-80MESH
Taxa de fluxo de ar	40-120PSI
Peso	19,30Kg
Capacidade do depósito	580x480x305mm
Dimensões (CxLxA)	580x485x494mm

54865

439,00€

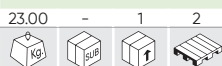

NEW

TANQUE PORTÁTIL DE JATEAMENTO DE AREIA DE ALTA PRESSÃO – 63L



Capacidade	63L
Consumo real de ar	6-25 CFM
Pressão do trabalho	60-125 PSI
Comprimento da mangueira de alta pressão	2,4M
Peso	23,00Kg
Dimensões (CxLxA)	880x460x420mm

54866

1.690,00€

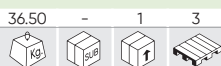

NEW

TANQUE PORTÁTIL DE LIMPEZA DE CARVÃO POR JATEAMENTO DE AREIA – 18 L



Potência da bomba de vácuo	1200W
Fluxo de trabalho	1-2 L/min
Consumo real de ar	158-165 L/min
Pressão do trabalho	90-125 PSI
Capacidade do depósito	18L
Comprimento da mangueira	3M
Capacidade máxima de vácuo	15L

54867

840,00€



NEW

MÁQUINA DE JATEAMENTO DE AREIA COM SISTEMA DE SUÇÃO E VÁCUO – 17 L



Potência da bomba de vácuo	1200W
Tensão	230V / 50Hz
RPM (rotações por minuto)	16000RPM
Fluxo de ar	6-22.5 CFM
Pressão do trabalho	90-120 PSI
Capacidade do depósito	17L
Dimensões do depósito	381x381x1041mm
Peso	36,00Kg

FERRAMENTAS DE IMPACTO

200 CHAVES DE CAIXA DE IMPACTO

204 ESPECIAL PNEUS

206 ADAPTADORES

207 PEÇAS SOBRESSALENTES

209 ESPECIAL CAMINHÕES



52694

49,50€

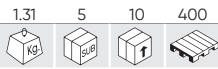

KIT DE 3 CHAVES XZN DE 1/2" DE IMPACTO



1/2" x3 78mmL 30, 32, 36mm

52337

69,00€

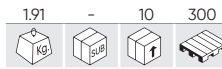

KIT DE 6 CHAVES DE IMPACTO DE 1/2"



1/2" x3 80mmL 30, 32, 36mm
 1/2" x3 43mmL 14, 17, 19mm

52547

96,00€

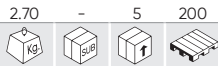

KIT DE 8 CHAVES E PUNTAS XZN DE IMPACTO DE 1/2"



REPOSIÇÕES DISPONÍVEIS



1/2" x5 78mmL 27, 30, 32, 34, 36mm
 1/2" x3 45mmL M14, M16, M18

54806

96,00€

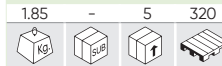

NEW

CONJUNTO DE 5 CHAVES HEXAGONAIS E 3 CHAVES DE IMPACTO XZN 1/2"



REPOSIÇÕES DISPONÍVEIS



1/2" x5 78mmL 27, 30, 32, 34, 36mm
 1/2" x3 45mmL M14, M16, M18

53531

111,00€



SET 19 PEÇAS DE IMPACTO DE 1/2" COM 14 VASOS DE 12 CANTOS + ADAPTADORES



REPOSIÇÕES DISPONÍVEIS



1/2" x14 78mmL 10, 11, 12, 13, 14, 15, 16, 17, 18, 19, 21, 22, 24, 27mm
 1/2" x3 50, 150, 250mm
 1/2" x1 ADAPTADOR DE IMPACTO 1/2" F 3/4" M
 1/2" x1 ARTICULAÇÃO UNIVERSAL DE IMPACTO DE 1/2"

52345

109,00€



KIT DE 19 CHAVES DE IMPACTO DE 1/2" HEX + ADAPTADOR



REPOSIÇÕES DISPONÍVEIS



1/2" x14 78mmL 10, 11, 12, 13, 14, 15, 16, 17, 18, 19, 21, 22, 24, 27mm
 1/2" x3 50, 150, 250mm
 1/2" x1 ADAPTADOR DE IMPACTO 1/2" F 3/4" M
 1/2" x1 ARTICULAÇÃO UNIVERSAL DE IMPACTO DE 1/2"

52341 59,00€

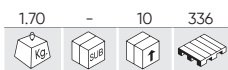

KIT DE 13 CHAVES DE IMPACTO DE 1/2" HEX. + ADAPTADOR



REPOSIÇÕES DISPONÍVEIS



		1/2"	x10	38mmL	10, 11, 12, 13, 14, 17, 19, 21, 22, 24mm
		1/2"	x1	125mm	
		1/2"	x1	AUMENTO DE IMPACTO DE 125MM	1/2"
		1/2"	x1	ARTICULAÇÃO UNIVERSAL DE IMPACTO DE 1/2"	

52346 110,00€

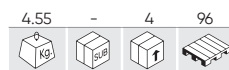

KIT DE 12 CHAVES DE IMPACTO COMPRIDOS DE 1/2"



REPOSIÇÕES DISPONÍVEIS



		1/2"	x12	78mmL	10, 12, 13, 15, 16, 17, 18, 19, 21, 22, 24, 27mm
		1/2"	x2	125, 250mm	
		1/2"	x1	ARTICULAÇÃO UNIVERSAL DE IMPACTO DE 1/2"	

52342 63,00€



KIT DE 11 CHAVES DE IMPACTO HEX. DE 1/2"



REPOSIÇÕES DISPONÍVEIS



		1/2"	x11	78mmL	10, 11, 12, 13, 14, 16, 17, 19, 21, 22, 24mm
--	--	------	-----	-------	--

53744 63,00€

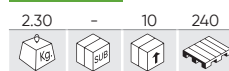

KIT DE 11 PCS. CABEÇA ALTA DE CHOQUE DE 12 LADOS 1/2"



REPOSIÇÕES DISPONÍVEIS



		1/2"	x11	78mmL	10, 11, 12, 13, 14, 16, 17, 19, 21, 22, 24mm
--	--	------	-----	-------	--

53060 34,90€

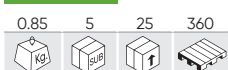

JOGO DE 12 CHAVES DE IMPACTO 1/2" HEX. PERFIL BAIXO



		1/2"	x12	10, 11, 12, 13, 14, 15, 16, 17, 18, 19, 20, 21mm
--	--	------	-----	--

52810 9,00€

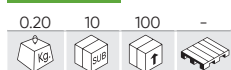

CHAVE DE IMPACTO XZN INVIOVÁVEL M16



- Soquetes de impacto de 75mm de comprimento quadrados de 1/2" para extrair o parafuso de drenagem com chave de impacto em transmissões de VAG, Porsche, Ford, etc.

		1/2"	x1	75mm	M16
--	--	------	----	------	-----

52811 9,90€



CHAVE DE IMPACTO XZN INVIOVÁVEL M18



- Para extrair o braço de direção do veículos do grupo VAG.

		1/2"	x1	75mm	M18
--	--	------	----	------	-----

52546

40,50€

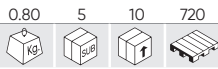

KIT DE 6 CHAVES E PUNTAS XZN DE IMPACTO DE 1/2"



REPOSIÇÕES DISPONÍVEIS

		1/2"	x3	43mmL	M14, M16, M18
		1/2"	x3	78mmL	M14, M16, M18

52344

197,00€

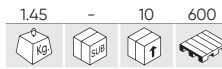

KIT DE 13 CHAVES DE IMPACTO DE 1/2" HEX E TORX



		1/2"	x5	45mmL	5, 6, 8, 10, 12mm
		1/2"	x8	45mmL	T30, T40, T45, T50, T55, T60, T70, T80

52339

61,00€

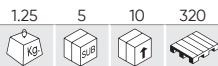

CONJUNTO DE 9 SOQUETES HEXAGONAIS DE IMPACTO 1/2"



REPOSIÇÕES DISPONÍVEIS

		1/2"	x9	78mmL	5, 6, 7, 8, 10, 12, 14, 17, 19mm
--	--	------	----	-------	----------------------------------

52340

58,00€

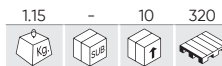

KIT DE 9 CHAVES DE IMPACTO TORX DE 1/2" T60



REPOSIÇÕES DISPONÍVEIS

		1/2"	x9	78mmL	T20, T25, T30, T40, T45, T50, T55, T60, T70
--	--	------	----	-------	---

51028

163,00€

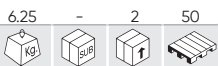

KIT DE 16 CHAVES DE IMPACTO



REPOSIÇÕES DISPONÍVEIS

		3/4"	x4	H17, H19, H22, H24	
		3/4"	x5	T60, T70, T80, T90, T100	
		3/4"	x4	E18, E20, E22, E24	
		1"	x1	22mm	
		3/4"	x1	22mm	
			x1	4mm	

52969

22,50€

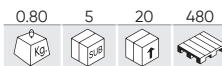

KIT DE 3 CHAVES DE IMPACTO HEX. LONGO



REPOSIÇÕES DISPONÍVEIS

		1/2"	x3	78mmL	17, 19, 21mm
--	--	------	----	-------	--------------

55016 169,00€

8.50 - 2 48 **NEW**

CONJUNTO DE 34 PEÇAS DE IMPACTO SEXTAVADAS 1/2"



REPOSIÇÕES DISPONÍVEIS

x12	38mm:	10, 11, 12, 13, 14, 15, 16, 17, 18, 19, 21, 22mm
x1	40mm:	24mm
x3	44mm:	27, 30, 32mm
x16	38mm:	10, 11, 12, 13, 14, 15, 16, 17, 18, 19, 21, 22, 24, 27, 30, 32mm
1/2"	x1	125mm
1/2"	x1	65mm

55005 198,00€

11.10 - 2 48 **NEW**

CONJUNTO DE 29 CHAVES DE CAIXA DE IMPACTO LONGAS SEXTAVADAS 1/2"



REPOSIÇÕES DISPONÍVEIS

1/2"	x29	78mm	8, 9, 10, 11, 12, 13, 14, 15, 16, 17, 18, 19, 20, 21, 22, 23, 24, 25, 26, 27, 28, 29, 30, 31, 32, 33, 34, 35, 36mm
------	-----	------	--

54896 39,50€

1.20 - 10 500 **NEW**

CONJUNTO DE 4 CHAVES DE IMPACTO DE DUPLA FACE



1/2"	x4	18.5-19.5, 20.5-21.5, 22-22.5, 27-27.5mm
1/2"	x1	78mm

54316 182,00€

5.85 - 2 252

CONJUNTO DE 8 CHAVES DE IMPACTO LONGAS 1"



REPOSIÇÕES DISPONÍVEIS

1"	x6	90mmL	24, 27, 30, 32, 33, 36mm
1"	x2	95mmL	38, 41mm

52348 179,00€

5.85 - 2 256

KIT DE 8 CHAVES DE IMPACTO DE 1"



REPOSIÇÕES DISPONÍVEIS

1"	x2	58mmL	24, 27mm
1"	x3	62mmL	30, 32, 33mm
1"	x2	65mmL	36, 38mm
1"	x1	68mmL	41mm

53470

176,00€

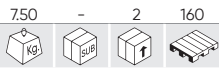

KIT DE 8 CHAVES DE IMPACTO LARGAS HEX. DE 3/4"



		3/4"	x8	90mmL	24, 27, 29, 30, 32, 34, 36, 38mm
--	--	------	----	-------	----------------------------------

52347

158,00€



KIT DE 8 CHAVES DE IMPACTO HEX. 3/4"



		3/4"	x8	90mmL	26, 27, 29, 30, 32, 35, 36, 38mm
--	--	------	----	-------	----------------------------------

53587

49,00€

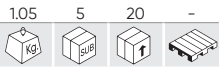

CONJUNTO DE 4 CHAVES DE CAIXA DE IMPACTO PARA RODAS DE LIGA LEVE - 1/2"



REPOSIÇÕES DISPONÍVEIS

		1/2"	x1		85mmL	15mm	Smart
		1/2"	x1		85mmL	17mm	Mercedes
		1/2"	x1		85mmL	21mm	Hyundai / Kia
		1/2"	x1		85mmL	22mm	Opel

52343

52,00€

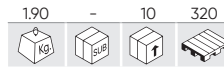

KIT DE 12 CHAVES DE IMPACTO DE 1/2" HEX. - ESPECIAL EXTRAÇÃO RODAS



		1/2"	x1		85mmL	17mm
		1/2"	x1		85mmL	19mm
		1/2"	x1		85mmL	21mm
		1/2"	x1		42mmL	27mm
		1/2"	x8		38mmL	10, 11, 13, 14, 17, 19, 22, 24mm

52338

29,00€

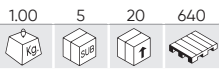

KIT DE 4 CHAVES IMPACTO DE 1/2" PARA RODAS



REPOSIÇÕES DISPONÍVEIS

		1/2"	x1		85mmL	17mm
		1/2"	x1		85mmL	19mm
		1/2"	x1		85mmL	21mm
		1/2"	x1		85mmL	22mm

54548

198,00€

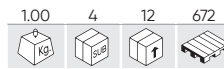

CONJUNTO DE 3 CHAVES DE IMPACTO DE BINÁRIO LIMITADO



REPOSIÇÕES DISPONÍVEIS

		1/2"	x1		101mmL	17mm
		1/2"	x1		101mmL	19mm
		1/2"	x1		101mmL	21mm

53988

101,00€

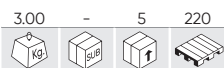

KIT DE 10 CHAVES DE IMPACTO DE 1/2"

	1/2"	x1		85mmL	15mm	
	1/2"	x1		85mmL	17mm	
	1/2"	x1		85mmL	19mm	
	1/2"	x1		85mmL	21mm	
	1/2"	x1		85mmL	22mm	
	1/2"	x1		85mmL	23mm	
	1/2"	x1		85mmL	24mm	
	1/2"	x1		85mmL	17mm	Mercedes
	1/2"	x1		85mmL	21mm	Hyundai/Kia
	1/2"	x1		85mmL	7/8"	Tesla



51336

19,90€

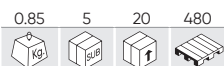

KIT DE 3 CHAVES DE IMPACTO DE 1/2"



REPOSIÇÕES DISPONÍVEIS

	1/2"	x1		85mmL	17mm
	1/2"	x1		85mmL	19mm
	1/2"	x1		85mmL	21mm

53197

29,00€



KIT DE 4 CHAVES DE IMPACTO PARA PARAFUSOS DE SEGURIDADE



		1/2"	x4	82mmL	17, 19, 21, 22mm
--	--	------	----	-------	------------------

53077

66,00€

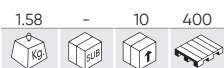

KIT DE BARRAS DE EXTENSÃO DE IMPACTO



REPOSIÇÕES DISPONÍVEIS

	1/2"	x1		100Nm
	1/2"	x1		110Nm
	1/2"	x1		200mm 120Nm
	1/2"	x1		135Nm
	1/2"	x1		150Nm

VOCÊ PODE GOSTAR...

REF.	"	Nm					€
13680	1/2"	200Nm		0.36	-	50	15,50€
13681	1/2"	190Nm		0.35	10	100 1800	15,50€
13682	1/2"	175Nm		0.32	-	50	15,50€
13683	1/2"	160Nm		0.30	10	100	15,50€
13689	1/2"	90Nm		0.20	5	50 1500	15,50€



54734

19,00€

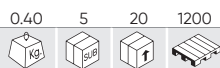

CONJUNTO DE 2 CHAVES DE IMPACTO 1/2" PARA RODAS DE ALUMÍNIO FORD



		1/2"	x1	18,5x19,5mm	FORD
		1/2"	x1	20,5x21,5mm	FORD

ARTICULAÇÃO UNIVERSAL DE IMPACT

REF.	"					€
11938	3/4"	0.62	10	50	-	47,00€
11990	1/2"	0.15	10	100	4000	15,30€



53043

57,00€

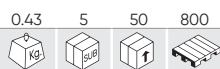

CONJUNTO DE 3 JUNTAS DE IMPACTO COM DUPLA POSIÇÃO (FIXA/ARTICULADA)



		x3	1/4", 3/8", 1/2"
--	--	----	------------------

53743

39,70€

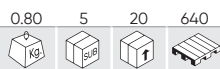

CONJUNTO DE 6 ADAPTADORES DE IMPACTO



REPOSIÇÕES DISPONÍVEIS

1/4"H - 3/8"M	1/2"H - 3/8"M
3/8"H - 1/4"M	1/2"H - 3/4"M
3/8"H - 1/2"M	3/4"H - 1/2"M

AUMENTO DE IMPACTO

REF.	"	mm					€
12937	1/2"	50mm	0.11	10	100	1500	9,50€
12074	1/2"	125mm	0.23	10	60	700	11,50€
12075	1/2"	250mm	0.45	10	100	350	15,50€
17134	1"	125mm	1.14	5	10	350	32,00€
17135	1"	250mm	1.97	2	10	270	39,00€
17136	1"	330mm	2.45	2	10	220	42,50€
17137	1"	400mm	2.98	1	5	160	59,00€



52545

179,00€

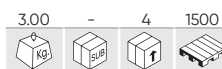

JOGO DE 2 ADAPTADORES DE IMPACTO



1"-1/2"H x 1"M



1"H x 1"-1/2"M

52544

94,00€

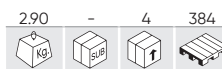

KIT DE 6 ADAPTADORES DE IMPACTO



REPOSIÇÕES DISPONÍVEIS

1/2"H - 3/4"M	3/4"H - 1"M
1/2"H - 1"M	1"H - 1/2"M
3/4"H - 1/2"M	1"H - 3/4"M



CHAVES DE IMPACTO - ESPECIAIS PARA PNEUS

REF.	"						€	
14172		15	85	SMART	0.20	10	50	10,00€
14173	1/2"	17	85	MERCEDES	0.20	10	100	10,00€
14178		21	85	KIA/HYUNDAI	0.25	10	50	10,00€
14177		22	85	OPEL	0.25	10	100	10,00€

REF.	"						€
11314	1/2"	17	85	0.22	10	100	10,00€
11315		19	85	0.25	10	100	10,00€
11316		21	85	0.26	10	100	10,00€
11628		22	85	0.27	10	100	10,00€

REF.	"						€
16748	1/2"	17	100	0.36	10	50	76,00€
16749		19	100	0.36	10	50	76,00€
16750		21	100	0.36	10	50	76,00€

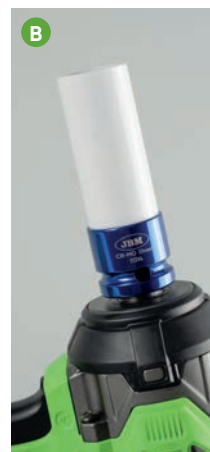

CHAVES DE CAIXA DE IMPACTO

1"

REF.						€
11153	36	65	0.70	5	20	23,40€
11154	37	65	0.73	6	24	24,00€
11155	38	65	0.90	6	12	24,40€
11156	39	65	0.74	6	24	26,60€
11157	40	70	0.78	6	12	27,50€
11158	41	70	0.95	6	18	28,50€
11159	42	70	1.00	6	18	30,30€
11160	43	70	0.95	6	12	31,20€
11161	44	70	0.90	6	18	32,30€
11162	45	70	1.10	4	8	33,10€
11163	46	70	1.00	5	20	34,00€
11164	47	70	1.05	4	8	34,90€
11165	48	70	1.00	4	8	35,70€
11166	50	75	1.21	5	20	36,20€
11167	51	75	1.18	4	8	38,00€
11168	52	85	1.18	-	10	39,20€
11169	53	85	1.27	4	12	40,00€
11170	54	85	1.33	4	12	41,00€
11171	55	85	1.44	2	8	43,00€
11172	56	85	1.47	4	8	47,00€
11173	57	85	1.44	4	8	47,50€

REF.						€
11174	58	85	1.58	4	8	48,00€
11175	59	85	1.58	4	120	49,00€
11176	60	90	1.75	2	4	53,00€
11177	62	90	1.63	2	4	55,00€
11178	63	90	1.75	-	8	56,00€
11179	65	90	1.87	2	10	59,00€
11180	67	90	1.93	2	8	65,00€
11181	68	90	1.93	2	8	67,00€
11182	70	95	2.05	2	4	70,00€
11183	71	95	3.10	-	6	73,00€
11184	73	95	3.27	-	4	87,00€
11185	75	95	3.34	-	6	91,00€
11186	76	95	3.35	-	5	97,00€
11187	78	95	3.47	-	5	98,00€
11188	80	95	3.60	-	4	103,00€
11189	85	100	3.80	-	4	121,00€
11190	89	100	3.80	1	2	138,00€
11191	90	100	3.90	-	4	149,00€
11192	92	105	4.85	-	2	152,00€
11193	95	105	4.90	-	2	183,00€
11194	100	105	4.43	-	4	190,00€

REF.						€
11621	105	155	8.50	1	2	290,00€
11622	110	155	8.13	1	2	399,00€
11623	115	155	8.62	1	2	489,00€

EXTRA LONGO

REF.						€
13745	28	90	0.77	6	24	25,20€
13746	30	90	0.95	6	12	25,40€
13747	32	90	0.92	6	12	25,40€
13748	33	90	0.88	2	16	26,00€



3/4"

REF.						€
11126	19	51	0.25	-	10	11,20€
11127	21	51	0.30	6	24	13,80€
11128	22	51	0.35	10	50	14,10€
11129	24	51	0.32	6	54	14,50€
11130	25	54	0.45	4	48	14,90€
11131	26	54	0.32	6	36	15,10€
11132	27	54	0.30	6	54	15,40€
11133	28	54	0.40	4	48	15,80€
11134	30	54	0.41	6	24	16,20€
11135	32	56	0.45	4	48	16,80€
11136	33	56	0.50	4	48	17,50€
11137	34	56	0.50	6	24	18,20€
11138	35	56	0.50	6	12	18,50€
11139	36	56	0.50	10	30	18,80€

REF.						€
11140	38	57	0.55	4	48	19,50€
11141	40	57	0.55	6	12	20,70€
11142	41	57	0.60	6	12	21,30€
11143	46	63	0.75	5	20	26,40€
11144	50	68	1.00	6	24	33,30€
11145	51	70	1.10	4	12	35,30€
11146	55	73	1.27	2	16	37,30€
11147	57	73	1.25	4	12	41,00€
11148	60	75	1.40	5	20	47,00€
11149	63	76	1.32	4	12	48,00€
11150	65	78	1.35	-	8	55,00€
11151	67	80	1.49	4	12	57,00€
11152	70	80	1.49	1	10	59,00€

LONGO

REF.						€
13723	19	90	0.43	2	12	18,50€
13724	21	90	0.50	5	20	18,70€
13725	22	90	0.61	6	18	19,00€
13726	24	90	0.56	10	30	19,20€
13727	26	90	0.51	6	18	19,50€
13728	27	90	0.50	5	20	20,00€
13729	29	90	0.70	6	12	21,00€
13730	30	90	0.70	2	24	21,60€
13731	32	90	0.71	2	24	22,00€
13732	33	90	0.75	6	24	23,80€
13733	34	90	0.85	6	18	24,90€
13734	35	90	0.80	6	18	25,70€
13735	36	90	0.81	5	20	25,80€
13736	38	90	0.83	6	18	25,90€

1/2"

LONGO

REF.	Canhão	Coroa	Caixa	Caixa	Caixa	€
12061	10	78	0.14	10	100	8,00€
14736	11	78	0.15	5	20	8,00€
12062	12	78	0.15	10	100	8,00€
12063	13	78	0.15	10	100	9,00€
14737	14	78	0.15	5	20	9,00€
12064	15	78	0.17	10	100	9,00€
12065	16	78	0.16	1	100	9,50€
12066	17	78	0.23	10	100	9,50€
12067	18	78	0.22	10	100	9,50€
12068	19	78	0.21	10	100	10,00€
12069	21	78	0.25	10	50	10,00€
12070	22	78	0.26	10	100	10,50€
12071	24	78	0.30	10	100	11,00€
12072	27	78	0.36	5	60	12,00€

CURTO

REF.	Canhão	Coroa	Caixa	Caixa	Caixa	€
14728	10	38	0.10	5	20	3,80€
14729	11	38	0.05	10	100	3,80€
14730	12	38	0.05	10	100	3,80€
14731	13	38	0.10	10	100	4,00€
14732	14	38	0.10	10	100	4,00€
11195	17	38	0.10	10	100	4,00€
11121	19	38	0.10	10	100	4,10€
14733	21	38	0.10	10	20	4,30€
14734	22	38	0.15	10	100	5,40€
11122	24	38	0.14	10	20	5,45€
11123	27	38	0.20	10	50	6,50€
11124	30	38	0.20	10	50	7,65€
11125	32	38	0.23	10	50	8,50€

1/2"

CURTO

REF.	Canhão	Coroa	Caixa	Caixa	Caixa	€
16569	36	42	0.47	10	40	21,00€
16570	27	42	0.35	10	40	21,00€

LONGO

REF.	Canhão	Coroa	Caixa	Caixa	Caixa	€
14738	10	78	0.15	10	100	5,50€
14739	11	78	0.15	10	100	5,50€
14740	12	78	0.16	10	100	5,55€
14741	13	78	0.15	10	100	5,55€
14742	14	78	0.15	10	100	5,55€
14743	16	78	0.14	10	100	5,60€

REF.	Canhão	Coroa	Caixa	Caixa	Caixa	€
14744	17	78	0.18	10	50	5,80€
14745	19	78	0.22	10	50	6,25€
14746	21	78	0.24	10	100	6,40€
14747	22	78	0.27	10	50	7,10€
14748	24	78	0.30	10	100	8,30€
11613	27	78	0.35	10	20	11,00€
11614	30	78	0.40	10	100	13,00€
11615	32	78	0.45	4	48	14,20€
11616	33	78	0.44	6	12	18,10€
11617	34	78	0.42	6	24	18,70€
11618	35	78	0.48	10	100	18,80€
11619	36	78	0.47	4	48	19,50€

52834

195,00€

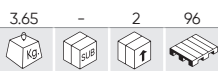

CAIXA COM CHAVES COM DENTES EXTERIORES



x11 22x3.3, 26x3.8, 30x4.3, 33x4.0, 37x4.8, 44x5.3, 50x5.8, 56x5.8, 63x6.3, 69x6.8, 75x6.8mm

1"

LONGO

REF.	Canhão	Coroa	Caixa	Caixa	Caixa	€
11624	65	105	2.40	-	2	189,00€
11625	85	105	5.35	-	2	282,00€
12984	105	105	5.00	-	2	379,00€



1/2"

LONGO

REF.	Canhão	Coroa	Caixa	Caixa	Caixa	€
16718	x1	M12	72	0.70	12 72	9,00€
16719	x1	M12	115	0.70	12 72	9,50€
16720	x2	M12	72, 115	1.40	12 72	17,20€



52835

272,00€



KIT CHAVES COM DENTES INTERIORES



x10 26.0x22.0x2.8x2.5, 31.0x23.5x2.8x3.0, 34.0x26.5x3.8x2.5, 38.0x29.5x4.8x2.5, 42.0x34.5x3.8x3.5, 50.0x40.5x4.8x3.5, 58.0x46.5x4.8x4.0, 75.0x59.5x5.8x4.5, 82.0x65.8x5.8x5.0, 88.0x71.8x5.6x5.0mm

52914 223,00€

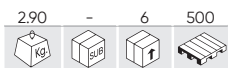

CHAVE DE EXTRAÇÃO DE CASTILHO BPW 120MM DR.41MM



120mm
8 CANTOS
CUADRADO HEXAGONAL 41mm

52915 199,00€



CHAVE DE EXTRAÇÃO DE CASTILHO BPW 111MM DR.41MM



111mm
OVAL
CUADRADO HEXAGONAL 41mm

52916 218,00€



CHAVE DE EXTRAÇÃO DE CASTILHO BPW 109MM DR.41MM



109mm
8 CANTOS
CUADRADO HEXAGONAL 41mm

52917 122,00€

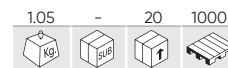

CHAVE DE EXTRAÇÃO DE CASTILHO BPW 65MM



65mm
OVAL
DIAGONAL 36MM

52918 146,00€



CHAVE HUBCAPS EIXO TRASEIRO BPW 95MM



95mm
CUADRADO 3/4"

52919 181,00€



CHAVE NUT RODA BPW 110MM 3/4"



110mm
8 CANTOS
CUADRADO 3/4"

52920 155,00€



CHAVE EXTRAÇÃO ROLAMENTIOS EIXO BPW 80MM 3/4"



80mm
CUADRADO 3/4"

52921 117,00€



CHAVE EXTRAÇÃO NUT EIXO TRASEIRO BPW 65MM 3/4"



65mm
CUADRADO 3/4"

52922 180,00€



CHAVE EXTRAÇÃO PORCA ROLAMENTOS EIXOS BPW 85MM 3/4"



85mm
6 CANTOS
CUADRADO 3/4"

52923 59,00€



CHAVE EXTRAÇÃO NUT SUSPENSÃO SCANIA 28X37MM 3/4"



28x37mm
CUADRADO 3/4"

52924 52,00€



CHAVE EXTRAÇÃO EIXO SUSPENSÃO SCANIA 34X46MM 3/4"



34x46mm
CUADRADO 3/4"

52925 176,00€



CHAVE RODA DIANTEIRA SCANIA 80MM H41



80mm
8 CANTOS
CUADRADO HEXAGONAL 41mm

52926 201,00€



CHAVE EXTRAÇÃO RODA NUT SCANIA 100MM 3/4" 8 CANTOS



100mm
8 CANTOS
CUADRADO 3/4"

52927 59,00€



CHAVE AMORTECEDOR TRASEIRO SCANIA 34X56MM 3/4"



34x56mm
CUADRADO 3/4"

52928 172,00€



CHAVE RODA DIANTEIRA SCANIA 80MM 3/4" 8 CANTOS



80mm
8 CANTOS
CUADRADO 3/4"

52929 185,00€



CHAVE DE PORCA DE RODA SCANIA 95MM 3/4" 8 CANTOS



95mm
8 CANTOS
CUADRADO 3/4"

FERRAMENTAS DE IMPACTO

52930 117,00€

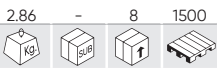

INSTALADOR PARA VIRABREQUIM TRASEIRO RETENTOR ÓLEO SCANIA



SCANIA 310/320
RETENTOR 0366303-R

52931 45,00€

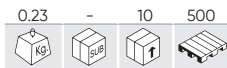

CHAVE CAMINHÃO SCANIA ROTAÇÃO EIXO DE COMANDO 1/2"



CUADRADO 1/2"

52932 45,00€

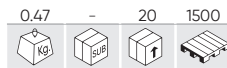

CHAVE PARA VÁLVULA DE INJEÇÃO ELECTROMAGNÉTICA SCANIA 38MM 1/2"



Ø38mm
CUADRADO 1/2"

52933 194,00€

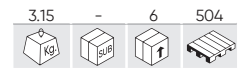

CHAVE 8 ALMENAS SCANIA 420



Ø116mm - Ø100mm
8 ALMENAS
CUADRADO 3/4"
SCANIA 420

53430 286,00€



CHAVE DE BUCHA PARA IVECO



Ø134mm - Ø110,5mm
118x134mm
IVECO
12 FACES

52935 94,00€



CHAVE DE PORCA DE CAMINHÃO BENZ/MAN 60MM



60mm
CUADRADO 3/4"

52936 199,00€



CHAVE EIXO TRASEIRO CAMINHÃO BENZ/MAN 80-95MM



80-95mm
CUADRADO 3/4"
6 ALMENAS

52937 265,00€



CHAVE EXTRAÇÃO HUB TRASEIRO CAMIÓN BENZ / MAN 95-115MM



95-115mm
CUADRADO 3/4"
6 ALMENAS

52938 199,00€



CHAVE EXTRAÇÃO EIXO DIREÇÃO BENZ / MAN



100mm
CUADRADO 3/4"
6 ALMENAS

52939 28,00€



CHAVE PARA EXTRAÇÃO DE VÁLVULA DE INJEÇÃO DIESEL BENZ/MAN



22-28mm
CUADRADO 1/2"
4 ALMENAS

52940 235,00€



CHAVE PARA NUT DIFERENCIAL TRASEIRO BENZ/MAN



101mm
CUADRADO 3/4"
6 ALMENAS

52941 70,00€



CHAVE ROTAÇÃO VOLANTE DO MOTOR BENZ E MAN 2 ENGRENAGENS



CUADRADO 1/2"

52942 105,00€



CHAVE ROTAÇÃO VOLANTE BENZ Y MAN 3 ENGRENAGENS



CUADRADO 1/2"

52943 75,00€



CHAVE ROTAÇÃO VOLANTE DE MOTOR MAN



CUADRADO 1/2"

52934 102,00€



CHAVE PORCA HUB PARAFUSOS CAMINHÃO BENZ/MAN 56MM



56mm
CUADRADO 3/4"

REF.	mm	Kg	SUB	€
52944	30	1.00	20	110,00€
52945	32	2.74	24	281,00€

EXTRACTOR DE CABEÇA DE CAMINHÃO



52944
CUADRADO HEXAGONAL
30mm



52945
CUADRADO HEXAGONAL
32mm

CARROÇARIA

212 FERRAMENTAS PARA CARROÇARIA

217 RESTAURAÇÃO DE FARÓIS

218 SUBSTITUIÇÃO DE VIDRO

220 REPARAÇÃO DO CHASSIS

222 MOBÍLIA AUXILIAR

226 DETAILING

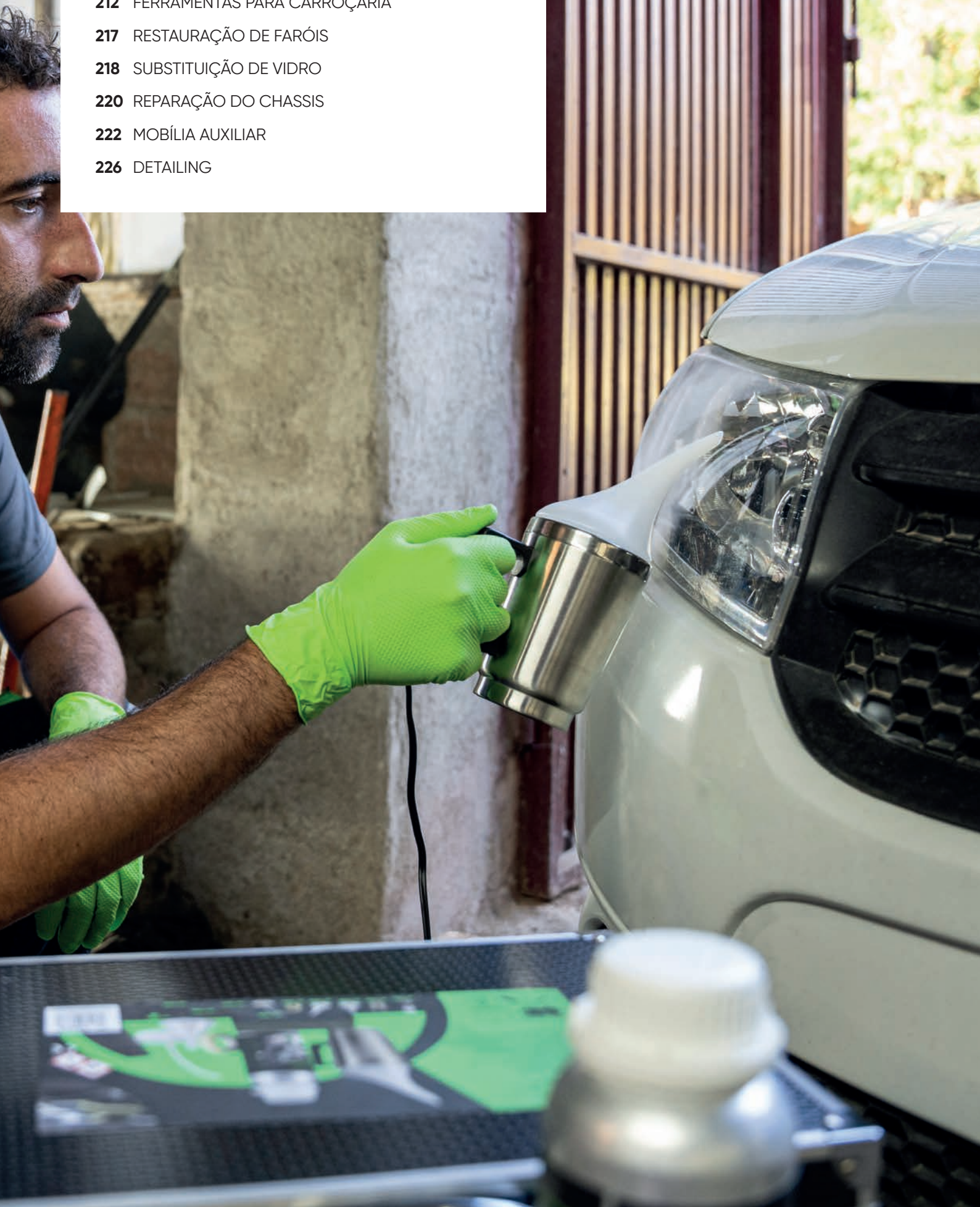

53224

142,00€

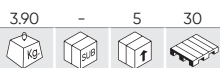

KIT REPARADOR DE AMOLGADELAS



REPOSIÇÕES DISPONÍVEIS



- x5 SACO DE 5 DISCOS AZUIS PARA REF. 53224
- x5 SACO DE 4 DISCOS AMARELOS PARA REF. 53224
- x10 SACO DE 10 DISCOS VERMELHOS PARA REF. 53224
- x5 SACO DE 5 BARRAS DE COLA PARA REF. 53224

52876

182,00€



KIT ENCONTRADORES PARA CHAPEIROS 7 PCS



REPOSIÇÕES DISPONÍVEIS



- x1 ENCONTRADOR TIPO BIGORNA
- x1 ENCONTRADOR TIPO TRILHO
- x1 ENCONTRADOR TIPO DUPLA FACE
- x1 ENCONTRADOR TIPO PUNHO COM CABEÇA CONVEXA
- x1 ENCONTRADOR TIPO VIRGULA
- x1 ENCONTRADOR TIPO CALCANHAR
- x1 ENCONTRADOR TIPO VIRGULA CON MANGO

51131

61,00€

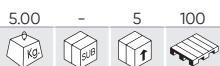

KIT ENCONTRADORES E MARTELOS PARA CHAPEIROS



REPOSIÇÕES DISPONÍVEIS



- x1 MARTELO BOCA PLANA
- x1 MARTELO BOCA PLANA/PEÑA
- x1 MARTELO BOCA PLANA CÔNICA
- x1 ENCONTRADOR TIPO CALCANHAR
- x1 ENCONTRADOR TIPO CARRIL
- x1 ENCONTRADOR DUPLA EXTREMIDADE
- x1 ENCONTRADOR TIPO VIRGULA

53545

38,50€

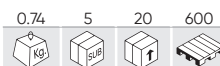

CAIXA DE 5 CHAVES DE CABEÇAS HEXAGONAIS ALONGADAS 3/8"



- x1 8mm
- x1 10mm
- x1 3/8" 120mmL 12mm
- x1 13mm
- x1 14mm



55116

125,50€



NEW

CONJUNTO DE REPARAÇÃO DE AMOLGADELAS DE CARROÇARIA 11 PEÇAS

Peças	11
Peso	10,50Kg
Dimensões (CxLxA)	770x100x215mm



51832 18,00€

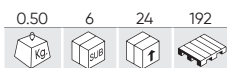

JOGO DE 4 ALAVANCAS DE NYLON TIPO FACAS



x4	19x273mm
	22x273mm
	26x273mm
	36x273mm

50903 30,80€

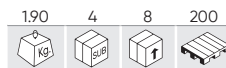

JOGO DE 5 ALAVANCAS DE FERRO



x5	180mm
	280mm
	380mm
	430mm
	600mm

52026 34,50€

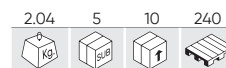

JOGO DE 2 ALAVANCAS DE FERRO



x2	900mm
	900mm

52851 9,65€



JOGO DE 2 ALAVANCAS PARA EXTRAÇÃO DE GRAMPOS



x2	7x220mm
	8.5x245mm

53110 29,50€



KIT DE 6 ALAVANCAS



x1	4.5x240mm	x1	4.5x490mm
	8.5x240mm		8.5x490mm
	10.3x24mm		10.3x490mm

51360 8,20€



51361 12,00€



PÉ DE CABRA



x1	51360	x1	18" x 5/8
	51361		24" x 3/4

50901 16,00€

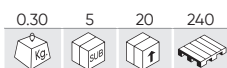

JOGO DE 5 ALAVANCAS DE NYLON



x5	60x160, 63x175, 30x200, 20x180, 20x215mm
----	--

52788 39,00€

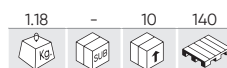

KIT DE 27 ALAVANCAS DE NYLON



52977

141,00€

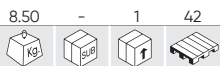

KIT DE 4 ALAVANCAS EXTRALARGAS

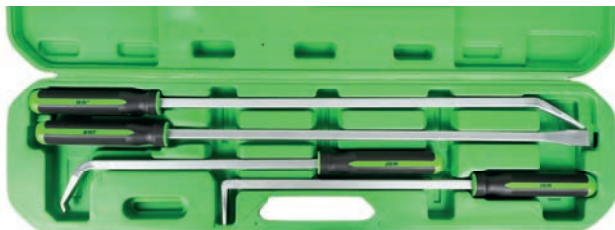

Peças	4
Medidas	0° 900x16mm, 30°900x16mm, 75°600x16mm, 90°600x16mm
Peso	8,50Kg
Dimensões (CxLxA)	1005x260x80mm

52540

221,00€



VENTOSA PNEUMÁTICA COM MARTELO DESLIZANTE



Peças	5
Resistência	7,6BAR
Diâmetro	75, 100, 125mm
Comprimento	620mm
Peso	4,36Kg
Dimensões (CxLxA)	620x250x100mm

54017

12,00€

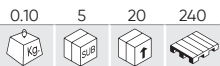

FERRAMENTA DE VEDAÇÃO DE SILICONE

Contém	Almohadillas de silicona/Silicone pads
Peso	0,10Kg
Dimensões (CxLxA)	270x44x95mm

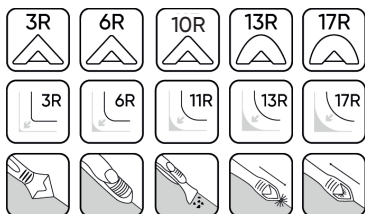

52533

10,00€

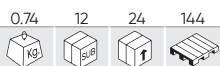

PISTOLA SILICONE 300ML



Capacidade	300ml
Peso	0,74Kg
Dimensões (CxLxA)	360x215x60mm

53567

43,00€



PISTOLA DE SILICONE PNEUMÁTICA 310ML



REPOSIÇÕES DISPONÍVEIS

Entrada de ar	1/4"
Pressão do trabalho	2,5-5BAR
Capacidade	310ml
Peso	1,05Kg
Dimensões (CxLxA)	305x185x65mm

60032

123,00€

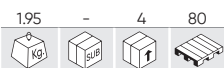

PISTOLA PARA SILICONE A BATERIA

Tensão	20V
Força máxima de empurrão	2500N
Velocidade de avanço	0,5-8 mm/s (30-480mm/min)
Capacidade do cartucho	300ml
Velocidade	Ajustable/Adjustable
LED	Si/Yes
Compatível com	60012, 60013, 60015, 60016, 60017
Peso	1,60Kg
Dimensões (CxLxA)	420x70x270mm



REPOSIÇÕES DISPONÍVEIS

60032C

266,00€



PISTOLA PARA SILICONE A BATERIA COM CAIXA

Tensão	20V
Força máxima de empurrão	2500N
Velocidade de avanço	0,5-8mm/s (30-480mm/min)
Capacidade do cartucho	300ml
Velocidade	Ajustable/Adjustable
Inclui	60032, 60013, 60016
LED	Si/Yes
Compatível com	60012, 60013, 60015, 60016, 60017
Peso	4,96Kg
Dimensões (CxLxA)	500x130x400mm



REPOSIÇÕES DISPONÍVEIS



PÁGINA 153

PILHAS E CARREGADORES NÃO INCLUÍDOS NAS FERRAMENTAS INDIVIDUALES

Três tipos de bateria e dois tipos de carregador. Escolha o que você preferir!



53525

12,00€

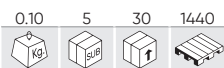

GRAMPO PARA ABRIDORES DO CAPÔ E PORTA-MALAS



Diâmetro	10mm
Peso	0,10Kg
Dimensões (CxLxA)	140x90x30mm

53655

12,00€

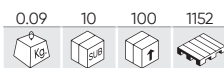

CHAVE PARA MAÇANETAS VAG



Marcas	VAG
Peso	0,09Kg
Dimensões (CxLxA)	340x70x40mm

54246

104,00€

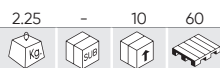

BALANÇA DE PRECISÃO DE 5KG



Capacidade	5Kg
Precisão	0,1g
Medição de voltagem em corrente alternada (AC)	220V
Medição de voltagem em corrente contínua (DC)	6V
Temperatura de trabalho	0-40°C
Umidade relativa	10%<RH<85%
Peso	2,25Kg
Dimensões (CxLxA)	280x115x285mm

54247

99,00€



BALANÇA DE PRECISÃO DE 2KG



Capacidade	2Kg
Precisão	0,1g
Medição de voltagem em corrente alternada (AC)	220V
Medição de voltagem em corrente contínua (DC)	6V
Temperatura de trabalho	0-40°C
Umidade relativa	10%<RH<85%
Peso	2,25Kg
Dimensões (CxLxA)	352x136x240mm

53230

20,50€



JOGO DE UTENSÍLIOS PARA ABRIR CARROS

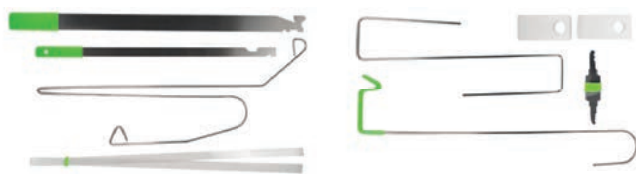

x2	Fita de abertura de puxadores
x2	Cunha de nylon com furo central
x1	Gancho rígido em forma de "s"
x1	Gancho deslizante para desbloqueio de seguros
x1	Alavanca de desbloqueio larga 610mm
x1	Alavanca de bloqueio estreito 558mm
x1	Chave de encaixe para fechaduras
x1	Gancho especial

52077

29,50€



JOGO DE 4 ALMOFADAS INFLÁVEIS



x1	Almofada de 16x16cm
x1	Almofada de 32x12cm
x1	Almofada de 19x6cm
x1	Almofada de 18x4,5cm
x1	Bomba manual

53486

30,50€

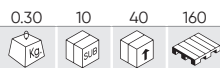

ECRÃ PARA INSPEÇÃO DE AMOLGADELAS



Diâmetro	800mm
Peso	0,30Kg
Dimensões (CxLxA)	320x300x40mm

15375

28,00€

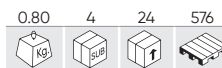

GARRAFA COM LÍQUIDO PARA REF. 53673



Capacidade	600ml
Peso	0,80Kg
Dimensões (CxLxA)	75x75x190mm

53673

80,00€

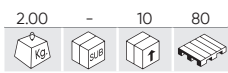

KIT DE RESTAURAÇÃO DE FARÓIS

x6	KIT DE 6 PAPÉIS ABRASIVOS PARA REF. 53673
x1	ADAPTADOR AC-DC PARA REF. 53673
x1	ADAPTADOR 12V PARA REF. 53673
x1	COPO DE EVAPORAÇÃO PARA REF. 53673
x1	TAMPA CURVADA COM ANEL DE VEDAÇÃO DE BORRACHA PARA REF. 53673
x1	TAMPA PLANA COM ANEL DE VEDAÇÃO DE BORRACHA PARA REF. 53673
x1	FUNIL PARA REF. 53673
x1	PLACA DE MOAGEM PARA REF. 53673
x1	PAPEL TEXTURIZADO PARA REF. 53673
x1	GARRAFA COM LÍQUIDO PARA REF. 53673



CONJUNTO DE 10 ELEMENTOS DO PAPEL ABRASIVO

REF.	GRÃO				€
14710	180	0.25	10	100	3,90€
14711	280	0.20	10	100	4,00€
14712	360	0.20	10	100	4,00€

REF.	GRÃO				€
14713	600	0.15	10	100	4,25€
14714	800	0.15	10	100	4,50€
14715	1200	0.10	10	100	4,75€



VIDEO TUTORIAL



REPOSIÇÕES DISPONÍVEIS

52740

690,00€

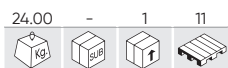

ALINHADOR DE FARÓIS COM LUXÓMETRO 152CM



Altura mínima de elevação	230mm
Altura máxima de elevação	1350mm
Medição	LUX Digital
Compatível com	Hálogeno/Xenón
Peso	24,00Kg
Dimensões (CxLxA)	520x280x1520mm

52836

1.100,00€

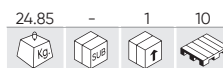

ALINHADOR DE FARÓIS COM DUPLO LASER E LUXÓMETRO



VIDEO TUTORIAL



Altura mínima de elevação	230mm
Altura máxima de elevação	1350mm
Medição	Láser/Laser, LUX Digital
Compatível com	Cualquier tipo de faro/Any type of car lighthouse
Peso	24,85Kg
Dimensões (CxLxA)	520x270x1560mm

53626

18,00€

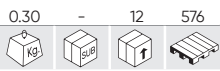

KIT DE RESTAURAÇÃO DE FARÓIS

- x2 EP800 Discos de lixar
- x2 P1200 Discos de lixar
- x2 P2000 Discos de lixar
- x2 3.0ml Líquido protetor UV
- 🔧 x2 Adaptador (3/8" & 1/4")
- 🧴 x1 85gm Pasta de polimento
- 📄 x1 Fita adesiva
- x1 Disco de polimento de lã
- 🧽 x1 Disco de Esponja Branco



EM EXPOSITOR DE 12 UDS

53729

20,50€

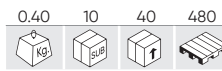

KIT DE FERRAMENTAS PARA AJUSTAR FARÓIS

- 🔧 x1 H6
- 🔧 x1 300mm H7
- 🔧 x1 T25



VENTOSA

52262

7,50€

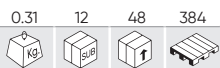

Peças	1
Diâmetro	115mm
Capacidade	40,00Kg

52263

13,50€



Peças	1
Diâmetro	115mm
Capacidade	70,00Kg

52264

21,50€

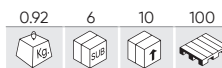

Peças	1
Diâmetro	115mm
Capacidade	100,00Kg

52265

30,50€

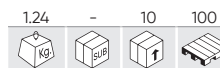

Peças	1
Diâmetro	115mm
Capacidade	120,00Kg

52295

7,00€

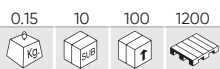

Peças	2
Diâmetro	60mm
Capacidade	5,00Kg

52589

13,00€

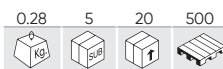

Peças	1
Diâmetro	70mm
Capacidade	8,00Kg

52765

21,70€

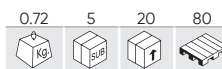

Peças	1
Diâmetro	120mm
Capacidade	80,00Kg

52998

48,00€

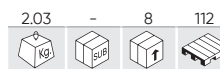

Peças	3
Diâmetro	120mm
Capacidade	80,00Kg

53232

39,50€

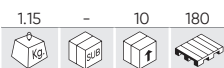

FERRAMENTAS PARA SUBSTITUIÇÃO DE PARA-BRISAS

- x1 ÚTIL EXTRATOR DE MOLDURAS
- x1 ALAVANCA PARA EXTRAIR A BORRACHA
- x1 GANCHO EXTRATOR
- x1 1,8M DE FIO DE CORTE
- x2 CABOS PARA O FIO DE CORTE
- x1 PASSA-CABOS



TAMBÉM PODE TE INTERESSAR...

REF.	DESCRIÇÃO					€
13813	CABO PARA EXTRAÇÃO DE PÁRA-BRISAS	0.10	10	60	1200	7,00€
13814	FERRAMENTA PARA EXTRAÇÃO DE PÁRA-BRISAS	0.20	10	60	1080	11,00€



55012

680,00€

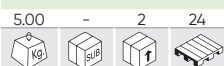

NEW

CONJUNTO DE FERRAMENTAS PARA SUBSTITUIÇÃO DE PARA-BRISAS COM MALETA

- x1 ÂNCORA DA LINHA DE CORTE
- x1 POLIA DA LINHA DE CORTE
- x1 ENROLADOR DA LINHA DE CORTE
- x1 CABO DE FIBRA SINTÉTICA L:100M
- x1 FERRAMENTA PERFURADORA
- x1 BARRA PARA INSTALAÇÃO DO CINZEL
- x1 FERRAMENTA DE GANCHO TIPO PICO 90°
- x1 CHAVE DE CATRACA COM SOQUETE 1/4"
- x1 TÁBUA PROTETORA

REPOSIÇÕES
DISPONÍVEIS

52321

8,80€

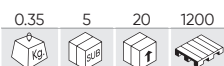
CINTA DE APERTO
POLIÉSTER COM TENSOR
5M X 25MM

Peças	2
Comprimento	5m
Capacidade	800Kg
Peso	0,35Kg
Dimensões (CxLxA)	125x115x30mm

52327

12,00€

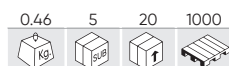
CINTA DE APERTO
POLIÉSTER COM TENSOR
8M X 25MM

Peças	2
Comprimento	8m
Capacidade	800Kg
Peso	0,46Kg
Dimensões (CxLxA)	150x140x40mm

50577

12,60€

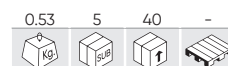

ALICATE DE PRESSÃO



Comprimento	280mm
Peso	0,53Kg

52385

268,00€



JOGO DE 6 ALICATES DE MORDAÇA



52982

55,00€

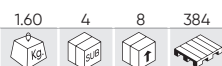

JOGO 3 MORDAÇAS DE PRESSÃO EXTRA-LARGAS



Ângulo	90°
Comprimento	340mm



Ângulo	45°
Comprimento	360mm



Ângulo	0°
Comprimento	370mm

53675

53,00€

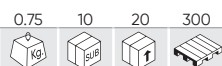

ALICATE DE PONTAS DIRETAS



EM EXPOSITOR DE 10 UDS



Material	Acero/Steel
Abertura	Ajustable/Adjustable
Comprimento	10"-254mm
Peso	0,75Kg

53676

47,00€

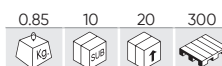

ALICATE DE PONTAS CURVAS



EM EXPOSITOR DE 10 UDS



Material	Acero/Steel
Abertura	Ajustable/Adjustable
Comprimento	10"-254mm
Peso	0,85Kg

53677

59,00€

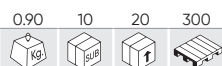

ALICATE DE PONTAS CURVAS E ALMOFADA GIRATÓRIA



EM EXPOSITOR DE 10 UDS



Material	Acero/Steel
Abertura	Ajustable/Adjustable
Comprimento	10"-254mm
Peso	0,90Kg

53678

55,00€



ALICATE DE PONTAS CURVAS LONGAS







EM EXPOSITOR DE 10 UDS



Material	Acero/Steel
Abertura	Ajustable / Adjustable
Comprimento	10½"-270mm
Peso	0,90Kg

MORDAÇAS

REF.	DESCRIÇÃO	mm	MATERIAL		T					€
52390	MORDAÇA ESPECIAL SOLDADURA	250mm	CrMo	-	-	0.50	5	40	640	37,50€
52474	MORDAÇA DE ARGOLA 5T	190mm	Aço	0-20mm	5T	3.49	-	5	1500	69,00€
52475	MORDAÇA PLANO 3T	170mm	Aço	0-25mm	3T	3.60	-	10	1500	62,00€
52476	MORDAÇA QUADRADO 5T	220mm	Aço	0-25mm	5T	3.10	-	10	1500	50,00€
52477	MORDAÇA DE MOLA 2T	200mm	Aço	0-60mm	2T	2.65	-	10	1500	76,50€
52478	MORDAÇA 90° 5T	170mm	Aço	0-20mm	5T	2.90	-	10	1500	49,00€
52479	MINI MORDAÇA PLANO 90° 3T	155mm	Aço	0-20mm	3T	1.18	-	30	1500	24,70€
52480	MINI MORDAÇA QUADRADA 90° 3T	210mm	Aço	0-25mm	3T	2.00	-	10	1500	44,00€
52481	MORDAÇA QUADRADA 3T	220mm	Aço	0-20mm	3T	2.05	-	10	1500	52,00€
52482	MORDAÇA PLANO ÂNGULO 45° 5T	210mm	Aço	0-10mm	5T	2.13	-	12	1500	44,00€
52483	MORDAÇA PLANO MINI 5T	210mm	Aço	0-10mm	5T	2.02	-	12	1500	41,00€
52484	UNIÃO DE CORRENTES 3T	280mm	Aço	0-110mm	3T	1.19	-	11	1500	70,00€
52485	UNIÃO DE GANCHOS DE 4T	270mm	Aço	0-90mm	4T	1.17	-	30	1000	54,00€
52486	UNIÃO DE CORRENTES GANCHOS 3T	280mm	Aço	0-110mm	3T	1.21	-	11	1500	66,00€
52487	MORDAÇA DE MOLA 5T	220mm	Aço	0-20mm	5T	2.27	-	7	1000	63,00€
52502	MORDAÇA DE PRESSÃO PARA SOLDADURA	280mm	CrMo	0-110mm	-	0.84	10	30	540	33,50€
52503	MORDAÇA DE PRESSÃO PESCOÇO DE CISNE MAXILAR OSCILANTES	280mm	CrMo	0-105mm	-	0.85	-	30	540	35,00€
52504	MORDAÇA DE DUPLA GARRA PARA BATE-CHAPA	225mm	CrMo	0-50mm	-	1.14	-	30	480	27,60€
52505	MORDAÇA PESCOÇO DE CISNE	170mm	CrMo	0-40mm	-	0.27	36	72	2160	22,50€
52506	MORDAÇA PESCOÇO DE CISNE, MAXILAS OSCILANTES	170mm	CrMo	0-50mm	-	0.28	36	72	2160	16,00€
52507	MORDAÇA DE PRESSÃO PARÁGRAFO LATOEIROS	250mm	CrMo	0-80mm	-	0.77	5	30	420	32,50€
52511	MORDAÇA PARA SOLDADURA 18"	440mm	CrMo	0-225mm	-	1.31	-	20	280	44,50€
52512	MORDAÇA DE PRESSÃO SOLDADURA, MAXILAS OSCILANTES	450mm	CrMo	0-155mm	-	1.31	-	20	280	53,00€



52390



52474



52475



52476



52477



52478



52479



52480



52481



52482



52483



52484



52485



52486



52487



52502



52503



52504



52505



52506



52507



52511



52512

53983

215,00€

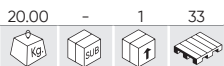

SUPORE DE PEÇAS - PÁRA-BRISAS E COBERTURA



Capacidade	150Kg
Dimensões dobradas	1200x120x210mm
Peso	19,40Kg
Dimensões (CxLxA)	1200x700x635mm

53124

287,00€



CAVALETE UNIVERSAL TELESCÓPICO



Capacidade	100Kg
Dimensões dobradas	25x860x840mm
Peso	21,10Kg
Dimensões (CxLxA)	1380x860x1300mm

53125

477,00€

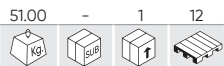

CARRO PARA ARMAZENAGEM DE PEÇAS

Capacidade	150Kg
Peso	51,00Kg
Dimensões (CxLxA)	900x610x1980mm



50923

454,00€

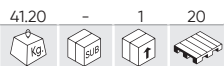

CARRO TRANSPORTADOR ESP. CHAPEIROS 340KG



REPOSIÇÕES DISPONÍVEIS

Capacidade	340Kg
Abertura	0-1100mm
Peso	41,20Kg
Dimensões (CxLxA)	1340x250x240mm

50839

198,00€



PORTA CARROS HIDRÁULICO 680KG



Capacidade	680Kg
Abertura	345-660mm
Peso	19,20Kg
Dimensões (CxLxA)	680x625x230mm

53079

89,00€

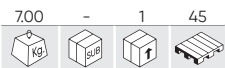

CAVALETE EN "X"



Capacidade	100Kg
Dimensões dobradas	660x1140x300mm
Peso	6,77Kg
Dimensões (CxLxA)	600x680x870mm

53080

99,00€

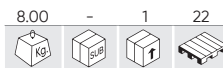

CAVALETE PARA PARA-BRISA



Capacidade	70Kg
Dimensões dobradas	1130x285x990mm
Peso	7,87Kg
Dimensões (CxLxA)	1130x610x990mm

52749

79,00€

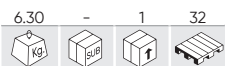

CAVALETE PROFESSIONAL

REPOSIÇÕES
DISPONÍVEIS

Capacidade	220Kg
Dimensões dobradas	1030x905x500mm
Peso	6,25Kg
Dimensões (CxLxA)	1030x390x1000mm

53736

99,00€



CAVALETE SUPORTE PARA-CHOQUES



Capacidade	25Kg
Dimensões dobradas	600x310x1230mm
Peso	8,10Kg
Dimensões (CxLxA)	600x750x1060mm

53685

310,00€

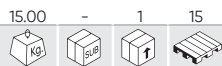

SUPORE PARA PARACHOQUE



Capacidade	25Kg
Dimensões dobradas	960x865x95mm
Peso	14,50Kg
Dimensões (CxLxA)	762x1118x1346mm

54579

229,00€

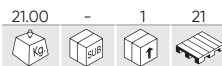

SUPORE MÓVEL PARA ARMAZENAMENTO DE PARA-CHOQUES



Capacidade	60Kg
Capacidade da barra	15Kg
Peso	21,00Kg
Dimensões (CxLxA)	1200x1200x2150mm

53134

145,00€

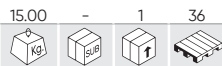

SUPORE PARA PINTURA AJUSTÁVEL

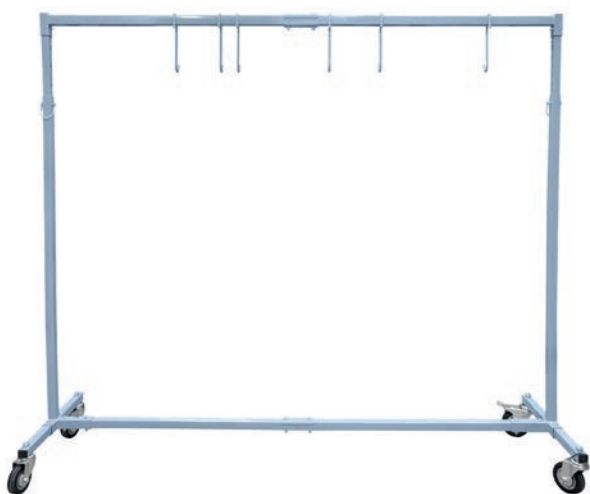

Capacidade	150Kg
Altura mínima de elevação	1270mm
Altura máxima	2030mm
Contém	6 Ganchos/Hooks
Peso	14,70Kg
Dimensões (CxLxA)	1770x500x2030mm

53126

243,00€

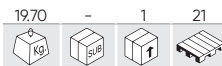

SUPORE BASCULANTE PARA PINTURA



Capacidade	50Kg
Contém	6 Braços de sujeição/Support arms
Peso	19,70Kg
Dimensões (CxLxA)	1220x250x165mm

54959 **268,00€**

20.20 - 1 16 **NEW**

SUPORE MÓVEL PARA PINTURA DE RODAS



Material	GS
Altura	1100 - 1420mm
Rotativo	360°
Bandejas	2
Diâmetro da roda	15" - 22"
Dimensões (CxLxA)	900x670x1100mm

54960 **159,50€**

11.10 - 1 33 **NEW**

SUPORE UNIVERSAL PARA PAINÉIS E PARA-CHOQUES



Material	GS
Rotativo	90°
Carga máxima	100Kg
Dimensões (CxLxA)	1220x1330x1870mm
Peso	10,50Kg

54961 **20,00€**

1.10 1 20 240 **NEW**

SUPORE PARA RODAS

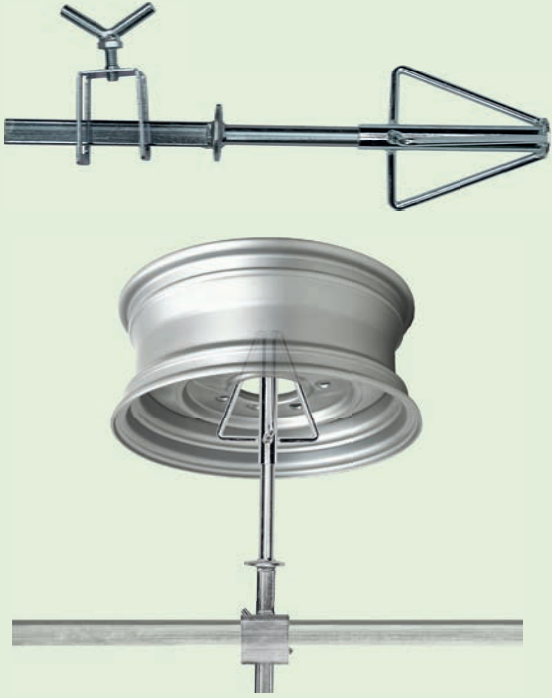

Peso	1,15Kg
Dimensões (CxLxA)	130x100x380mm

54962 **430,50€**

40.25 - 1 14 **NEW**

CARRINHO PARA PEÇAS COM SUPORTE PARA PAINÉIS



Carga máxima	120Kg
Capacidade da barra	40Kg
Peso	40,00Kg
Dimensões (CxLxA)	1220x1330x1900mm



52230

398,00€

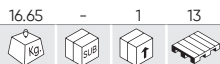

PLATAFORMA DE ALUMÍNIO TELESCÓPICA



REPOSIÇÕES DISPONÍVEIS

Capacidade	150Kg
Dimensões dobradas	300x1090x900mm
Comprimento mínimo	1090mm
Comprimento máximo	1750mm
Altura mínima	550mm
Altura máxima	930mm
Material	Al
Conformidade com a diretiva europeia	EN131
Peso	16,65Kg
Dimensões (CxLxA)	300x1750x900mm

50656

290,00€



JOGO 2 PLATAFORMAS DE ALUMÍNIO



REPOSIÇÕES DISPONÍVEIS

Capacidade	100Kg
Dimensões da plataforma grande (CxLxA)	1300x300x550mm
Dimensões da plataforma grande dobrada (CxLxA)	1300x300x140mm
Dimensões da plataforma pequena (CxLxA)	1000x300x300mm
Dimensões da plataforma pequena dobrada (CxLxA)	1000x300x140mm
Material	Al
Contém	11897, 15552
Conformidade com a diretiva europeia	EN131
Peso	10,45Kg

50913

229,00€

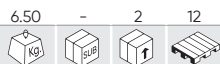

PLATAFORMA DE ALUMÍNIO GRANDE



Capacidade	100Kg
Material	Al
Conformidade com a diretiva europeia	EN131
Dimensões (CxLxA)	1400x300x800mm
Peso	6,50Kg
Dimensões dobradas	1400x300x14mm

54789

34,00€

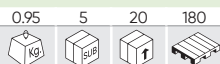

NEW

PROTECTOR FRONTAL PARA CARRO



Material	Poliéster/Polyester
Peso	0,95Kg
Dimensões dobradas	330x50x210mm
Dimensões montadas	4050x725mm

51622

27,00€



PROTECTOR MAGNÉTICO DE COBERTURA DE ALETAS E FACHADAS



Tipo	Imantado/Magnetized
Material	PVC
Peso	0,45Kg
Dimensões (CxA)	1300x640mm

53922

35,00€

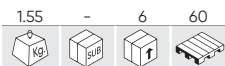

SUPORE DE PAPEL PARA PAREDE



Material	Acero inoxidable/Stainless steel
Altura mínima	480mm
Altura máxima	690mm
Rolo de papel	380mm
Dimensões dobradas	450x270x480mm
Peso	1,55Kg
Dimensões (CxLxA)	4550x210x690mm

PAPEL NÃO INCLUSO

53921

39,00€



PORTA ROLO DE PAPEL



Material	Acero inoxidable/Stainless steel
Altura	975mm
Rolo de papel	380mm
Peso	1,85Kg
Dimensões (CxLxA)	450x345x975mm

PAPEL NÃO INCLUSO

CABO EXTENSÍVEL MULTIFUNÇÃO

REF.	MIN.	MAX.	KG	CM	CM	CM	€
52497	1200mm	530mm	0.29	6	48	480	27,00€
53196	1600mm	710mm	0.37	6	48	384	33,00€



53221

5,00€

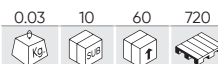

JOGO DE 3 CAMURÇAS DE MICROFIBRAS



Peças	3
Cor	Verde/Green
Material	PL
Medida	360x360mm

55066

319,50€



NEW

LIXADEIRA ELÉTRICA 150 MM 400W



Tensão	220V
Potência	400W
Frequência	50Hz
Velocidade nominal	4000-10000RPM
Diâmetro do disco	150mm
Órbita de lixamento	5mm
Comprimento do cabo	3m
Peso	1,10Kg
Dimensões (CxLxA)	310x150x110mm

54556

74,00€

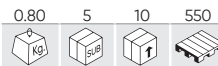

LIXADEIRA DE CINTA 3/8"



REPOSIÇÕES DISPONÍVEIS



Entrada de ar	1/4"
Velocidade nominal	18000RPM
Consumo real de ar	113L/min
Pressão do trabalho	6,2BAR
Intensidade do som	89dB
Órbita de lixamento	10x330mm
Órbita de lixamento	60x80x120mm
Ângulo	90°
Peso	0,80Kg
Dimensões (CxLxA)	290x100x50mm

55025

120,00€

1.80 1 4 36

NEW

PISTOLA DE SECAGEM ELÉTRICA



Tensão	220V ~ 50Hz
Potência	1350W
Comprimento do cabo	5M
Taxa de fluxo de ar	93 CFM
Aceleração máxima de ar	22000ft/min
Peso	1,80Kg
Dimensões (CxLxA)	270x140x280mm

60071

140,00€

0.80 - 10 120

NEW

SOPRADOR DE AR A BATERIA PARA SECAGEM DE VEÍCULOS



Tensão	20V
Fluxo de ar	55m/s
RPM (rotações por minuto)	22500-35000
Taxa de fluxo de ar	10,4CFM (294L/min)
Diâmetro	2,5"
Compatível com	60013, 60015
Peso	0,80Kg
Dimensões (CxLxA)	168x116x255mm

54771

279,00€

7.60 - 1 16

ASPIRADOR PARA ESTOFOS 20L (SECO+HÚMIDO)



REPOSIÇÕES DISPONÍVEIS

Tensão	230V
Potência	1200W
Frequência	50Hz
Capacidade	20L
Litros de sucção por segundo	26L/s
Intensidade do som	82dB
Potência de sucção	17-18KPa
Proteção IP	4
Dimensões (CxLxA)	390x340x460mm
Peso	7,60Kg



53947 149,00€



LAVADORA DE ALTA PRESSÃO 1400W



REPOSIÇÕES DISPONÍVEIS



Tensão	230V
Potência	1400W
Frequência	50Hz
Pressão do trabalho	70-105BAR
Fluxo máximo de operação	5,5-6,8L/min
Temperatura de trabalho	50°C
Proteção IP	IPX5
Peso	5,80Kg
Dimensões (CxLxA)	280x255x440mm

53948 324,00€



LAVADORA DE ALTA PRESSÃO 2400W



REPOSIÇÕES DISPONÍVEIS



Tensão	230V
Potência	2400W
Frequência	50Hz
Pressão do trabalho	120-180BAR
Fluxo máximo de operação	5,5-8L/min
Temperatura de trabalho	50°C
Proteção IP	IPX5
Peso	12,10Kg
Dimensões (CxLxA)	440x345x505mm

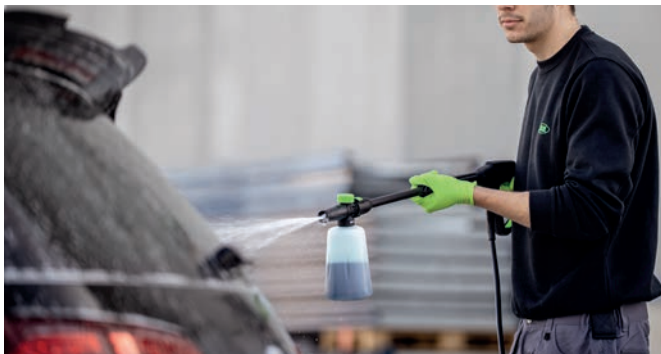

54805 478,00€



NEW

CONJUNTO DE CANDEEIROS DE TECTO HEXAGONAIS

Brilho	83640Lm
Potência	615W
Eficiência	110-120Lm/W
Tensão	185-240V
Tipo de LED	2835
Número de LEDs	12
Temperatura de cor do LED	6500k
Material	Al + PC
Comprimento do cabo	1,5m Enchufe europeo/ EU Plug
Proteção IP	IP45
Peso	8,00Kg
Dimensões (CxLxA)	2435x42x4845mm

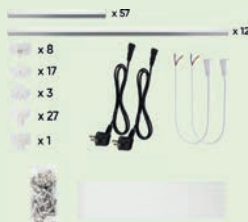

REPOSIÇÕES DISPONÍVEIS

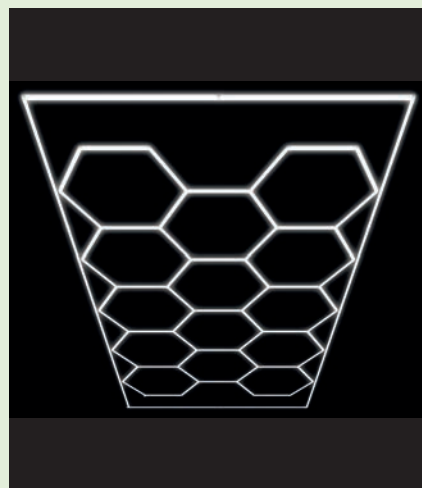



54346

12,80€



CONJUNTO DE 3 ESCOVAS DE LIMPEZA PARA BERBEQUIM



Peças	3
Tamanho do eixo	1/4"
Diâmetro	50, 88, 100mm

54912

7,90€

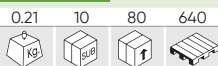

NEW

CONJUNTO PROFÍSSIONAL DE LAVAGEM DE CARRO 4 EM 1 PARA INTERIOR E EXTERIOR



Peças	4
Material	PP
Comprimento da trincha	220, 225, 230, 240mm
Peso	0,21Kg

54895

16,80€



NEW

KIT DE DETALHAMENTO AUTOMOTIVO COM 7 ACESSÓRIOS ESSENCIAIS



Peças	7
Material	PP
Comprimento da trincha	220, 225, 230, 240mm
Diâmetro da cabeça	50, 88, 100mm
Tamanho do eixo	1/4"
Peso	0,35Kg

50844

65,00€

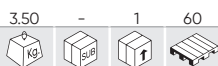

BANCO DE AÇO



Material	Acero/Steel, PVC
Capacidade	115Kg
Altura	380mm
Peso	3,50Kg
Dimensões (CxLxA)	360x375x380mm

54682

54,00€

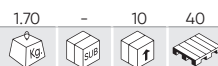

PLATAFORMA MÓVEL DE AJOELHAMENTO



Material	Polipropileno/Polypropylene
Carga máxima	100Kg
Peso	1,7Kg
Dimensões (CxLxA)	500x255x85mm

53191

14,80€



ESTRADO EM ESPUMA



Material	Espuma EVA/EVA foam
Peso	0,15Kg
Dimensões (CxLxA)	480x180x320mm

TRAVÕES

232 REPOSICIONADORES

235 SANGRADORES DE TRAVÕES

237 MANUTENÇÃO



54584

134,00€



CONJUNTO DE FERRAMENTAS DE PISTÃO DE TRAVÃO

- _____ Ferramenta de reposicionamento da pinça de travão
- _____ Fuso 2 em 1 direito e esquerdo com pega
- _____ Contraplaca (Ø90mm)
- _____ Fuso pneumático para adaptadores de pistão de travão (260mm)
- _____ Adaptador de 3/8" (9,5 mm) para ferramenta de pistão de travão com iman
- _____ Adaptador universal regulável com 2 pinos
- _____ Adaptador universal regulável com 3 pinos



REPOSIÇÕES
DISPONÍVEIS



52636

119,00€

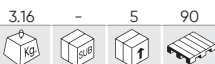

CONJUNTO DE RECOLHA DE EMBOLOS DE TRAVÕES PNEUMÁTICO - 18PCS

- 0** General Motors (Ø pistões 2-1/2 pol.)
- 2** Citroën XM/Xantia (F/R), HONDA
Audi (F), Fiat, Alfa romeo (F), Ford Fiesta (F), Isuzu (F), Honda Concesto (F), Jaguar XJ6/
XJ40 (F/R), BMW 318is / 320i / 325T / 518i / 525i-1x / 740i / 850ci / M5 (F), Mercedes BENZ
190/200/300/420/560 serie (F), Mitsubishi Colt (F), Nissan Miera/Stanza/Sunny (F), Rover
Austin/Metro200-400 series/Maestra/Montego (F), Toyota Camry (F), Volvo (F), VW Passat/
Golf GTI (F)
- 3** Ford Australia/NZ Telstar, Mazda (R), Saab 9000 (R)/Lumina, Toyota, Fiat 164 2.0 (R), Alfa
Romeo Prelude/CRS 16i, Honda Saturn (R)/Grand Prix, GM
- 4** Adaptador 3/8"
- 6** Nissan Primera, VW Golf IV
Audi 80/90/V8+100/Coupe E (R), Rover 800 ABS, Subaru L+Z (R), Ford Sierra ABS/Granada/
Scorpio ABS (R), Nissan Bluebird 1.8 Turbo/Silvia Turbo/Primera2.0i LS-GS-GSX (R), Peugeot
405 1.9Gi/Gri/Sri/Gtxi/MI 16/605 2.0 Sri (R), Toyota Cecilia/Corolla GT/MR2 (R), VW Golf Gti/
Jetta Synchro/ Jetta Gti 16v, Passat CL, GL, GT, GT 16v, Corrado 16V scirocca GTX 16V(R), Citroën,
Alfa romeo, Fiat, Honda, Jaguar, Renault, Saab, Seat, Lancia
- 8** General Motors (pistões de 1-7/8 pol.)
- 9** General Motors (Ø pistões 2-1/8 pol.)
- A(Z)** Renault (R21-Laguna (R))
- E** Nissan Maximas/Cefiro
- F(G)** Opel (Rear disk)/ Fiat Stilo
- K** Citroën C5
- K1** Renault, Citroën C5
- K2** Renault, Citroën, Audi A8, S8
- M** Ford, Mini Cooper, Nissan Primera 03
Saab, Honda, Alfa Romeo 164 2.0 Twin Spark/2.0 Turbo (88-)/3.0 V6, Audi 200 (80-)/ Coupe
GT SE (82-)/80/90/1Q0/200/Quattro (87-)/90/20V (88-), Ford Mondeo 2.0/Ghia, Lancia
Themaalte (85-), Volkswagen Golf II GTI (83-87)/Sirocco 16V (84)
- N**

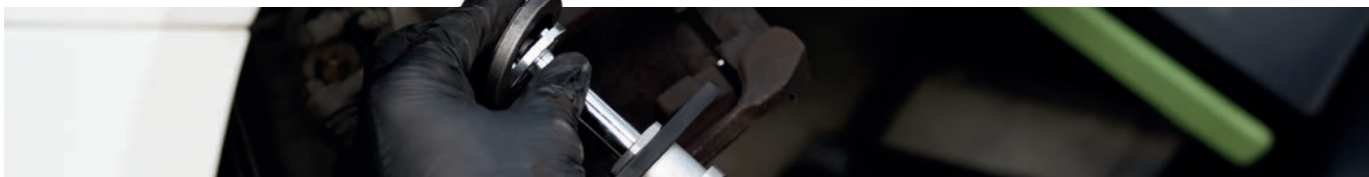

53978

38,90€

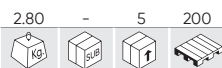

CONJUNTO DE REPOSICIONADOR DE TRAVÕES 23 PEÇAS

0	General Motors (Ø pistões 2-1/2 pol.)		
1	Disco		
2	Citroën XM, Xantia		
3	Alfa Romeo, Audi, Austin, BMW, Ford, Honda, Jaguar, Mercedes-Benz, Mitsubishi, Nissan, Rover, Toyota, VW		
4	Alfa Romeo 164 2.0, Ford, Mazda, Saab 9000, Subaru		
5	Adaptador 3/8"		
6	Nissan Primera, VW, Golf IV		
7	Audi 80;90;V8+100, Ford Sierra ABS+Scorpio de 1985, Honda Prelude, Nissan Silvia 1.8 turbo, Rover 8000, Saab 9000, Subaru L+Z, VW Golf + Passat		
8	General Motors (pistões de 1-7/8 pol.)		
9	General Motors (Ø pistões 2-1/8 pol.)		
10	VW	K1	Citroën
A	Renault R21, Laguna	K2	Citroën
E	Nissan Maxima, Cefiro	M	Ford
F	Opel	N	Saab, Honda
K	Citroën C5	O	Disco

J Fiat Tipo TD 16V, Uno Turbo(85) Crama TD, Honda CRX, Alfa Romeo 155 1.8-2.01, 164 TD (93), 164 3.0 V6 (91); Audi 80, 90, & V8's, A3, A4, A6, A8 (pinza trasera); Citroën ZX 2. Ql 16v; Fiat Tipo TD 16V, Uno Turbo (85-), Crama TD; Ford Sierra (ABS bak), Granada (85-); Ford (Australia & NZ) Thunderbird Turbo; Honda CRX, 1.6l-16V (88-90), Accord 1800 (84-85), 2.0i (86-), Preludi 16V (88-), LegendV6; Jaguar XJ serie 40; Lancia Dedra. 2.0 Ei Tur(93), Delta 1.6 Gti. (92), The. majE 16v(92), Thema. 2000 Turbo. Kappa 2.Q-2.4LS, 2.4TD.



51059

99,00€



CONJUNTO REPOSICIONADOR DE TRAVÕES

0	Disco
1	Disco
2	Citroën XM, Xantia (F/R)
3	Alfa Romeo, Audi, Austin, BMW, Ford, Honda, Jaguar, Mercedes-Benz, Mitsubishi, Nissan, Rover, Toyota, VW
4	Alfa Romeo 164 2.0, Ford, Mazda, Saab 9000, Subaru
5	Adaptador 3/8"
6	Nissan Primera, VW-Golf IV
7	Audi 80, 90, V8 +100, Ford Sierra ABS+Scorpio ab 85,Honda Prelude Nissan Silvia 1.8 turbo, Rover 8000, Saab 9000, Subaru L+Z, VW-Golf +Passat
8	General Motors (pistões de 1-7/8 pol.)
9	General Motors (Ø pistões 2-1/8 pol.)
11	Disco para Tipo S
12	Disco para BMW mini
A	Disco de dois pinos 1-3 / 16 " para Renault R21, Laguna
B	Ford, Lincoln, Subaru
C	Mini Austin
D	Citroën, Renault
E	Cefiro, Maxima
F	Opel Corsa, Astra, Zafiraand Vectra
G	Opel (disco traseiro)

Alfa Romeo 155 1.8-2.0 164 TD(93) 164 3.0 V6(91) Audi, 80, 90, A3, A4, A6, A8 Citroën ZX 2 Ql 16V, Fiat Tipo TD 16V, Uno Turbo(85) Crama TD, Ford Sierra(ABS bak), Granada (85), (Australia & NZ) Thunderbird Turbo, Honda CRX, 1.6l-16V (8-90), Accord 1800(84-85)2.0i, Prelude 16V(88), Legend V6, Jaguar XJ40series, Lancia Dedra 2.0 Ei Tur(93), Delta 1.6Gti, Nissan, Peugeot, Renault, Seat, Subaru, Volvo V40 & S40

K	Citroën C5
K1	Citroën, Renault
K2	Citroën, Renault
M	Ford
N	Saab, Honda
O	GM Motors
P	Audi, BMW, Ford, Lancia, Proton, Renault, Rover, VW



R	Ford (Australia & NZ) Telstar, Laser, Mazda 323 Gti,GTX(86-), 929(82-), RX7(81-), 626 16V (87-), 626 GT (86-),929 V6(88-), Mitsubishi Galant GL Si, Toyota Celica, Corolla GT, MR2
S	Audi 100TQi(91), BMW 740i 8cyl.(91), Lancia Delta 1.9 TD(95), Proton 416, Renault-most models, Renault Laguna 2.0 (94), Laguna 2.2 D(95), Safrane 2.0-2.2 TD V6, Rover 623 Si, Volkswagen Golf Gti Mk 3&4, Passat VR6,Vento GT(92)
Z	BMW, Mini
	Grampo de rotação direita (com rosca à direita)
	Grampo de rotação esquerda (com rosca à esquerda)
	Pin Ø 3.0 / Pin Ø5.5 (100g Grasa)

52330

99,00€



CONJUNTO REPOSICIONADOR DE TRAVÕES 50 PEÇAS

- 0 General Motors (Ø pistões 2-1/2 pol.)
- 1 Disco
- 2 Citroën XM, Xantia u.a.
- 3 Alfa Romeo,Audi, Austin, BMW, Ford, Honda, Jaguar, Mercedes-Benz. Mitsubishi, Nissan Rover, Toyota, VW
- 4 Alfa Romeo 164 2.0.Ford, Mazda, Saab 9000, Subaru
- 5 Adaptador 3/8"
- 6 Nissan Primera, VW-Golf IV
- 7 Audi 8.0,9.0,V8 +100, Ford Sierra ABS+ Scorpio ab 85, Honda Prelude, Nissan Silvia 1.8 turbo, Rover 8000, Saab 9000, Subaru L+Z, VW-Golf+ Passat
- 8 General Motors (pistões de 1-7/8 pol.)
- 9 General Motors (Ø pistões 2-1/8 pol.)
- 11 Disco para Tipo S
- 12 Disco para BMW mini
- A Nissan Primera 2.0, Bluebird
- A1 Ford Transit 06,Transit Connect 02,Tourneo Connect 02,Mondeo 00-07,C-Max 03, Focus 04
- B Ford, Lincoln, Subaru
- B1 Ford S-max 06,Scorpio 94-06,Mondeo 07,Kuga 08,Galaxy 00-06,Focus RS 03,Fiesta 01-02,Cougar 98-01
- C Nissan Primera (02), Opel Vectra 02-,Toyota Avensis
- D Citroën, Renault
- E Cefiro, Maxima
- F Peugeot 206 CC/Hdi/Gti. Ela exige uma chave de 16mm com pistões traseiros
- F1 Fiat Ducato
- G Opel
- G1 Volkswagon Golf V / VI
Alfa Romeo 155 1.8-2.0 164 TD(93) 164 3.0 V6(91), Audi 80,90,A3,A4,A6,A8, Citroen ZX 2 Ql 16V, Fiat Tipo TD 16V, Uno Turbo (85) Crama TD, Ford Sierra (ABS bak). Granada (85) Crama TD, Ford Sierra (ABS bak). (Australia& NZ) Thunderbird Turbo, Honda CRX, 1.6l-16V (8-90). Accord 1800 (84-85) 2.0i. Prelude 16V (88), Legend V6, Jaguar XJ 4, Oseries, Lancia Dadra 2.0, Ei Tur (93), Delta 1.6 Gti, Nissan, Peugeot, Renault, Seat, Subaru, Volvo V40 &S40.
- K Citroën C5
- K1 Citroën
- K2 Citroën, Renault
- M Ford
- N Saab, Honda
- O Disco
- P Audi, BMW, Ford, Lancia, Piston, Renault, Rover.
- P1 Peugeot 307, 308



- Alfa Romeo 164 2.0 1., Fiat Uno, Turbo ie-Barchetta, Ford Escort MK III, IV, Orion, XR31,
- Q Focus(98-) push-back pistons, Honda-most models (push-back pistons), Rover-most models(push-back pistons), Subaru Lserie & Serie 2
- Rover(Australia& NZ) Teslar, Laser, Mazda 323 Gti, GTXX (86), 929 (82_), RX7(81-), 626
- R 16V(87-) 626 GT (86-), 929 V6 (88-), Mitsubishi Galant GL Si, Toyota Celica, Corolla GT, MR2
- Audi 100 TQ(91), BMW 740i 8cyl (91), Lancia Delta 1.9 TD (95). Proton 416. Renault-most models, Renault Laguna 2.0 (94), Laguna 2.2 D (95) Safrane 2.0-2.2 TD V6, Rover 623 Si, Volkswagen Golf Gtu Mk I&IV, Passat VR6, Vento GT (92)
- T Rover 220 C Turbo (95)
- V Rover 216 Gti 16V,820 Si 2.0(93),825 SD 2.5 (93)
- Z Renault
- IV Iveco Daily, Volkswagon Passat 2.0 TDI 09

52906

38,00€

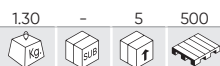

CONJUNTO DE REPOSICIONADOR DE TRAVÕES UNIVERSAL

- Adaptador de 2-PINS ajustável do pistão do freio
- Adaptador de 3-PINS ajustável do pistão do freio
- Haste roscado central
- Manivela
- Adaptador móvel
- A parte central móvel
- Alfa Romeo 164 2.0, Ford, Mazda, Saab 9000, Subaru, Nissan Primera, VW, Audi, Ford Sierra Abs + Scorpio Ab 85, Honda Prelude, Nissan Silvia 1.8 Turbo, Rover 8000, Saab 9000, Ford, Opel, BMV, Lancia, Proton, Renault, Rover, Peugeot 307, 308 A3- Iveco Daily, Volkswagon Passat 2.0 Tdi 09, Renault Laguna.



REPOSIÇÕES DISPONÍVEIS

53683

116,00€

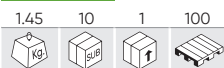

PISTOLA PARA POSICIONAR FREIOS - PERFIL BAIXO



Pressão do trabalho	5-8BAR
Pressão de ar máxima	14BAR
Entrada de ar	1/4"
Magnetizado	Si/Yes
Peso	1,45Kg
Dimensões (CxLxA)	313x275x80mm

51283

78,00€



PISTOLA PARA POSICIONAR FREIOS



Pressão do trabalho	5-8BAR
Pressão de ar máxima	14BAR
Entrada de ar	1/4"
Peso	1,33Kg
Dimensões (CxLxA)	298x277x77mm

52315

16,00€

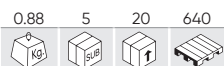

SEPARADOR DE EMBOLOS DE TRAVÕES



Abertura	80mm
Material	CSTL
Peso	0,88Kg
Dimensões (CxLxA)	170x160x65mm

54589

31,50€



ADAPTADOR UNIVERSAL PARA PURGADOR DE TRAVÕES



Pressão máxima	3,5BAR
Comprimento	114-180mm
Conexão rápida	3/8"
Diâmetro	28-70mm
Peso	0,48Kg

54588

499,00€

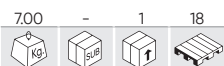

PURGADOR DE TRAVÕES ELÉTRICO

Pressão do trabalho	0,6-3,0BAR
Tensão	12-24V DC / 110-220V AC
Potência	48W
Adaptadores	16
Caudal	2,2LPM
Peso	7,00Kg
Dimensões (CxLxA)	240x200x280mm



REPOSIÇÕES DISPONÍVEIS VÍDEO TUTORIAL

54903

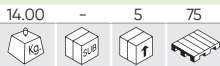

NEW

CONJUNTO DE ADAPTADORES PARA SANGRADORES DE TRAVÕES

1	Benz, BMW, Audi, Škoda, Fiat, Lexus, Land Rover, Jaguar, Porsche, Buick, Ford, Chevrolet, Volvo, Citroën, Volkswagen, Peugeot, Renault		
2	Mitsubishi, JAC, Hyundai, Infiniti, Subaru, Renault, Kia Series, BAIC BJEV		
3	Buick Business Series	10	Nissan Series
4	Ford Focus, Ford Edge, Audi, Peugeot	11	Wuling
5	Honda Series	12	Suzuki, Changan
6	Toyota Series	13	Soueast DX5, Soueast DX7
7	Cadillac, Ford Fiesta, Buick, Mazda	14	Nissan: Teana, Qashqai, X-Trail
8	Dodge, Chrysler, Jeep Series	15	Mitsubishi, Soueast, Lingyue
9	Dongfeng, Fengxing Series	16	Tesla
Conector rápido / Quick Connector			
Adaptador universal / Universal Adapter			



179,00€

60067



NEW

SANGRADOR DE FREIOS ELÉTRICO A BATERIA

Pressão do trabalho	0,6-3,0BAR
Tensão	12-24V DC / 110-220V AC
Potência	48W
Adaptadores	17
Caudal	2,2LPM
Compatível com	60012, 60013, 60015
Peso	7,50Kg
Dimensões (CxLxA)	240x200x280mm



REPOSIÇÕES DISPONÍVEIS

515,50€

52191

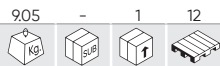

SANGRADOR DE TRAVÕES

Peças	16
Pressão do trabalho	0-4BAR
Entrada de ar	1/2"
Adaptadores	11+2 Adaptadores universales/Universal adapters
Peso	9,05Kg
Dimensões (CxLxA)	385x385x460mm



REPOSIÇÕES DISPONÍVEIS



VÍDEO TUTORIAL



198,00€

52275 38,00€

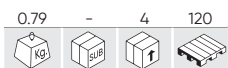

SANGRADOR DE TRAVÕES



Peças	5
Capacidade	0,75L
Pressão do trabalho	6-12BAR (87-174PSI)
Entrada de ar	1/4"
Consumo real de ar	180L/min
Peso	0,79Kg
Dimensões (CxLxA)	280x210x130mm

55051 59,00€



NEW

KIT SANGRADOR DE FREIOS MANUAL



Pressão do trabalho	0,7-2,0BAR
Material	ABS
Adaptadores	Coches europeus/European cars
Capacidade	3,00L
Dimensões (CxLxA)	165x160x400mm

54721 67,00€

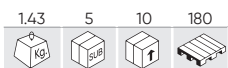

CONJUNTO DE CHAVES DE SANGRIA DE TRAVÃO



Peças	7
Medida	7, 8, 9, 10, 11, 12mm
Peso	1,43Kg
Dimensões (CxLxA)	350x25x65mm

54016 76,00€



BOMBA DE COMPROVAÇÃO DE PRESSÃO



Peças	20
Nível de vácuo	-0,75BAR (-20PSI)
Pressão de ar máxima	3BAR (40PSI)
Peso	1,50Kg
Dimensões (CxLxA)	345x90x240mm

54372 157,00€

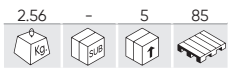

CONJUNTO DE TESTADORES DE TRAVÕES COM E SEM ABS

- x1 Adaptador Teves
- x1 Encaixe Giratório de 45°
- x1 Encaixe Giratório de 90°
- x2 Encaixes Retos de 7/16-24 de polegada
- x2 Encaixes Retos de 1/4-28 de polegada
- x2 Encaixes Retos de 3/8-24 de polegada
- x2 Encaixes Retos de 5/16-24 de polegada
- x2 Encaixe Reto M10-1,5
- x2 Encaixe Reto M8-1,25
- x2 Adaptador de Drenagem M10-1,0
- x2 Encaixes Retos de 7/16-20 de polegada
- x2 Encaixe Reto M7-1,0



Audi (TT (2007-), A4 (2001-), A6 (2005-), A8 (2003-), Q7, S5, S6, S8, Porsche (Cayenne, Macan, Cayman), Mercedes-Benz (ML320, Classe C), Ford (Mondeo, Fiesta, Focus, Edge), BMW (Series 3 -geração E36 / 5), Alfa Romeo, Jaguar (XF), Vauxhall, Volkswagen, Chrysler, Mini, SAAB



54135

82,00€

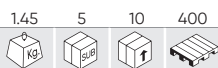

KIT DE CHAVES DE CAIXA PARA PINÇA DE TRAVÃO



14x38, 22x38mm	x2
11,50x38, 15x38, 20x38mm	x3
10, 12.50, 14, 19mm	x4
10mm	x1
H11x100, H7x70, H7x92, H9x50mm	x4
7x24, 8x24mm	x2
9x20mm	x1

Audi (A4, A5, S5, S8, Q5, Q7), Porsche (Cayenne, Macan, Cayman), Mercedes Benz, Ford, BMW, Alfa Romeo

54887

64,00€



NEW

CONJUNTO DE ADAPTADORES DE PURGA DE TRAVÕES PARA TESLA

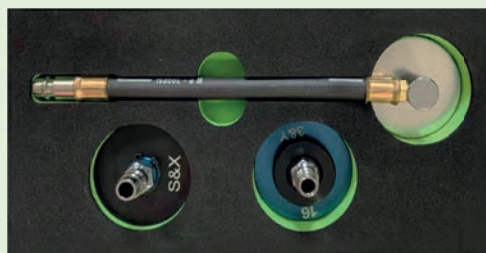

Entrada de ar	1/4"
Compatível com	Model 3, S, X, Y
Adaptadores	3
Peso	0,46Kg
Dimensões (CxLxA)	240x120x65mm

52434

125,00€

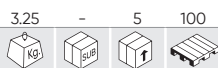

KIT PARA REPARAÇÃO DE TRAVÕES

Chaves para porcas de freio	x2
Alicate de mola de freio	x1
Chave de fenda de impacto	x1
Soquetes de chave de fenda	x3
Ferramenta de montagem	x1
Chave de fenda com articulação universal	x1
Ferramenta de freio especial	x1
Escova de limpeza	x1
Escova para limpeza de latão	x1
Ferramenta de montagem	x1
Alicate para cabo de freio	x1
Arquivo de pinça de freio	x1



52625

9,00€

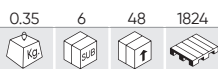

ALICATE PARA MOLAS DE TRAVÃO



Abertura	195mm
Material	CSTL
Comprimento	310mm
Peso	0,35Kg

52455

16,00€



APALPA FOLGAS PARA PASTILHAS DE TRAVÕES



Peças	8
Medidas	2, 3, 4, 5, 6, 8,10, 12mm
Material	ABS
Peso	0,26Kg
Dimensões (CxLxA)	200x155x30mm

51839

24,00€

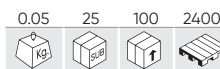

COMPROVADOR DE FLUÍDO DE FREIO



Bateria	1 Pila/Battery AAA
Peso	0,05Kg
Dimensões (CxLxA)	215x127x35mm

FERRAMENTA ESPECIAL

- 240 SISTEMA DE LUBRIFICAÇÃO
- 247 SISTEMA DE INJETORES
- 252 CILINDROS
- 262 EMBREAGEM
- 263 SISTEMA DE REFRIGERAÇÃO
- 266 SISTEMA DE AR CONDICIONADO
- 269 TRANSMISSÃO
- 270 SUSPENSÃO/DIREÇÃO
- 281 ESCAPE
- 282 SISTEMA ELÉTRICO
- 285 REPARAÇÃO DE ROSCAS
- 287 MOTOS
- 287 EXTRATORES
- 298 DESMULTIPLICADORES DE FORÇA



54068

120,00€

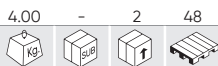

KIT DE CHAVES PARA FILTROS DE ÓLEO DE ALUMÍNIO, 19 PÇS



REPOSIÇÕES DISPONÍVEIS

Nº DE PEÇAS	FACES	Ø
05101 Mazda, Mitsubishi	15	100,5mm
0595 Nissan, Toyota	15	94,5mm
0592 Nissan, Subaru	15	92mm
0579 Toyota, Honda, Mitsubishi, Subaru, Mazda, Lsuzu	15	79mm
915 Volvo	16	87mm
901L Lexus	14	79,5mm
901T Toyota	14	70mm
901-1 Toyota	14	63-64mm
902 Ford, Mazda	14	66,5mm
1284 Mercedes Benz, Dodge, Jeep	14	84mm
903B Mercedes Benz	14	74mm
24mm BMW, Saturn, Opel, Chrysler, Jeep	6	24mm
27mm Mercedes Benz	6	27mm
30mm Audi, Volkswagen	6	30mm
32,5mm Opel, BMW, Audi, Volkswagen	6	32,5mm
36mm Opel, BMW, Mercedes Benz, Volkswagen	6	36mm
38mm Opel	6	38mm
917 Universal		55-90mm



51332

98,00€



KIT DE EXTRACTORES PARA FILTROS OLEO



REPOSIÇÕES DISPONÍVEIS

Nº DE PEÇAS	FACES	Ø
901 Toyota, Nissan, Fiat Daihatsu	14	65mm
902 Toyota, Daihatsu	14	67mm
903 VW, Mercedes, BMW, Opel, Audi	14	74mm
903-1 GM/AC, Wix, Ford, Isuzu	15	75mm
903-2 VW, Audi, Seat, BMW, Renault	8	74mm
903-3 Audi, Rover, Chrysler	15	74mm
903-4 Toyota, Lexus	14	73mm
903-6 Schlepper, Baumashinen	12	75mm
918 Rover, Chrysler, Audi	15	74mm
904 Nissan, Ford	15	79mm
905 GM, Chrysler	15	73mm
905-1 BMW, Mercedes, Opel, Audi, VW	14	74mm
906 Baumashinen, Schlepper	18	84mm
907 Mitsubishi, Toyota	15	89mm
908 Nissan, Toyota	15	91mm
915 Honda Accord, Mitsubishi, Isuzu	15	90mm
910 Toyota, Alfa Romeo, Ford	15	95mm
911 Fiat, Renault, Citroën	12	80mm
911-1 Subaru, Toyota, Honda, Nissan	15	80mm
914 Mazda, Toyota	15	101mm
909 Isuzu, Nissan	15	92mm



CHAVE EXTRAÇÃO PARA FILTROS DE ÓLEO

REF.	DESCRIÇÃO							€
52311	CHAVE EXTRAÇÃO PARA FILTROS DE ÓLEO 42MM	VAG	0.13	6	72	1728	20,50€	
52312	CHAVE DE EXTRAÇÃO PARA FILTROS DE ÓLEO 74X14C	VW, OPEL, MERCEDER, BMW, AUDI	0.10	10	100	1000	9,00€	
52313	CHAVES DE EXTRAÇÃO DE FILTROS DE ÓLEO 86X16C	VOLVO	0.20	6	68	1008	8,00€	
52314	CHAVES DE EXTRAÇÃO DE FILTROS DE ÓLEO 87X16C	BMW, VOLVO	0.20	5	50	400	26,60€	
52809	EXTRACTOR PARA FILTRO DE ÓLEO - TOYOTA	TOYOTA	0.15	10	100	1000	8,50€	
53441	CHAVE EXTRAÇÃO PARA FILTROS DE ÓLEO 76X14C	-	0.20	5	20	720	9,80€	



52311



52312



52313



52314



52809



53441

52615

112,00€



EXTRATOR PARA FILTRO DE ÓLEO - 9 PEÇAS

1/2"	x1	Universal	63 - 83mm
		Mercedes Benz, Smart	27mm
x3		GM, Opel, Vauxhall, Mercedes Benz	32mm
		Mercedes Diesel, BMW, Mini, Ford	36mm
		Toyota (Allion, Auris, Corolla, Prius, Voxy, etc.)	64,5mm
3/8"	x3		Toyota, Lexus (6 Zyl.)
		Audi, BMW, Ford, Toyota, Volkswagen, Porsche, Mercedes-Benz	74,2mm
	x1		Hyundai, Kia
	x1		BMW 3+5+X, Volvo



53008

15,50€



EXTRATOR PARA FILTRO OLEO FORD, CITROËN, PEUGEOT 2.0, 2.2 HDI, TDCI



Marcas	FORD, CITROËN, PEUGEOT
Material	CrMo
Medida	27mm
Medida do quadrado	1/2"
Peso	0,60Kg
Dimensões (CxLxA)	310x125x20mm

52518

115,00€

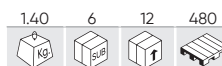

EXTRACTOR DE FILTROS DE CAMION



Marcas	Universal
Material	CSTL, CrMo
Diâmetro	95-165mm
Medida do quadrado	1/2"
Peso	1,40Kg

51352 9,80€

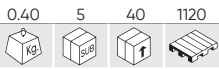

EXTRATOR PARA FILTRO DE ÓLEO DE PATILHA PLANA



Marcas	Universal
Material	CSTL
Diâmetro	57-118mm
Medida do quadrado	3/8"-1/2"
Peso	0,40Kg

51353 11,50€

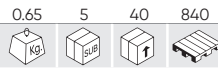

EXTRATOR PARA FILTRO DE ÓLEO DE PATILHA REDONDA



Marcas	Universal
Material	CSTL
Diâmetro	72-136mm
Medida do quadrado	3/8"-1/2"
Peso	0,65Kg

51934 11,50€



EXTRATOR FILTRO DE ÓLEO DE PATILHA PLANA MAGNETIZADO



Marcas	Universal
Material	CSTL
Diâmetro	57-118mm
Medida do quadrado	3/8"-1/2"
Magnetizado	Si/Yes
Peso	0,40Kg

51923 13,00€

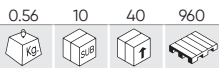

EXTRATOR FILTRO DE ÓLEO DE PATILHA REDONDA MAGNETIZADO



Marcas	Universal
Material	CSTL
Diâmetro	72-136mm
Medida do quadrado	3/8"-1/2"
Magnetizado	Si/Yes
Peso	0,56Kg

54542 23,00€

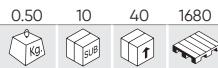

EXTRATOR DE FILTRO DE ÓLEO AJUSTÁVEL (60-80MM)



Marcas	Universal
Material	40Cr
Diâmetro	60-80mm
Medida do quadrado	1/2"
Peso	0,47Kg

54543 37,00€

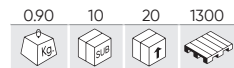

CHAVE AJUSTÁVEL PARA FILTRO DE ÓLEO (80-105 MM)



Marcas	Universal
Material	40Cr
Diâmetro	80-105mm
Medida do quadrado	1/2"
Peso	0,86Kg

55014 64,00€

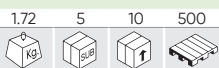

NEW

CHAVE PARA FILTRO DE ÓLEO AJUSTÁVEL (105-145 MM)



Marcas	Universal
Material	40Cr
Diâmetro	105-145mm
Medida do quadrado	1/2"
Peso	1,66Kg

53206 39,00€



CONJUNTO DE 5 VARAS PARA VERIFICAR O ÓLEO - BENZ/AUDI

	920mm - Código de transmissão: 716.5,722.7,722.8.
	Mercedes-Benz 930mm - Ano de fabrico: 1988-1997. - Códigos do motor: 103,104,111,119,120,137,604,605,606,611,612,613,628,642,647,648.
	930mm - Ano de fabrico: 1996-2005. - Códigos do motor: 103,104,111,112,113,119,120,137,271,272,604,605,606,611,612,613,628,642,646,647,648.
	1200mm - Código de transmissão: 722.6.
	Audi 1160mm - AUDI 100 motores.



REPOSIÇÕES DISPONÍVEIS



51354 13,20€

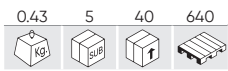

PINÇA EXTRATORA DE FILTROS DE ÓLEO



Marcas	Universal
Material	CrV
Abertura	80-120mm
Peso	0,43Kg

53670 29,50€

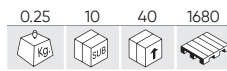

CHAVE DE FILTRO DE ÓLEO PARA VAG DSG 1/2" 24MM



Marcas	VAG
Material	CrMo
Medida	24mm
Medida do quadrado	1/2"
Peso	0,25Kg

54708 17,00€

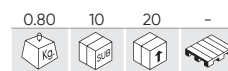

CHAVE DE FILTRO DE ÓLEO DE 12 PONTOS DE 46 MM PARA VW



Marcas	VW
Material	S
Medida	46mm
Peso	0,80Kg
Dimensões (CxLxA)	460x3,5x5,5mm

EXTRATOR DE FILTROS

REF.	DESCRIÇÃO	mm					€
52269	EXTRATOR DE FILTROS DE CINTA	ø 80 - 120mm	0.20	10	50	800	7,00€
52677	EXTRATOR FILTROS AJUSTÁVEL Ø65-105MM	ø 65 - 105mm	0.32	10	40	720	17,00€
52678	EXTRACTOR DE FILTROS AJUSTÁVEL Ø110-155MM	ø 110 - 155mm	0.33	10	40	400	18,00€

52269

REPOSIÇÕES DISPONÍVEIS



52677

REPOSIÇÕES DISPONÍVEIS



52678

REPOSIÇÕES DISPONÍVEIS



EXTRATOR DE FILTROS

REF.	DESCRIÇÃO					€
52416	EXTRATOR FILTROS DE CORRENTE Ø160	0.37	5	50	900	14,00€
52417	EXTRATOR DE FILTROS DE CORRENTE 300MM - Ø160	0.90	5	25	850	28,00€
52607	EXTRATOR DE FILTROS DE CORRENTE Ø60-140MM	0.85	6	24	576	49,00€
52608	EXTRATOR DE FILTROS DE CORRENTE Ø60-195MM	0.95	6	24	480	49,00€



52416



52417



52607



52608

53735

48,00€

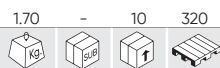

KIT DE CHAVES PARA BUJÃO DE CARTER, 23PCS

	x2	5/16", 3/8"
	x7	7, 8, 10, 11, 12, 13, 14mm
	x1	10mm
	x1	10mm
	x7	8, 9, 10, 12, 13, 14, 17mm
	x1	T45
	x1	M16
	x1	200mm
	x2	75, 150mm



REPOSIÇÕES DISPONÍVEIS



15084

68,00€

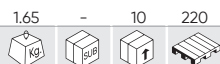

MÓDULO DE EXTRAÇÃO DE TAMPÕES DE CÂRTER



	x2	5/16", 3/8"
	x7	7, 8, 10, 11, 12, 13, 14mm
	x1	10mm
	x1	10mm
	x7	8, 9, 10, 12, 13, 14, 17mm
	x1	T45
	x1	M16
	x1	200mm
	x1	150mm

55004

89,00€



NEW

KIT DE 34 PEÇAS PARA EXTRAÇÃO DE BUJÕES DE CÂRTER



Peças	34
Marcas	Universal
Material	CrV

KIT REPARADOR DE ROSCAS DE TAMPÃO CÂRTER

REF.	DESCRIÇÃO					€
53235	KIT REPARADOR DE ROSCAS DE TAMPÃO CARTER (M-13)	0.25	10	40	1200	10,40€
53236	KIT REPARADOR DE ROSCAS DE TAMPÃO CARTER (M-15)	0.35	10	40	1200	12,00€
53237	KIT REPARADOR DE ROSCAS DE TAMPÃO CARTER (M-17)	0.35	10	40	1200	12,90€
53238	KIT REPARADOR DE ROSCAS DE TAMPÃO CARTER (M-20)	0.40	10	40	1200	18,40€



53235



53236



53237



53238

NEW TAMPAS DO CÁRTER

REF.							€/UNI
54981		CITROËN, FIAT, FORD, LAND ROVER, MAZDA, SUZUKI, VOLVO	0.02	4	500	-	1,00€
54988		FORD	0.04	4	500	-	1,50€
54994		CITROËN, FIAT, HYUNDAI, LANCIA, MAHINDRA, NISSAN, PEUGEOT	0.02	4	500	-	1,50€
54978		CHEVROLET, FIAT, CADILLAC, OPEL	0.02	4	500	-	1,50€
54975		AUDI, VOLKSWAGEN	0.04	4	500	-	1,50€
54979		CITROËN, PEUGEOT	0.05	4	500	-	1,50€
54983		HYUNDAI, KIA	0.04	4	500	-	1,50€
54990		MAZDA	0.04	4	500	-	2,50€
54992		HONDA, HYUNDAI, ISUZU, KIA, LAND ROVER, MAZDA, MG	0.04	4	500	-	1,00€
54991		VAG	0.03	4	500	-	1,50€
54993		FORD, SAAB	0.04	4	500	-	1,50€
54996		AUDI	0.02	4	500	-	1,50€
54995		HONDA, HYUNDAI, MAZDA, MITSUBISHI, PEUGEOT, SUZUKI, OPEL, SMART	0.03	4	500	-	1,00€
54985		CITROËN	0.02	4	500	-	1,50€
54986		ALFA ROMEO, FIAT, JEEP, LANCIA, OPEL, SUZUKI	0.04	4	500	-	3,00€
54989		ALFA ROMEO, FIAT, JEEP, LANCIA	0.06	4	500	-	2,00€
54977		CITROËN, FORD, OPEL, PEUGEOT, TOYOTA, VAU HALL	0.01	4	500	-	2,50€
54980		FORD	0.02	4	500	-	4,00€
54987		CADILLAC	0.01	4	500	-	3,50€

APRESENTAÇÃO EM SACOS DE 4 UNIDADES
 COMPRA MÍNIMA DE 4 UNIDADES



53472

12,00€

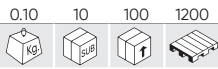

CHAVE PARA BUJÕES DE CARTER DE PLÁSTICO (VAG)



Marcas	VAG
Material	PT, CrV
Medida	14x1,5x22mm
Comprimento	100mm
Peso	0,10Kg
Dimensões (CxLxA)	130x100x25mm

52617

7,00€

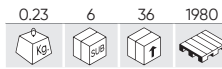

CHAVE QUADRADA PARA BUJÕES



Marcas	CITROËN, RENAULT, PEUGEOT
Material	CrV
Medidas	8-10mm
Comprimento	310mm
Tipo	Cuadrangular/Quadrangular
Peso	0,23Kg
Dimensões (CxLxA)	310x100x12mm

51337

50,00€

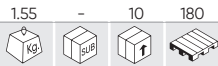

KIT DE REPARAÇÃO DE BUJÕES DE CARTER

	A	M15 x 1.5P		E	M13 x 1.5P
	B	M17 x 1.5P		F	M15 x 1.5P
	C	M20 x 1.5P		G	M17 x 1.5P
	D	M13 x 1.5P		H	M20 x 1.5P



REPOSIÇÕES DISPONÍVEIS



54538

30,00€

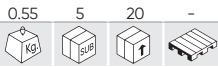

KIT DE REMOÇÃO DE PARAFUSOS DE DRENAGEM DE ÓLEO DE PLÁSTICO (9 UNIDADES)

A	3/8"	FORD
B	3/8"	FORD
C	3/8"	FORD
D	3/8"	FORD, PSA
E	3/8"	MERCEDES
F	3/8"	DAF, MAN
G	3/8"	BMW
H	3/8"	GM
I	3/8"	VAG



53473

39,50€

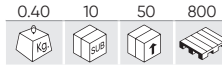

KIT EXTRATOR DE BUJÕES DE CÁRTER DE PLÁSTICO

A	3/8"	FORD
B	1/4"	VAG
C	1/4"	BMW
D	3/8"	PEUGEOT, CITROËN
E	1/4", 3/8"	



54802

20,00€

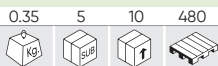

NEW

CHAVE PARA FILTRO DE ÓLEO – HYUNDAI / KIA

Peças	1
Medida do quadrado	1/2"
Marcas	HYUNDAI / KIA
Material	Acero/Steel
Diâmetro interior	80mm
Perfil	14 Caras/Sides
Peso	0,30Kg
Dimensões (CxLxA)	135x127x62mm



54587

205,00€

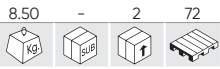

EXTRATOR PNEUMÁTICO DE INJETORES DE COMBUSTÍVEL COM ADAPTADORES E GARRAS DE EXTRACÇÃO

M20x1,0 10mm - M14x1,5 20mm	M14x1,5 9mm - M25x0,5 9mm
M18x0,75 10mm - M14x1,5 20mm	M14x1,5 9mm - M29x1,0 11mm
M17x1,0 10mm - M14x1,5 20mm	M14x1,5 9mm - M31x0,75 15mm
M8x1,25 14mm - M14x1,5 14mm	M14x1,5 8mm - M26x0,75 15mm
M8x1,00 14mm - M14x1,5 14mm	M18x1,5 18mm - M14x1,5 15mm
M10x1,5 14mm - M14x1,5 14mm	M22x1,5 15mm - M14x1,5 33mm
M14x1,5 9mm - M27x1,0 10mm	M20x1,5 18mm / M12x1,5 18mm - M14x1,5 15mm
M14x1,5 9mm - M27x1,0 10mm	M14x1,5 16mm
M14x1,5 9mm - M25x1,0 13mm	M14x1,5 13,5mm
M14x1,5 9mm - M27x0,75 10mm	M14x1,5 12mm



54768

80,00€

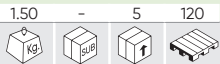

NEW

REMOVEDOR DE INJETORES PARA O GRUPO VAG

MARCAS	AUDI SEAT SKODA
FERRAMENTAS OEM	T10402
CÓDIGOS DE MOTOR	CAGA, CAGB, CAGC, CAHA, CAHB, CAYA, CAYB, CAYC, CAYD, CAYE, CBAA, CBAB, CBBD, CBDA, CBDB, CBDC, CDBA, CEGA, CFFA, CFFB, CFFD, CFFE, CFGB, CFGC, CFGD, CFHA, CFHB, CFHC, CFHD, CFHE, CFHF, CFJA, CFJB, CFWA, CGLA, CGLB, CGLC, CGLD, CGLE, CJAA, CJCA, CJCB, CJCC, CJCD, CKFB, CKFC, CKTB, CKTC, CKUB, CKUC, CLCA, CLCB, CLHA, CLHB, CLJA, CLLA, CLLB, CLNA, CMEA, CMFA, CMFB, CMGA, CMGB, CNEA, CNFA, CNFB, CNHA, CNHC, CRBB, CRBC, CRBD, CRKA, CRKB, CRLB, CRLC, CRLD, CRMB, CRUA, CRVA, CRVC, CSHA, CSLA, CSNA, CSUA, CSUB, CSUD, CSUE, CUSA, CUSB, CUTA, CUUA, CUUB, CUUD, CUUE, CUUF, CUVA, CUVB, CUVC, CUVD, CUVE, CUWA, CUXA, CVCA, CXMA, CXXA, CXXB, CYKA, CYKB, CYZA, CYZB, CZHA, DBBA, DBGA, DBGB, DBGC, DBKA, DCXA, DCYA, DCYB, DCZA, DDCA, DDCB, DDDA, DDYA, DDYB, DEJA, DEJB, DELA, DEUA, DEUB, DEUC, DFEA, DFEB, DFFA, DFGA, DFGB, DFGC, DFHA, DFLA, DFLD, DFSA, DFSB, DFSC, DFSD, DFSE, DFSF, DFTA, DFTB, DFTC, DGDA, DGMA, DGTA, DGTB, DGTC, DGTD, DGTÉ, DJGA, DLTA, DLUB, 1.2L, 1.4L, 1.6L, 2.0L TDI COMMON-RAIL ENGINES, 1.6L TDI CR DIESEL, 2.0L TDI



54186

199,00€



EXTRATOR PNEUMÁTICO PARA INJETORES

M20x1,0 10mm	M25x1,0 13mm
M10x1,5 14mm	M26x0,75 15mm
M14x1,5 15mm	M27x0,75 10mm
M14x1,5 33mm	M29x1,0 11mm
M16x1,5 18mm	M31x0,75 15mm
M17x1,0 10mm	M8x1,0 14mm
M18x0,75 10mm	M8x1,25 14mm
M18x1,5 18mm	M14x1,5 9mm
M22x1,5 15mm	M14x1,5 9mm
M25x0,5 9mm	

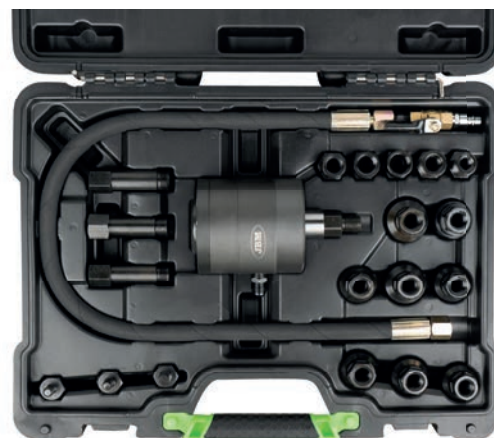

VIDEO TUTORIAL



REPOSIÇÕES DISPONÍVEIS

54345

15,00€

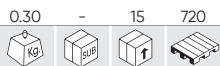

SPRAY DE GELO



Peças	1
Capacidade	400ml
Peso	0,30Kg
Dimensões (CxLxA)	200x60x70mm

16295

32,00€



CONJUNTO DE 3 ADAPTADORES PARA EXTRACTOR DE INJETORES (REF.54186)



Peças	3
Peso	1,55Kg
Dimensões (CxLxA)	160x130x40mm

54740

64,00€



EXTRACTOR DE INJETORES PARA FORD/VOLVO GTDI

Peças	6
Marcas	FORD, VOLVO
Material	Acero/Steel
Peso	1,75Kg
Dimensões (CxLxA)	650x55x103mm



51494

107,00€



KIT EXTRAÇÃO DE INJETORES



A	M12 x 1.75		M8 x 1.5
B	M14 x 1.5		M17 x 1.5
C	M14 x 1.5		M27 x 1.0
D	M14 x 1.5		M12 x 1.75
E	M14 x 1.5		M8 x 1.5
F	M14 x 1.5		M8 x 1.5
G	M14 x 1.5		
H			
I			

54566

179,00€



CONJUNTO DE EXTRACTOR MANUAL DE INJETORES



Peças	25
Marcas	BOSCH, CAT, CUMMINS, DENSO, DELPHI, SIEMENS
Material	S
Peso	7,95Kg
Dimensões (CxLxA)	380x120x270mm

52858

298,00€

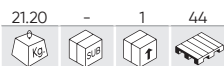

KIT DE EXTRAÇÃO DE INJECTORES

Martelos	
1,6Kg (160mm)	
2,7Kg (460mm)	
5,1Kg (600mm)	
Puxando a aderência com a abertura da forquilha	
13,7x18mm (105mm)	
12,7x19mm (130mm)	
Vasos de fenda (6pt)	1/2" - 25, 27, 28, 29, 30mm (100mm)
Adaptador com rosca externa	M27x1.0 (x3), M25x1.0
Adaptador com rosca interna	M27x1.0 (x3)
Eixo extrator injector	M17x1.0
Adaptador de martelo deslizante para extrator interno, externo e garra	

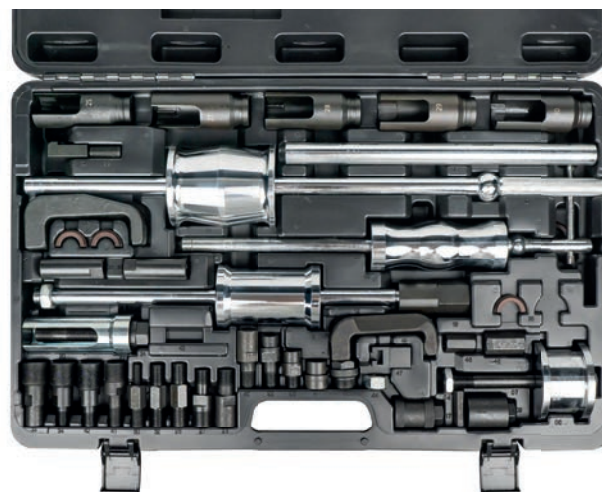

54750

98,00€

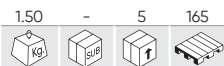

EXTRATOR DE INJECTORES PARA DIESEL ECOBLUE 2.0L

Peças	14
Marcas	FORD
Material	Acero/Steel
Peso	1,50Kg
Dimensões (CxLxA)	350x310x54mm



54892

112,50€

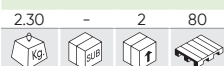

NEW

EXTRATOR DE INJECTORES COMMON RAIL PARA MOTORES BMW / MINI B38 B48



Peças	6
Marcas	BMW/MINI
Material	Metal/Steel
Peso	2.3Kg
Dimensões (CxLxA)	380x350x80mm

54598

33,00€



EXTRATOR DE INJETOR PARA MOTOR A DIESEL FORD 2.0L ECOBLUE



Peças	4
Marcas	FORD
Material	CSTL
Peso	8,00Kg
Dimensões (CxLxA)	370x120x280mm

54220

213,00€



KIT DE FERRAMENTAS PARA INSTALAÇÃO E DESMONTAGEM DE INJETORES DE COMBUSTÍVEL PARA BMW MERCEDES



Peças	23
Marcas	BMW, MERCEDES BENZ
Peso	4,40Kg
Dimensões (CxLxA)	500x360x97mm

53069

98,00€



KIT DE EXTRAÇÃO DE INJETORES DIESEL PARA CITROËN, PEUGEOT, FIAT



Peças	9
Marcas	CITROËN, PEUGEOT, FIAT
Peso	3,44Kg
Dimensões (CxLxA)	300x220x65mm

52629

99,00€

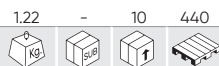

KIT DE EXTRAÇÃO PARA INJETORES MÉRCEDES



Peças	3
Marcas	MERCEDES BENZ
Material	CrV
Peso	1,22Kg
Dimensões (CxLxA)	210x145x50mm

53501

24,00€

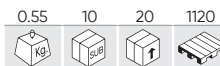

EXTRATOR DE BOMBA DE INJEÇÃO DIESEL BMW



Marcas	BMW
Peso	0,55Kg

53009

42,00€

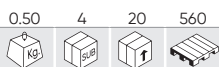

EXTRATOR DE TUBO DE INJEÇÃO DIESEL



Peças	3
Medida do quadrado	1/2"
Medida	M14, M17, M19
Peso	0,50Kg

52757

17,20€

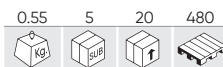

EXTRATOR UNIVERSAL DE AFORADORES



Diâmetro	75-160mm
Medida	24mm
Peso	0,55Kg
Dimensões (CxLxA)	345x210x90mm

53522

24,00€

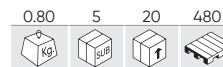

EXTRATOR DE ANILHAS DE INJETORES



Diâmetro	4,5-15mm
Comprimento	350mm
Peso	0,80Kg

53096

28,80€

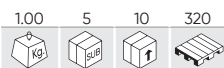

CHAVE PARA TAMPA DE AFORADORES



Material	Acero/Steel
Diámetro	89-170mm
Medida	15mm
Peso	1,00Kg
Dimensões (CxLxA)	150x150x100mm

55092

28,00€

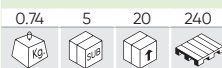

NEW

CHAVE PARA PORCA DA BOMBA DE COMBUSTÍVEL BMW / MINI



Peças	1
Medida do quadrado	1/2"
Marcas	BMW/MINI
Material	Acero/Steel
Dimensões (CxLxA)	0,80Kg
Peso	158x158x100mm

53650

47,00€

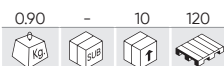

KIT LIMPADOR DE INJETORES DE VEDAÇÃO



REPOSIÇÕES DISPONÍVEIS

x3	Escovas de aço
x2	Escovas de silicone-nylon
x1	Extensor
x6	Tampões de fechamento
x1	Haste para inserção dos bujões de fechamento
x1	Escova de aço para limpeza da cabeça do cilindro



51493

68,00€

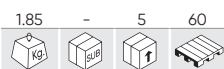

MEDIDOR E COMPROVADOR DE SISTEMA DE INJEÇÃO



REPOSIÇÕES DISPONÍVEIS



Peças	31
Marcas	BOSCH, SIEMENS, DENSO, DELPHI
Material	PT, Cu-Zn
Dimensões (CxLxA)	410x325x87mm
Peso	1,85Kg

54847

41,50€

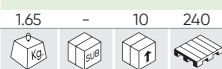

NEW

EXTRACTOR DE VEDANTES DE INJECTORES COM CABEÇA INTERCAMBIÁVEL



Peças	5
Material	CrV, Acero al carbono/Carbon steel
Peso	1,55Kg
Dimensões (CxLxA)	320x135x49mm

54392

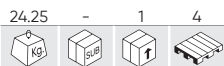

LIMPADOR E TESTADOR DE INJETORES GDI / EFI

Tensão de funcionamento	220V (50/60Hz)
Potência dos ultra-sons	60W
Pressão do trabalho	0,1-10BAR
Pressão de ar máxima	5-8BAR
Temperatura de trabalho	-10~40°C
Peso	18,50Kg
Dimensões (CxLxA)	490x545x570mm



VÍDEO TUTORIAL



1.855,00€

54826



NEW

KIT DE VERIFICAÇÃO DA PRESSÃO DO TURBO

Peças	17
Adaptadores	38/31, 46/51, 55/60, 65/70, 75/80, 85/90, 95/100, 105/110mm
Pressão máxima	80PSI
Peso	7,00Kg
Dimensões (CxLxA)	580x480x130mm



162,00€

54391



TESTE PARA BICOS INJETORES DE DIESEL



Gama de medição	0-60MPa
Conectores	M12(x1), M14(x2)
Peso	3,05Kg
Dimensões (CxLxA)	460x270x200mm

221,00€

52488



MEDIDOR DE COMPRESSÃO GASOLINA

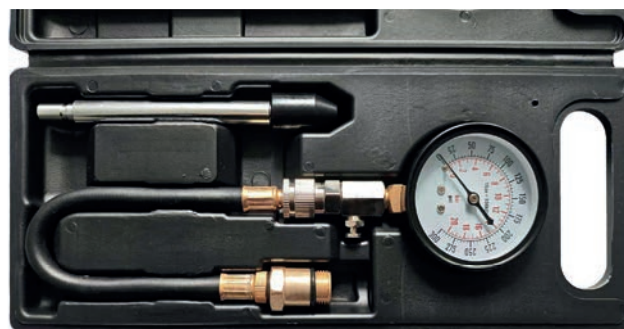

Peças	2
Pressão do trabalho	0-21BAR
Peso	0,65Kg
Dimensões (CxLxA)	325x135x50mm

28,00€

53997

48,00€

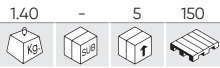

KIT DE TEST DE PRESSÃO - GASOLINA

Peças	10
Comprimento da mangueira de alta pressão	1100mm
Manômetro	0-10BAR
Peso	1,40Kg
Dimensões (CxLxA)	320x260x60mm



54373

395,00€

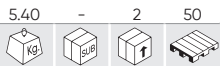

MANÔMETRO COMMON RAIL DE ALTA PRESSÃO



REPOSIÇÕES DISPONÍVEIS

Peças	32
Marcas	Multimarca/Multi-brand
Medidas	14, 17, 19mm
Adaptadores	M12x1,25, M14x1,25, M12x1,5, M14x1,5
Pressão do trabalho	0-1300BAR
Peso	5,40Kg
Dimensões (CxLxA)	448x115x302mm



52599

230,00€

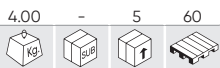

MEDIDOR DE COMPRESSOR PARA CIRCUITOS DE GASOLINA

Peças	39
Marcas	Multimarca/Multi-brand
Pressão do trabalho	0-10BAR
Peso	4,00Kg
Dimensões (CxLxA)	410x100x290mm



54312

194,00€



KIT DE TESTE DE COMPRESSÃO - DIESEL

Peças	43
Marcas	Multimarca/Multi-brand
Medidas	10,12,14,18mm
Adaptadores	M22, M20, M24
Pressão do trabalho	0-48,3BAR
Peso	4,50Kg
Dimensões (CxLxA)	430x370x105mm



53490

275,00€

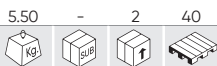

COMPROVADOR DE PRESSÃO PARA DIESEL E GASOLINA

Peças	44
Marcas	Multimarca/Multi-brand
Medidas	Bujia/Spark plug: 10,12,14,18mm
Pressão do trabalho	0-42BAR
Peso	5,50Kg
Dimensões (CxLxA)	500x360x100mm



52489

58,00€



MEDIDOR DE COMPRESSÃO DIESEL



Peças	19
Pressão do trabalho	0-69BAR
Peso	2,15Kg
Dimensões (CxLxA)	395x317x81mm

52685

92,00€

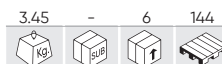

MEDIDOR DE COMPRESSÃO DIESEL PARA CAMIÓN



Peças	18
Pressão do trabalho	0-70BAR
Peso	3,45Kg
Dimensões (CxLxA)	400x320x80mm

52813

79,00€



KIT DE CHAVES DE INJETORES 17 PCS



Peças	17
Marcas	MultiMarca/Multi-brand
Material	35CrMo
Peso	2,23Kg
Dimensões (CxLxA)	307x225x65mm

52273

44,00€



KIT DE CHAVES DE INJETORES



Peças	8
Marcas	Multimarca/Multi-brand
Material	35CrMo
Peso	1,40Kg
Dimensões (CxLxA)	287x205x63mm

55013 **84,00€**

2.66 - 3 72 **NEW**

KIT DE DETECÇÃO DE FUGAS PARA SISTEMAS DE TURBOALIMENTAÇÃO COM MANÓMETRO

Peças	9
Pressão do trabalho	0-86 PSI (0-6 BAR)
Peso	4,00Kg
Dimensões (CxLxA)	380x300x70mm



53489 **68,00€**

0.70 5 10 260

COMPROVADOR DE PRESSÃO DO TURBO



Peças	2
Pressão do trabalho	0,75-3BAR
Comprimento da mangueira de alta pressão	2m
Peso	0,70Kg
Dimensões (CxLxA)	260x170x60mm

53426 **39,80€**

0.90 4 16 224

PROVADOR DE PRESSÃO E VÁCUO



Peças	9
Nível de vácuo	0-0,7Kg/cm2 (0-10PSIG) / 0-28inHg (0-70cmHg)
Peso	0,90Kg
Dimensões (CxLxA)	198x150x200mm

54590 **108,00€**

1.43 - 5 75

CONJUNTO PARA PURGAR SISTEMAS DE COMBUSTÍVEL A DIESEL



Peças	12
Marcas	Multimarca/Multi-brand
Compatível com	Inyectors Diesel/Diesel injectors
Peso	1,43Kg
Dimensões (CxLxA)	326x70x414mm

52789 **15,20€**

0.15 6 24 192

BOMBA MANUAL EXTRAÇÃO GASOIL



Comprimento da mangueira de alimentação	900mm
Comprimento da mangueira de aspiração	900mm
Material	0,15Kg
Peso	PVC

52801 **26,00€**

0.10 5 50 600

BOMBA INJETORA DIESEL



Marcas	Multimarca/Multi-brand
Compatível com	Inyectors Diesel/Diesel injectors
Peso	0,10Kg
Comprimento	340mm

52821

29,50€

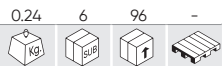

CHAVE DUPLA ABERTA PARA INJECTORES



Material	CrV
Compatível com	Inyectors Diesel/Diesel injectors
Peso	0,24Kg
Comprimento	290mm

53330

38,50€



SET DE CHAVES PARA BOMBA INJETORA



Peças	5
Diâmetro	1/2", 1/4"
Peso	0,75Kg
Dimensões (CxLxA)	180x130x55mm

PUNÇÕES

Permitem a aplicação de marcação digital ou alfabética em qualquer superfície de metal por método de indentação ou impacto. A área de trabalho arredondada evita rachaduras ou fraturas na superfície tratada.

REF.	DESCRIÇÃO					€
52422	PUNÇÕES ALFABÉTICOS E NUMÉRICOS 5MM	0.82	4	16	540	24,70€
53119	PUNÇÕES ALFABÉTICOS E NUMÉRICOS 8MM	1.94	3	6	504	55,00€
52882	PUNÇÕES DE NÚMEROS 6MM	0.30	10	60	1500	14,00€



52422



53119



52882

51120

41,00€



GRAMPO DE VÁLVULAS



Peças	6
Adaptadores	16, 19, 23, 25, 30mm
Peso	1,50Kg
Dimensões (CxLxA)	450x340x22mm

52693

26,50€

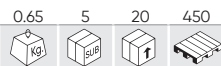

COMPRESSOR DE MOLA PARA VÁLVULAS



Compatível com	OHV, OHC, CHV
Peso	0,65Kg
Dimensões (CxLxA)	390x110x30mm

52734

53,00€

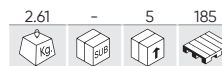

COMPRESSOR DE MOLA DE VÁLVULAS 35-142MM



Abertura	35-142mm
Peso	2,50Kg
Dimensões (CxLxA)	400x300x30mm

54772 55,00€

1.10 5 10 200 NEW

KIT DE REMOÇÃO E INSTALAÇÃO DE FECHOS DE VÁLVULAS



Peças	2
Magnetizado	Si/Yes
Peso	1,08Kg
Dimensões (CxLxA)	176x61x51mm

54525 77,00€

1.92 - 5 120

POLIDOR DE CILINDROS DO MOTOR



Peças	7
Medidas	2" - 7", 1-1/4" - 3-1/2", 1" - 2-3/4", 3/4" - 2"
Peso	1,50Kg

POLIDORA DE CILINDROS

REF.	DESCRIÇÃO					€
52591	POLIDORA DE CILINDROS - 2 BRAÇOS 1 - 1/8" (19-55MM)	0.10	12	72	1728	12,00€
52592	POLIDORA DE CILINDROS - 3 BRAÇOS 2" (35-85MM)	0.20	-	20	480	22,00€
52593	POLIDORA DE CILINDROS - 3 BRAÇOS 4" (55-170MM)	0.47	6	36	540	34,00€

52591



REPOSIÇÕES DISPONÍVEIS



52592



REPOSIÇÕES DISPONÍVEIS



52593



REPOSIÇÕES DISPONÍVEIS



ALICATES PARA ANÉIS DE PISTÃO

REF.	DESCRIÇÃO					€
54273	ALICATES PARA ANÉIS DE PISTÃO 40-100MM	0.30	6	30	-	12,00€
54274	ALICATES PARA ANÉIS DE PISTÃO 80-120MM	0.35	6	30	-	13,00€
54275	ALICATES PARA ANÉIS DE PISTÃO 100-160MM	0.40	6	30	-	15,50€



54273



54274



54275

53251

94,00€

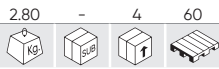

KIT DE FERRAMENTAS PARA AROS DE PISTÃO



REPOSIÇÕES DISPONÍVEIS



A	x1	H:3" Ø 53 - 125mm (75mm)	E	x1	1.2 - 5.5mm
B	x1	H:4" Ø 90 - 175mm (90mm)	F	x1	PH2, SL5.5
C	x1	H:6" Ø 90 - 175mm (100mm)	G	x2	6 in 1
D	x1	50 - 100mm	H	x3	6mm

52696

12,00€

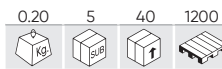

COMPRESSOR AROS PISTÃO 3"



52697

16,00€

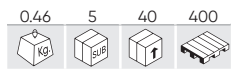

COMPRESSOR AROS PISTÃO 6"



54318

115,00€

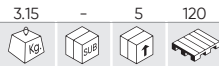

REBITADOR DE CORRENTE DE DISTRIBUIÇÃO

MARCAS	CHRYSLER JEEP MERCEDES
FERRAMENTAS OEM	103589016300, 112589026300, 602589003900, 602589023300, 602589046301

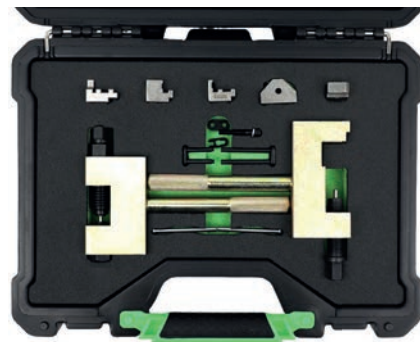

53662

89,00€

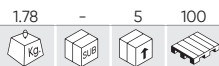

COMPROVADOR DE FUGA PARA JUNTAS DE CILINDROS



VÍDEO TUTORIAL



REPOSIÇÕES DISPONÍVEIS



Peças	9
Capacidade	200-250ml
Adaptadores	Pequeno/Small, Mediano/Medium, Grande/Large
Marcas	Multimarca/Multi-brand
Peso	1,78Kg
Dimensões (CxLxA)	400x260x75mm

54347

49,00€



VERIFICADOR DE FUGAS DE CILINDROS

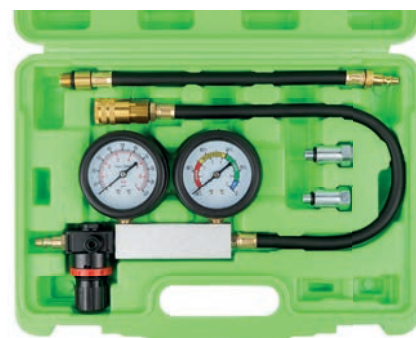

Peças	4
Adaptadores	M10x1.0, M12x25, M14x1.2
Entrada de ar	1/4"
Pressão do trabalho	6,5BAR
Peso	2,00Kg
Dimensões (CxLxA)	340x80x240mm

52754

54,00€

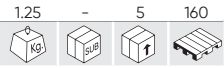

MEDIDOR DE PRESSÃO DE ÓLEO



Peças	12
Gama de medição	1-10BAR
Peso	1,25Kg
Dimensões (CxLxA)	330x260x60mm

54956

98,00€

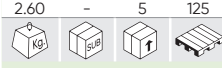

NEW

KIT TESTADOR DE PRESSÃO DE ÓLEO

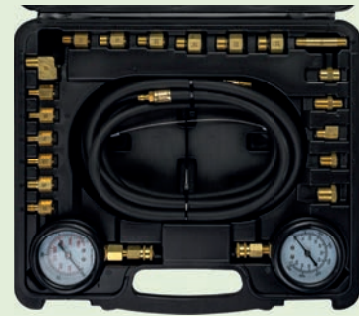

Peças	23
Pressão máxima	6,90-27,58BAR
Peso	3,00Kg
Dimensões (CxLxA)	340x220x90mm

52076

111,00€



KIT PARA REPARAR ROSCAS DE VELAS DIESEL

x2	Instalação de casquilho	x1	Barra de instalação de casquilho
x1	Pega para varilha	x1	M14x1.25
x5	M8x1.0	x1	M12x1.25
x5	M10x1.0	x1	M12x1.0
x5	M10x1.25	x1	M10x1.25
x5	M12x1.25	x1	M10x1.0
x3	Bujão c/ extremidades s/rosc	x1	M8x1.0



REPOSIÇÕES DISPONÍVEIS

52815

110,00€

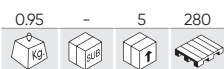

KIT EXTRATOR DE VELAS INCANDESCENTES



x2	M8x1.0	x1	ø2.5x120mmL
x2	M10x1.0	x1	ø3.3x140mmL
x2	M10x1.25	x1	M3x0.5x100mmL
x1	M8x1.0	x1	M4x0.7x100mmL
x1	M10x1.0	x1	M3x0.5x180mmL
x1	M10x1.25	x2	M4x0.7x180mmL
x1	M8x1.0	x3	
x1	M10x1.0		
x1	M10x1.25		

52305

106,00€



KIT REPARADOR DE VELAS DE AQUECIMENTO



x2	M8x1.0	x1	ø2.5x120mmL
x2	M10x1.0	x1	ø3.3x140mmL
x2	M10x1.25	x1	M3x0.5x100mmL
x1	M8x1.0	x1	M4x0.7x100mmL
x1	M10x1.0	x1	M3x0.5x180mmL
x1	M10x1.25	x2	M4x0.7x180mmL
x1	M10x1.25		

54874

13,00€

0.20 10 40 720



NEW

UNIDADE MECATRÓNICA DE EXTRACÇÃO DSG 7 VAG



Peças	1
Marcas	VAG
Material	Acero/Steel
Peso	0,20Kg
Dimensões (CxLxA)	240x95x20mm

54800

17,50€

0.60 10 20 560



NEW

CHAVE PARA SEGURAR A POLIA DO VIRABREQUIM NOS MOTORES HONDA E ACURA - 1/2"



Peças	1
Material	Cr-Mo
Diâmetro	50mm ~ 1/2"
Peso	1,00Kg
Dimensões (CxLxA)	120x70x53mm

54845

10,00€

0.59 12 72 864



NEW

FERRAMENTA DE INSTALAÇÃO DA CORREIA ELÁSTICA PARA PSA



Peças	1
Marcas	PSA
Peso	0,07Kg

54971

18,50€

0.37 10 20 2500



NEW

FERRAMENTA DE BLOQUEIO DO VOLANTE DO MOTOR BMW N20/N26



Peças	1
Peso	0,40Kg
Dimensões (CxLxA)	110x42x40mm

51927

25,00€

0.65 - 20 800



DESMONTADOR E TENSOR DE CORREIAS EN POLI-V



54890

23,00€

0.18 10 50 1800



NEW

CONJUNTO DE ADAPTADORES PARA TENSORES DE CORREIA

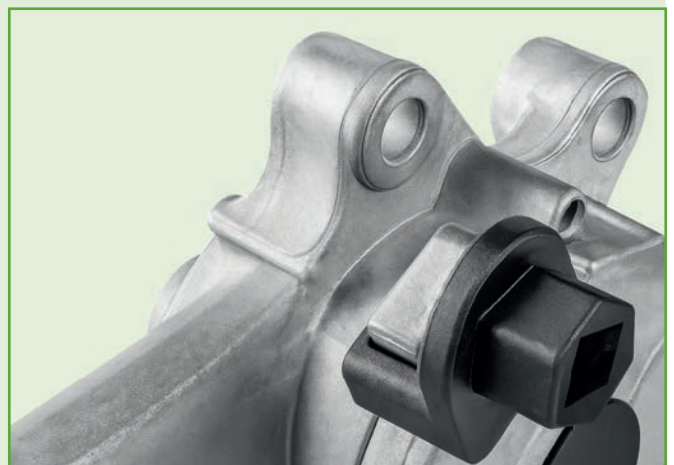
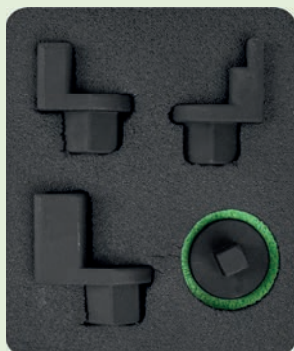

Peças	4
Peso	0,18Kg
Dimensões (CxLxA)	85x75x65mm

53637 85,00€

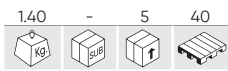

ORGANIZADOR PARA COMPONENTES DO MOTOR ESPECIAL PARA PEÇAS DE CABEÇOTES



Peças	1
Peso	1,40Kg
Dimensões (CxLxA)	450x400x104mm

52850 7,80€

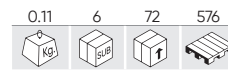

2PCS FERRAMENTA PARA RODAR VÁLVULAS



Peças	2
Material	Madera/Wood, Goma/Rubber
Diâmetro	3,49-2,86mm/1,59-2,06mm
Peso	0,11Kg

52690 56,00€

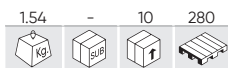

ALAVANCA PARA AFROUXAR CORREIAS



A	x4	13, 15, 16, 18mm
B	x3	13, 14, 15mm
C	x1	1/2" 230mm
D	x1	3/8" 585mm

52832 75,00€

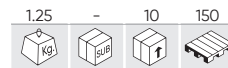

JOGO DE CHAVES CURVADAS PARA EXTRAÇÃO DE CORREIAS 12 CANTOS CABEÇA INTERCAMBIÁVEL



A	x8	12, 13, 14, 15, 16, 17, 18, 19mm
B	x1	450mm
C	x1	50mm

54951 159,00€

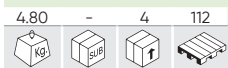

NEW

KIT COMPRESSOR DE MOLAS DE VÁLVULAS MULTIAIR

Peças	17
Peso	4,60Kg
Dimensões (CxLxA)	490x150x90mm



53572 348,00€

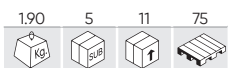

FERRAMENTA PNEUMÁTICA PARA POLIMENTO DE VÁLVULAS - PERCUSSÃO E ROTAÇÃO



REPOSIÇÕES DISPONÍVEIS



Peças	12
RPM (rotações por minuto)	800
Entrada de ar	1/4"
Consumo real de ar	1,80CFM (51L/min)
Peso	1,90Kg
Dimensões (CxLxA)	283x87x70mm

54033 49,00€

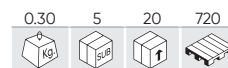

FERRAMENTA PARA BERBEQUIM - RODA VÁLVULAS



REPOSIÇÕES DISPONÍVEIS



Peças	6
Diâmetro	16, 20, 30, 35, 40mm
RPM (rotações por minuto)	1250
Peso	0,30Kg
Comprimento	128mm

192,00€

53249



ESTETOSCÓPIO ELECTRÔNICO

Peças	11
Comprimento da sonda de áudio	140mm
Bateria	9V
Quantidade de sensores	6
Adequado para conectores	3,5mm
Comprimento ajustável do microfone	210mm
Comprimento do cabo do sensor	4,8m
Peso	2,65Kg
Dimensões (CxLxA)	410x360x110mm



51347

9,90€

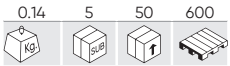

ESTETOSCÓPIO



INFORMAÇÕES ADICIONAIS

52190

8,00€

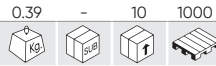

CHAVE DE EMBREAGEM ESPECIAL FIAT

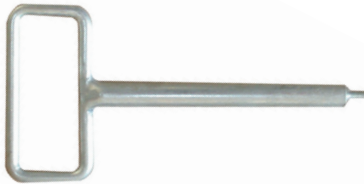

INFORMAÇÕES ADICIONAIS

52495

14,50€



CENTRALIZADOR EMBREAGENS UNIVERSAL (PLÁSTICO)



INFORMAÇÕES ADICIONAIS

53410

92,00€

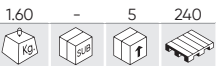

CENTRALIZADOR DE EMBREAGEM SAC



Peças	11
Marcas	Multi-marca/Multi-brand
Peso	1,60Kg
Dimensões (CxLxA)	275x60x215mm

53057

149,00€

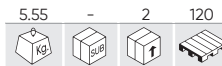

KIT DE REPARAÇÃO DO EMBREAGEM DUPLA FACE PARA LA TRANSMISSÃO DSG DE VAG



Peças	5
Compatível com	GOLF (2004), GOLF PLUS (2005), AUDI A3 (2004), TOUAREG (2003)
Peso	5,55Kg
Dimensões (CxLxA)	315x200x110mm

53001

242,00€

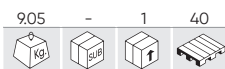

KIT CENTRADOR DE EMBREAGEM SAC

- x1 Tensor de Embreagem
- x1 Centralizador de 3 braços
- x1 Ferramenta para repor parâmetros de origem
- x1 Jogo de pinos centralizadores
- x1 Centralizador de 4 braços

VW, AUDI, BMW, MERCEDES, VOLVO, RENAULT, OPEL



54828

205,00€

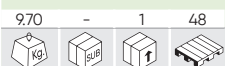

NEW

KIT EXTRATOR DE EMBREAGEM DUPLA PARA FORD

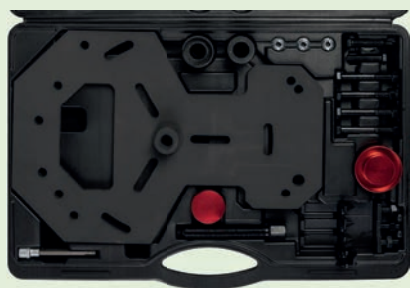

Peças	12
Marcas	FORD
Material	Acero al carbono/Carbon Steel
Peso	9,70Kg
Dimensões (CxLxA)	530x355x105mm

54824

129,00€

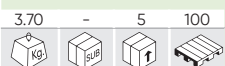

NEW

CENTRALIZADOR DE EMBREAGEM PARA CAMINHÕES (36-52 MM)



Peças	7
Faixa	36-52mm
Material	Acero al carbono/Carbon steel
Peso	3,70Kg
Dimensões (CxLxA)	350x270x65mm

52963

49,00€

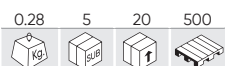

REFRATÔMETRO UNIVERSAL PARA GLICOS, ANTICONGELANTES, UREIA E LÍQUIDOS DE BATERIA



- Etileno glicol: -50°C ~ -0°C.
- Propileno glicol: -50°C ~ -0°C.
- Fluido de limpeza: -40°C ~ -0°C.
- UREA AUS32: - 30% ~ 35%.
- Fluido de bateria: - 1.100 - 1.400 sg/l.

Peças	4
Peso	0,28Kg
Dimensões (CxLxA)	205x85x55mm

53477

39,50€



KIT DE 8 PINÇAS PARA A DESCONEXÃO DE MANGUEIRAS



Peças	8
Diâmetro	8, 10, 13mm
Peso	0,80Kg
Dimensões (CxLxA)	265x210x60mm

52066

12,00€

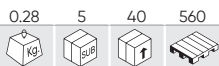

KIT DE ALICATES PARA MANGUEIRAS FLEXIVEIS

A	x1	0-70mm
B	x1	0-35mm
C	x1	0-20mm



53395

16,00€

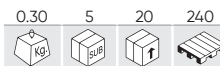

KIT DE ALICATES PARA MANGUEIRAS FLEXIVEIS

A	x1	0 - 35mm
B	x1	0 - 20mm
C	x1	0 - 13mm

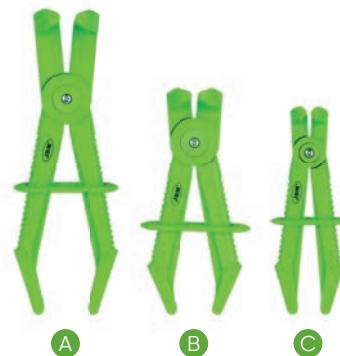

54591

58,00€

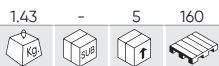

DISPOSITIVO DE TESTE DA BOMBA DA ÁGUA

Peças	8
Peso	1,43Kg
Dimensões (CxLxA)	350x25x65mm



52687

168,00€

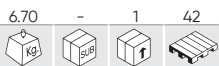

COMPROVADOR DE VAZAMENTO DE PRESSÃO PARA SISTEMA DE REFRIGERAÇÃO

1	Bomba de pressão com válvula de descarga
2A	Conector 1: acoplador para os cabeçães No.3(R123) e No.4 (R124)
2B	Conector 2: acoplador para os cabeçães No. 3(R123) y No. 5(R125)
3	Mercedes (W123, W126, W124, W201), GM(Buick), Jeep
4	Peugeot, Subaru, Chrysler, Acura, GM, Mitsubishi, Nissan, Mazda, Toyota, Infiniti, GEO, Suzuki, Isuzu, Mercedes
5	Honda, Toyota, Suzuki, Mitsubishi, Chrysler, Acura
6	Mercedes Benz (ML, W163, W164), GM (Achiva, Skylark, Grand Am 1992~2002)
7	Volvo, Saab, Sterling, Citroën, Renault, Fiat, Alfa, Jeep
8	VW(Vento, T4, Passat-1996, Golf, Beetle, Sharan)
9	Audi(A4, A5, A6), BMW 345, VW (Passat - 1997~2002), Porsche(Cayenne)
10	BMW (E46, E36, E34, E39, E38, E32, E90)
11	Audi, VW
12	Internacional, Land Rover, Jaguar
13	Mercedes (C, E, S, W140, W220, W124, W210, W211, W215, W216, W221, R230)
14	Ford Focus
15	Mazda(M3)
16	Mercedes classe A (W168)
17	BMW E60, E63, E64, E65
18	VW SHARAN 1.8T 2.8
19	TOYOTA-RAV4, PREVIA Adaptador universal de goma para purga e enchimento adores
20	SAAB
21	LAND ROVER
22	Kia
23	Hunday



54957 99,00€

2.32 - 10 80

NEW

FERRAMENTA DE ENCHIMENTO DO SISTEMA DE ARREFECIMENTO



Peças	9
Pressão máxima	6.2 BAR
Comprimento da mangueira	1.3M
Peso	0,60Kg
Dimensões (CxLxA)	240x217x120mm

54861 159,00€

1.65 - 2 40

NEW

TESTADOR DO SISTEMA DE ARREFECIMENTO DE CAMIÕES



Peças	9
Marcas	DAF-IVECO, MAN-RENAULT, VOLVO-SCANIA
Peso	1,65Kg
Dimensões (CxLxA)	450x330x120mm

55007 58,00€

1.44 - 10 80

NEW

KIT DE PURGA E ENCHIMENTO A VÁCUO PARA LÍQUIDO DE ARREFECIMENTO



Peças	4
Peso	1,50Kg
Dimensões (CxLxA)	380x320x70mm

54139 147,00€

3.15 - 5 80

TESTADOR UNIVERSAL DE PRESSÃO PARA SISTEMAS DE REFRIGERAÇÃO



Peças	5
Pressão do trabalho	0-2,5BAR
Peso	3,15Kg
Dimensões (CxLxA)	445x90x290mm

53453 7,00€

0.10 24 96 384

TESTADOR DE ANTICONGELANTE



Peças	1
Gama de medição	43/125°C
Peso	0,10Kg



54565

2.268,00€

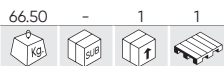

MÁQUINA DE MUDANÇA DE LÍQUIDO DE REFRIGERAÇÃO

Faixa de pressurização do tanque novo	0,85-1,5BAR
Capacidade máxima de vácuo	-20InHg
Volume recomendado de líquido de refrigeração novo	12L
Comprimento da mangueira de aspiração	2,7m
Pressão do trabalho	5-10BAR
Peso	43,00Kg
Dimensões (CxLxA)	630x480x1340mm



VÍDEO TUTORIAL



REPOSIÇÕES DISPONÍVEIS

16309

149,00€

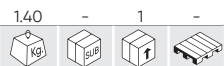

KIT DE 2 TUBOS DE ALTA E BAIXA PRESSÃO COM 5 METROS DE COMPRIMENTO



53499

29,00€

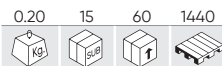

ADAPTADOR PARA CARGA DE GÁS 1234YF (ALTA)



53500

29,00€

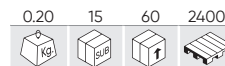

ADAPTADOR PARA CARGA DE GÁS 1234YF (BAIXA)



53456

98,00€



CONJUNTO DE VERIFICAÇÃO, ENCHIMENTO E ESVAZIAMENTO PARA SISTEMAS DE AR-CONDICIONADO - COMPATÍVEL COM

Peças	9
Rosca de união	7/16x20UNF
Pressão do trabalho	0-24, 0-34BAR
Comprimento da mangueira de alta capacidade	1550mm
Peso	2,90Kg
Dimensões (CxLxA)	305x305x95mm



REPOSIÇÕES DISPONÍVEIS

55085

4.780,00€

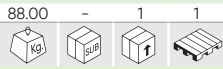

NEW

ESTAÇÃO DE CARGA PARA AR CONDICIONADO

Potência	700W
Potência do compressor	3-8HP
Percentagem de recuperação	95%
Tela	7" Táctil / 7" Touchscreen
Velocidade de carga do refrigerante	2Kg/min (máx.)
Capacidade da bomba de vácuo	60L/min
Capacidade do tanque de refrigerante	10L
Capacidade de óleo novo	250ml
Capacidade de óleo usado	400ml
Temperatura de trabalho	0-50°C
Pressão máxima	20BAR
Alimentação	220V+-10%, 50/60Hz
Tipo de refrigerante	R134A/R1234YF
Peso	88,00Kg
Dimensões (CxLxA)	660x583x1058mm



REPOSIÇÕES DISPONÍVEIS

53539

69,00€

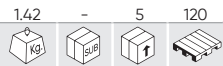

KIT DETECÇÃO FUGA AA/CC

- x1 Lâmpada UV 100Lm
- x1 Óculos de visão UV
- x1 Seringa inserção líquido
- x1 Adaptador rápido
- x1 Adaptador de extensão
- x1 Pila recargable
- x1 Carregador



REPOSIÇÕES DISPONÍVEIS

16316

18,50€

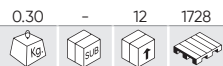

ÓLEO UNIVERSAL PAG PARA AR CONDICIONADO 250ML

Capacidade	250ml
Temperatura de trabalho	-30/50°C
Peso	0,30Kg
Dimensões (CxLxA)	50x50x160mm



12977

36,50€



LÍQUIDO DETECÇÃO FUGA SISTEMA AACC 250ML

Capacidade	250ml
Peso	0,33Kg
Dimensões (CxLxA)	175x100x55mm



54523

26,50€

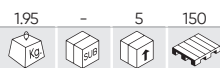

KIT PARA REMOÇÃO DA EMBREAGEM DO COMPRESSOR DO A/C

Peças	12
Peso	1,95Kg
Dimensões (CxLxA)	310x250x55mm



54536

152,00€



ENDOSCÓPIO PARA LIMPEZA DE AR CONDICIONADO

Peças	5
Tela	4,3" TFT LCD
Alimentação	Bateria/Battery 18650
Peso	1,65Kg
Dimensões (CxLxA)	410x295x75mm



VIDEO TUTORIAL

53459

66,00€

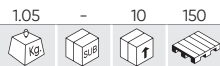

KIT PARA A DESCONEXÃO DO AR CONDICIONADO

Diâmetro das braçadeiras	
x6	8mm (5/16"), 9,5mm (3/8"), 13mm (1/2"), 16mm (5/8"), 19mm (3/4"), 22mm (7/8")
Diâmetro do bloqueador	
x4	9,5 mm (3/8"), 16mm (5/8"), 13mm (1/2"), 19mm (3/4")



53599

31,00€

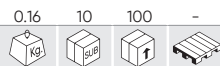

KIT DE VÁLVULAS PARA O AR CONDICIONADO

	PCS		PCS
5x19mm R12	50	7x20mm R134A	10
5x19mm R12	30	6x22mm	5
5x19mm	30	8x22mm	1
6x19mm	3	9x22mm	4
6x26mm	1		



50807

38,00€

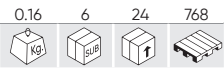

KIT DE O'RINGS PARA AACC

	PCS		PCS		PCS
5.29x1.78	20	8.80x1.90	20	13.95x2.62	10
6.07x1.78	20	10.82x1.78	15	14.0x2.0	10
6.8x1.9	20	10.77x2.62	15	15.0x2.0	10
7.65x1.78	20	11.0x2.0	15	17.0x2.0	10
7.80x1.90	20	12.0x2.0	15	17.17x1.78	10
8.0x2.0	20	13.9x1.80	10	17.04x3.53	10



CHAVE PONTA 1/2" XZN INVIOLÁVEL

REF.									€	
12029	CrV	1 PCS		1/2"	M16x58mm	0.17	5	100	1500	5,50€
12030	CrV	1 PCS		1/2"	M16x100mm	0.25	8	80	-	7,10€

12029



12030



54069

31,00€

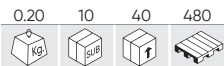

KIT DE FERRAMENTAS DE LIMPEZA DE BUCHAS, 14 PÇS



Peças	14
Adaptadores	8mm
Peso	0,20Kg

54749

54,00€



KIT DE LIMPEZA DE PERNOS E CUBOS



REPOSIÇÕES DISPONÍVEIS



Peças	7
Adaptadores	50x12, 50x13, 50x14, 60x16, 60x22, 60x28mm
Diâmetro	1/2"
Peso	0,54Kg

54384

35,00€

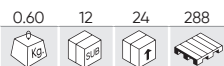

LIMPADOR DE CUBOS DE RODA

Peças	2
Diâmetro exterior	150mm
Diâmetro interior	90mm
Velocidade máxima de varredura	1500RPM
Diâmetro do eixo	1/2"
Peso	0,60Kg



REPOSIÇÕES DISPONÍVEIS



51364

26,00€

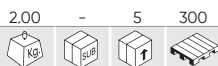

EXTRATOR DE JUNTAS HOMOCINÉTICAS



Largura	45mm
Comprimento máximo	240mm
Comprimento mínimo	140mm
Peso	2,00Kg

54894

62,00€



NEW

EXTRATOR DE JUNTAS HOMOCINÉTICAS PARA SUV - 4 PEÇAS

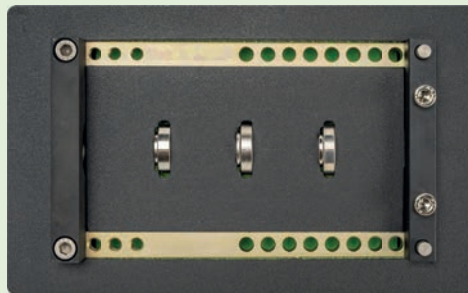

Peças	4
Peso	3,60Kg
Dimensões (CxLxA)	281x60x162mm

52829

19,00€



FERRAMENTA P/MONTAR FOLAS DE TRANSMISSÕES



Diâmetro exterior	100mm
Diâmetro interior	95mm
Peso	0,45Kg
Comprimento	410mm

51121

27,30€



KIT DE COMPRESSOR DE MOLAS



Peças	2
Capacidade	1T
Abertura	270mm
Peso	1,80Kg

52639

123,00€



KIT PARA BRAZOS DIREÇÃO



	x3	Ø 30-35, 35-40, 40-45mm
	x1	1/2"
	x1	3mm

51902

84,00€

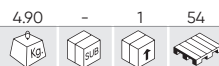

ALAVANCA DE EXTRAÇÃO DE RÓTULAS DE SUSPENSÃO COM ARTICULAÇÃO ESFÉRICA



REPOSIÇÕES DISPONÍVEIS

Comprimento	1180mm
Tubo	35mm
Peso	4,90Kg
Dimensões (CxLxA)	1118x330x60mm

54764 298,00€

10.00 - 1 15

NEW

VERIFICADOR DE FOLGAS NA SUSPENSÃO E DIREÇÃO



VIDEO TUTORIAL

Peças	1
Largura da jante	13-22"
Material	Acero/Steel
Peso	12,5Kg
Dimensões (CxLxA)	690x400x580mm

50827 387,00€

32.90 - 1 18

COMPRESSOR DE MOLAS PARA AMORTECEDORES



REPOSIÇÕES DISPONÍVEIS



VIDEO TUTORIAL

Capacidade	1T
Diâmetro da mola	200mm
Altura máxima	500mm
Peso	35,00Kg
Dimensões (CxLxA)	350x190x830mm



51991 68,00€

1.15 - 5 100

ALINHADOR DE DIREÇÃO



Peças	2
Abertura	1100-1950mm
Material	Al, Fe
Peso	1,15Kg
Dimensões (CxLxA)	1105x225x30mm

53118 231,00€

6.66 - 2 112

KIT PARA REMOÇÃO DE AMORTECEDOR



Peças	39
Material	CRV 6140, CRMO SCM415, CRV 50BV30
Peso	6,66Kg
Dimensões (CxLxA)	575x451x75mm

52541 45,00€

2.10 - 10 110

COMPROVADOR DE EIXOS



Peso	2,10Kg
Dimensões (CxLxA)	550x420x60mm



53742

1.325,00€

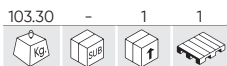

COMPRESSOR DE MOLA DE AMORTECEDOR PNEUMÁTICO 1T



VIDEO TUTORIAL

Capacidade	1T
Comprimento máximo de trabalho	450mm
Comprimento do curso do cilindro	420mm
Diâmetro da mola	102-165mm
Pressão de ar máxima	8BAR
Dimensões (CxLxA)	690x560x1410mm
Peso	63,40Kg

54963

2.190,00€



NEW

COMPRESSOR DE MOLA DE AMORTECEDOR PNEUMÁTICO 2T



Capacidade	2T
Comprimento máximo de trabalho	450mm
Comprimento do curso do cilindro	420mm
Diâmetro da mola	102-165mm
Pressão de ar máxima	9BAR
Dimensões (CxLxA)	1420x580x830mm
Peso	80,50Kg

53394

598,00€

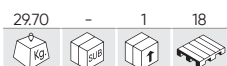

COMPRESSOR DE MOLAS UNIVERSAL HEAVY DUTY

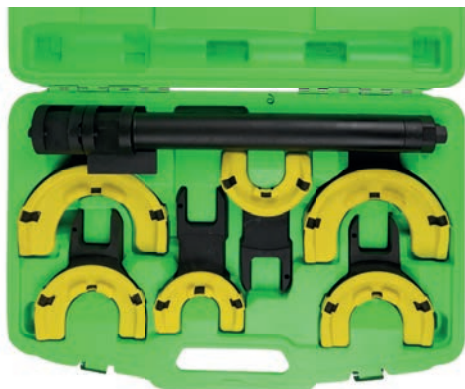

Peças	7
Carga máxima	10.200Nm
Peso	29,70Kg
Dimensões (CxLxA)	690x470x145mm

ADEQUADO PARA USO COM FERRAMENTAS PNEUMÁTICAS

52227

247,00€



COMPRESSOR DE MOLA PROFISSIONAL MCPHERSON

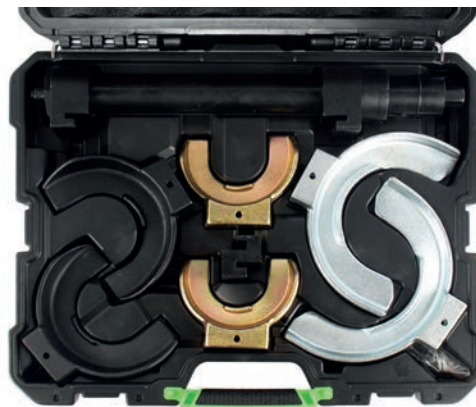

Peças	8
Carga máxima	2500Nm
Peso	15,10Kg
Dimensões (CxLxA)	530x445x130mm

NÃO USAR COM PISTOLA NEUMÁTICA

52270 117,00€



EXTRATOR DE CASQUILHOS PARA VAG

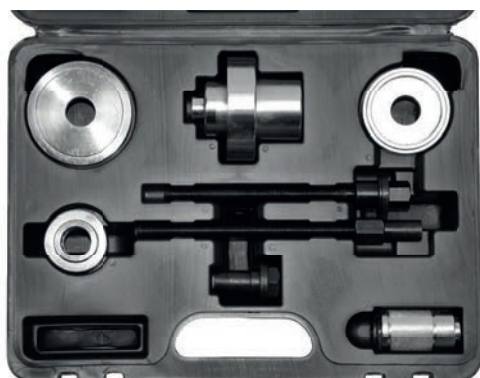

Peças	8
Peso	3,18Kg
Dimensões (CxLxA)	330x245x92mm

52432 35,00€



EXTRATOR DE CASQUILHOS FRONTAIS PARA VAG

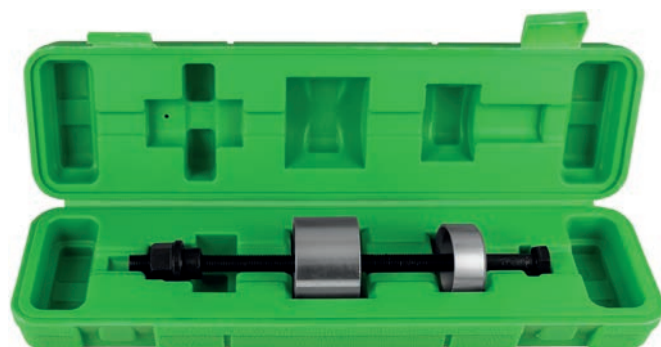

Compatível com	VW POLO 2002
Peso	1,80Kg
Dimensões (CxLxA)	400x100x70mm

55059 329,00€



NEW

CONJUNTO EXTRATOR/INSTALADOR DE ROLAMENTO DE RODA VAG



Peças	43
Peso	24,00Kg
Dimensões (CxLxA)	600x485x107mm

55054 57,50€



NEW

CONJUNTO EXTRATOR/INSTALADOR DE SILENT BLOCKS DO BRAÇO DE SUSPENSÃO DIANTEIRA VAG



Peças	5
Peso	3,50Kg
Dimensões (CxLxA)	255x160x87mm

55074 268,00€



NEW

CONJUNTO EXTRATOR/INSTALADOR DE SILENTBLOCK DO BRAÇO DE SUSPENSÃO TRASEIRO PARA TOYOTA

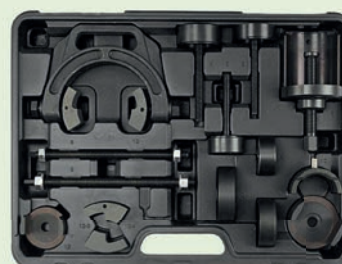

Peças	16
Peso	12,50Kg
Dimensões (CxLxA)	500x390x130mm



55056

57,00€

3.20 - 10 240



NEW

CONJUNTO EXTRATOR/INSTALADOR DE SILENT BLOCKS DO SUBCHASSI TRASEIRO RENAULT



Peças	4
Peso	2,91Kg
Dimensões (CxLxA)	330x250x95mm

55006

77,00€

2.00 - 10 480



NEW

EXTRATOR/INSTALADOR DE SILENTBLOCK DIANTEIRO PARA TESLA 3



Peças	3
Peso	1,90Kg
Dimensões (CxLxA)	370x250x80mm

55070

124,00€

6.20 - 2 80



NEW

CONJUNTO EXTRATOR/INSTALADOR DE SILENTBLOCK DO BRAÇO TRASEIRO PARA HONDA

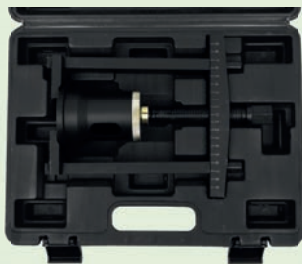

Peças	1
Peso	6,10Kg
Dimensões (CxLxA)	385x285x110mm

55072

37,50€

1.80 - 5 200



NEW

CONJUNTO INSTALADOR DE SILENTBLOCK DO EIXO TRASEIRO PARA FIAT



Peças	7
Peso	1,80Kg
Dimensões (CxLxA)	385x285x110mm

55064

113,00€

5.80 - 2 64



NEW

CONJUNTO EXTRATOR DE SILENTBLOCK PARA AUDI/VW

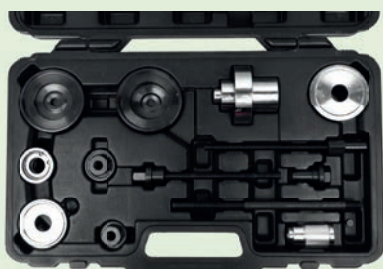

Peças	13
Peso	5,85Kg
Dimensões (CxLxA)	485x300x91mm

55052

48,00€

2.50 - 5 210



NEW

CONJUNTO DE MONTAGEM DE SILENT BLOCKS PARA EIXO TRASEIRO VW GOLF, AUDI A3



Peças	5
Peso	2,40Kg
Dimensões (CxLxA)	255x160x87mm

55053 43,00€

1.60 - 10 160 **NEW**

CONJUNTO DE EXTRAÇÃO/INSTALAÇÃO DE SILENT BLOCKS DA SUSPENSÃO TRASEIRA OPEL/VAUXHALL



Peças	8
Peso	1,60Kg
Dimensões (CxLxA)	255x165x87mm

54952 82,50€

6.10 - 2 72 **NEW**

CONJUNTO EXTRATOR/INSTALADOR DE SILENT BLOCKS OPEL/VAUXHALL



Peças	6
Peso	5,50Kg
Dimensões (CxLxA)	376x118x190mm

55067 101,00€

5.00 - 2 96 **NEW**

CONJUNTO EXTRATOR/INSTALADOR DE SILENTBLOCK DO SUBCHASSIS PARA MERCEDES-BENZ



Peças	8
Peso	5,00Kg
Dimensões (CxLxA)	335x250x94mm

54829 233,00€

23.00 - 1 35 **NEW**

FERRAMENTA DE MONTAGEM DE SILENTBLOCKS - SAF, MERCEDES



Peças	10
Material	Acero al carbono/Carbon Steel
Peso	23,00Kg
Dimensões (CxLxA)	550x380x300mm

55075 108,50€

8.00 - 2 64 **NEW**

CONJUNTO EXTRATOR/INSTALADOR DE SILENTBLOCK DO SUPORTE DE BORRACHA DA TRANSMISSÃO PARA BMW



Peças	8
Peso	8,00Kg
Dimensões (CxLxA)	450x300x90mm

55057 109,00€

6.60 - 2 80 **NEW**

CONJUNTO EXTRATOR/INSTALADOR DE SILENTBLOCK DO SUBCHASSIS TRASEIRO PARA BMW X5



Peças	6
Peso	6,65Kg
Dimensões (CxLxA)	380x290x110mm



55065 103,50€

6.40 - 2 80 **NEW**

CONJUNTO EXTRATOR/INSTALADOR DE SILENTBLOCK E RÓTULA PARA BMW

Peças	14
Peso	6,50Kg
Dimensões (CxLxA)	380x290x110mm

55068 123,00€

6.70 - 2 48 **NEW**

CONJUNTO EXTRATOR/INSTALADOR DE SILENTBLOCK DO SUBCHASSIS PARA BMW

Peças	11
Peso	6,70Kg
Dimensões (CxLxA)	335x250x95mm

55071 105,00€

3.95 - 4 96 **NEW**

CONJUNTO EXTRATOR/INSTALADOR DE SILENTBLOCK DO BRAÇO TRASEIRO PARA BMW

Peças	10
Peso	3,95Kg
Dimensões (CxLxA)	360x270x80mm

55055 56,00€

3.10 - 5 160 **NEW**

CONJUNTO EXTRATOR/INSTALADOR DE SILENT BLOCKS DA SUSPENSÃO DIANTEIRA BMW/MINI

Peças	8
Peso	3,10Kg
Dimensões (CxLxA)	255x160x87mm

55060 21,00€

1.10 - 10 360 **NEW**

CONJUNTO EXTRATOR/INSTALADOR DE SILENT BLOCKS DO BRAÇO TRASEIRO FORD MONDEO

Peças	4
Peso	1,10Kg
Dimensões (CxLxA)	235x195x55mm

55061 53,00€

1.60 - 10 160 **NEW**

CONJUNTO EXTRATOR/INSTALADOR DE BUCHAS DO SUBCHASSI TRASEIRO FORD MONDEO

Peças	6
Peso	1,60Kg
Dimensões (CxLxA)	255x160x87mm

55062 50,00€

2.20 - 5 210 **NEW**

CONJUNTO EXTRATOR/INSTALADOR DE SILENT BLOCKS DO SUBCHASSI TRASEIRO FORD FIESTA



Peças	6
Peso	2,20Kg
Dimensões (CxLxA)	255x160x87mm

55063 127,00€

10.00 - 1 60 **NEW**

CONJUNTO EXTRATOR/INSTALADOR DE ROLAMENTO DE RODA FORD/LAND ROVER/VOLVO



Peças	19
Peso	10,00Kg
Dimensões (CxLxA)	383x260x110mm

55069 99,00€

6.20 - 2 80 **NEW**

CONJUNTO EXTRATOR/INSTALADOR DE SILENTBLOCK DO SUBCHASSIS TRASEIRO PARA FORD



Peças	4
Peso	6,30Kg
Dimensões (CxLxA)	385x285x110mm

55073 62,00€

1.70 - 5 200 **NEW**

CONJUNTO EXTRATOR/INSTALADOR DE POLIA TRASEIRA DO ÁRVORE DE COMANDO PARA FORD/MAZDA



Peças	6
Peso	3,95Kg
Dimensões (CxLxA)	360x270x80mm

54948 151,50€

10.00 - 1 52 **NEW**

EXTRATOR/INSTALADOR DE SILENT BLOCK DO BRAÇO DE ARRASTO TRASEIRO



Peças	5
Peso	8,30Kg
Dimensões (CxLxA)	390x290x110mm

55058 143,50€

10.00 - 1 40 **NEW**

CONJUNTO EXTRATOR/INSTALADOR DE SILENT BLOCKS DO BRAÇO TRASEIRO VOLVO/FORD



Peças	7
Peso	6,00Kg
Dimensões (CxLxA)	330x280x70mm



55077



NEW

CONJUNTO EXTRATOR/INSTALADOR DE ROLAMENTOS DE RODA - 78MM

Peças	13
Peso	10,40Kg
Dimensões (CxLxA)	390x350x140mm



138,00€

54897



NEW

KIT DE FERRAMENTAS DE CASQUILHOS DE FENDA PARA ROLAMENTO SILENCIOSO

Peças	19
Compatível com	54257
Peso	17,00Kg
Dimensões (CxLxA)	390x420x130mm



790,00€

55003



NEW

CONJUNTO HIDRÁULICO DE EXTRAÇÃO/INSTALAÇÃO DE SILENTBLOCKS E ROLAMENTOS (63PCS)

Peças	63
Compatível com	54257
Peso	33,00Kg
Dimensões (CxLxA)	860x390x180mm



849,00€

52494

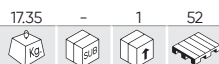

FERRAMENTA UNIVERSAL DE REMOÇÃO / INSTALAÇÃO DE ROLAMENTOS E CÁSQUILHOS

Medidas	M10, M12, M16, M18
Adaptadores (diâmetro externo/interno)	90/80, 85/75, 82/72, 80/70, 78/68, 76/66, 74/64, 72/62, 70/60, 68/58, 66/56, 64/54, 62/52, 60/50, 58/48, 56/46, 54/44, 52/42, 50/40, 48/38, 46/36, 44/34



227,00€



REPOSIÇÕES DISPONÍVEIS

EXTRATOR PARA BRAÇO DE DIREÇÃO

REF.	DESCRIÇÃO					€
52874	EXTRATOR PARA BRAÇO DE DIREÇÃO Ø 9-20MM	1.20	4	20	1500	85,00€
52875	EXTRATOR PARA BRAÇO DE DIREÇÃO Ø 14-23MM	1.25	5	20	1500	88,00€



EXTRATOR PARA BRAÇO DE DIREÇÃO

REF.	DESCRIÇÃO					€
52640	EXTRATOR PARA BRAÇO DE DIREÇÃO Ø 28-35MM	1.80	-	4	240	52,00€
52641	EXTRATOR PARA BRAÇO DIREÇÃO Ø 35-45MM	2.20	-	4	148	55,00€



EXTRATOR

REF.	DESCRIÇÃO					€
51368	CHAVE UNIVERSAL DE BARRA DE DIREÇÃO INTERNA	0.41	-	50	3500	19,00€
51369	EXTRATOR DE PORCAS FÊMEAS AXIAIS	0.55	6	36	2016	28,00€
51414	EXTRATOR DE PERNOS	0.59	-	40	1440	14,00€



51368



51369



51414

53638 243,00€

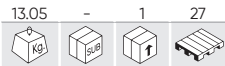

EXTRATOR HIDRÁULICO DE BUCHAS DA RODA



REPOSIÇÕES DISPONÍVEIS



Peças	8
Comprimento	570mm
Marcas	Multimarca/Multi-brand
Peso	13,35Kg
Dimensões (CxLxA)	590x360x130mm

54953 89,00€

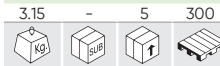

NEW

FERRAMENTA UNIVERSAL PARA REMOÇÃO DE CUBO DE RODA



Peças	4
Peso	3,10Kg
Dimensões (CxLxA)	280x230x67mm

53635 91,00€

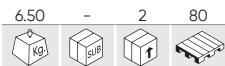

EXTRATOR DE ROLAMENTOS COM PLACA DESLIZANTE



Diâmetro	100-115mm
Comprimento	630mm
Peso	6,50Kg

54595 18,50€

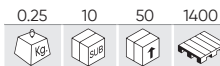

FERRAMENTA DE ESPALHAMENTO DO SUPORTE DE SUSPENSÃO



Abertura	5-30mm
Peso	0,65Kg
Dimensões (CxLxA)	85x32x40mm

54560 20,00€

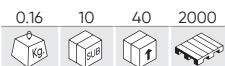

FERRAMENTA DILATADORA DE ESCORAS DE SUSPENSÃO



Abertura	5-11,5mm
Peso	0,16Kg
Dimensões (CxLxA)	310x270x195mm

52642 32,00€

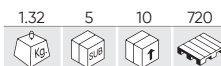

EXTRATOR DE JUNTAS ESFÉRICAS UNIVERSAIS



Peças	1
Abertura	55-60mm
Diâmetro	17-22mm
Peso	1,32Kg

52699 22,00€

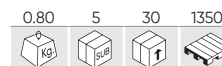

EXTRATOR DE JUNTAS ESFÉRICAS AJUSTÁVEL



Peças	1
Abertura	15-55mm
Diâmetro	19-23mm
Peso	0,70Kg

51123



JOGO 5 EXTRATORES DE RÓTULA

	A	B	C	D	E
Abertura	18mm	33mm	250mm	18mm	22mm
Abertura (dentro)	45mm	55mm	0mm	25mm	20mm
Dimensões	50x18mm	55x28mm	160x75x16mm	50x28 mm	80x43x45mm
Dirigir	19mm	19mm	17mm	19mm	21mm
Fuso	M16x1,5	M16x1,5	14mm	M12x1,75	M16x1,5



91,00€

53384

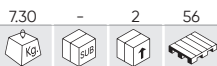

EXTRATOR DE RÓTULAS HIDRÁULICO

Peças	5
Capacidade	10T
Abertura	100mm
Largura	35mm
Passo da rosca do fuso hidráulico	11/2"
Peso	7,30Kg



REPOSIÇÕES DISPONÍVEIS

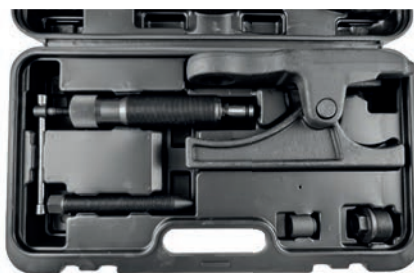

173,00€

54513

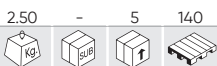

CONJUNTO DE 5 EXTRATORES DE RÓTULA DE GARFO PARA MARTELO PNEUMÁTICO



REPOSIÇÕES DISPONÍVEIS



x5 20, 24, 30, 35, 42mm

75,00€

51490



KIT DE EXTRATORES DE RÓTULAS



- x1 Cabo para usar com um martelo
- x1 Cabo desenhado para utilizarse com um martelo pneumático
- x3 Forquilhas: 11/16, 15/16" e 1-1/8"

36,00€

53488



ALINHADOR DE QUEDAS (VAG)



- x1 75mm Seat - Toledo | VW - Jeta / Golf
- x1 115mm Chrysler - Voyager
- x1 85mm Seat - Cordoba | VW - Polo / 95>
- x1 22mm

66,00€

54958



NEW

KIT EXTRATOR DE RÓTULAS 4 EM 1



Peças	10
Peso	6,70Kg
Dimensões (CxLxA)	375x195x110mm

66,00€

51119

62,00€

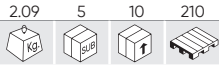

KIT DE 7 PEÇAS PARA SISTEMA DE INJEÇÃO - LAMBDA



x1	Chave de 1/2" de 29x9 a 90mm de comprimento
x1	Chave de 1/2" de 7/8" a 50mm de comprimento
x1	Chave de 1/2" de 27x12 a 78mm de comprimento
x1	Chave de 3/8" de 7/8" x 6 a 90mm de comprimento
x1	Chave de 3/8" de 7/8" x 6 a 80mm de comprimento
x1	Chave de 3/8" de 7/8" a 30mm de comprimento
x1	Chave de 3/8" de 1" e 1-1/16" a 74mm de comprimento

51491

154,00€



KIT DE 14 PEÇAS PARA O SISTEMA DE INJEÇÃO LAMBDA



17mm	78mm	BMW, Mercedes Benz, Renault	22mm	110mm	Audi, BMW, Mercedes Benz, VW, Volvo
19mm	78mm	VW, Audi, Seat	22mm	150mm	BMW
20mm	80mm	Universal	27mm	78mm	Universal
1/2" 21mm	85mm	Ford, VAG	1/2" 27mm	80mm	BMW, Fiat, Ford, Peugeot
22mm	50mm	Universal	27mm	110mm	PSA
22mm	30mm	Universal	28mm	78mm	Volvo, Scania, HGV
22mm	90mm	Universal	30mm	78mm	Bosch, General motors, Mercedes-Benz

52822

32,00€

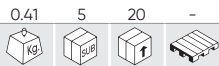

CHAVE PARA SONDA LAMBDA ARTICULADA 22MM



Medida do quadrado	22mm
Perfil	Hexagonal
Tipo	Articulado/Articulate
Peso	0,41Kg
Comprimento	265mm

52849

8,50€

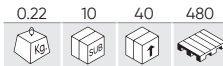

SET DE 2 GANCHOS PARA EXTRAIR BORRACHA DA TUBO DE DESCARGA



Peças	2
Peso	0,22Kg
Dimensões (CxA)	215x100mm, 203x100mm

52637

48,00€



KIT DE EXPANSÃO PARA TUBOS DE ESCAPE



x1	1-1/8" - 1-3/4"
x1	1-1/2" - 2-1/2"
x1	2-1/8" - 3-1/2"

51495

59,00€



EXTRATOR DE BOBINA DE IGNIÇÃO PARA VW



Peças	4
Peso	0,96Kg
Dimensões (CxLxA)	215x210x170mm

52621

11,00€

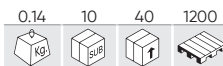

LIMPADOR DE TERMINAIS DE BATERIA



Peças	2
Medidas	80x38,5mm
Peso	0,14Kg

52319

8,80€

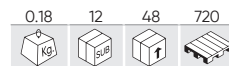

LIMPADOR DE TERMINAIS DE BATERIA



Peças	1
Medidas	122, 107mm
Peso	0,13Kg

52293

98,00€

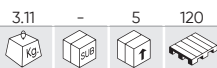

KIT DE EXTRAÇÃO DE POLIAS DE 30 PEÇAS

1	1/2" x T50 - 33 Teeth	16	Especial
2	1/2" x M10 - 33 Teeth	17	1/2" x M10
3	H15 x 33 Teeth	18	3/8" x M10 - 31 Teeth
4	H22 x 33 Teeth	19	Especial
5	H22	20	Especial
6	H17 x 4 Pin	21	Especial
7	1/2" x H10	22	Especial
8	H8 x H10	23	M10 x H12
9	H10 x H10	24	T50 x H12
10	M8 x H10	25	Especial
11	M10 x H10	26	Especial
12	T40 x H10	27	3/8" x 10mm
13	T50 x H10	28	1/2" x T50
14	H10 x FH10	29	1/2" x T50
15	Especial	30	1/2" x M10

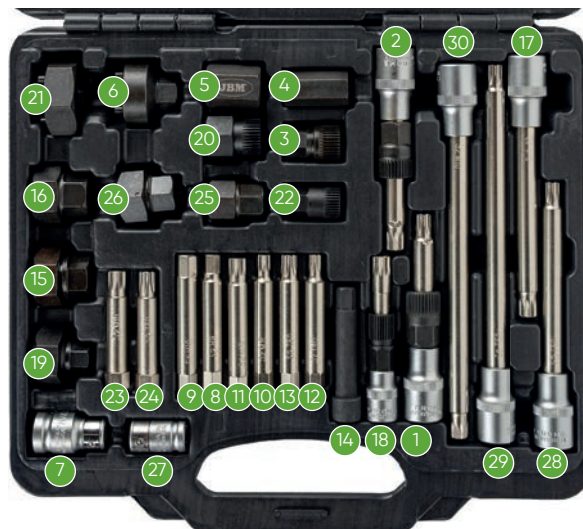

REPOSIÇÕES DISPONÍVEIS

51259

58,00€

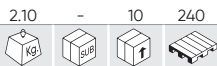

KIT DE EXTRAÇÃO DE POLIAS 18 PEÇAS

A	x3	T50x110mm (1/2"), M10x110 (1/2"), M10x90mm (3/8")
B	x1	M10x140mm
C	x2	19, 22mm
D	x3	22x28, 19x28, 21x28mm
E	x1	1/2"x10mm
F	x1	M10x65mm
G	x6	T40, T50, M8, M10, H8, H10 (10x75mm)
H	x1	H22



REPOSIÇÕES DISPONÍVEIS



EXTRATOR DE CONEXÕES DE AQUECEDOR

REF.	DESCRIÇÃO	kg	cm³	cm	cm	cm	€
52816	EXTRATOR DE CONEXÕES DE AQUECEDOR - BOCA EM ÂNGULO - 235MM	0.27	6	36	-	-	30,00€
52817	EXTRATOR DE CONEXÃO DE AQUECEDOR- BOCA RETO 250MM	0.28	6	36	-	-	28,50€



52816



52817



CHAVE DE VELA MAGNÉTICA

REF.	mm						€
52316	Ø14mm	0.20	12	48	3360		18,90€
52317	Ø 16mm	0.30	12	48	2880		19,90€



CHAVE DE VELAS HEX.

REF.	mm						€
10054	1/2" - 16mm	0.08	10	100	-		2,90€
10055	1/2" - 21mm	0.14	10	100	-		3,90€



52691

54,00€



CHAVE DE VELA ARTICULADA

- 3/8" 8mm (82mm)
- 3/8" 9mm (82mm)
- 3/8" 10mm (82mm)
- 3/8" 12mm (82mm)
- 3/8" 14mm (82mm)
- 3/8" 16mm (82mm)

COM FIXAÇÃO MECÂNICA



CHAVE DE VELA MAGNÉTICA

REF.	mm						€
54381	14mm	0.35	10	40	840		5,50€
54382	16mm	0.35	10	40	840		5,50€
54383	21mm	0.35	10	40	840		5,50€



53663

8,00€

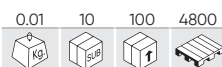

FERRAMENTA DE DESMONTAGEM DE CONECTORES PARA VAG



Peso 0,10Kg
Dimensões (CxLxA) 140x15x100mm

51501

38,00€

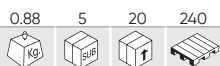

KIT PARA EXTRAÇÃO DE AIRBAGS



- T25 (BMW)
- T30 (AUDI, OPEL, RENAULT, VW)
- T25 (BMW)
- T30 (AUDI, OPEL, RENAULT, VW)
- 5mm (AUDI)
- 5-1/4"x 87mm (L)

53388

94,00€



TRUSĂ DE 52 PEÇAS PARA EXTRAÇÃO DE EQUIPAMENTOS DE AUDIO



51126

18,00€

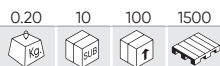

KIT DE ACESSÓRIOS PRA EXTRAIR EQUIPAMENTOS ÁUDIO



Peças	20
Peso	0,20Kg
Dimensões (CxLxA)	125x76x50mm

51986

11,90€



RECÂMBIO DE GAS 200ML



Capacidade	200ml
Peso	0,18Kg
Dimensões (CxLxA)	17,2x50x50mm

51920

18,00€

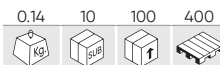

MAÇARICO



Peso	0,15Kg
Dimensões (CxLxA)	220x165x75mm

55015

59,00€

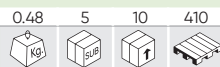

NEW

KIT DE SOLDADOR A GÁS COM IGNIÇÃO AUTOMÁTICA



Peças	10
Material	PP, Cu, Al
Temperatura de trabalho	450-1300°C
Capacidade	20ml
Peso	0,10Kg
Dimensões (CxLxA)	209x25x25mm

53393

118,00€

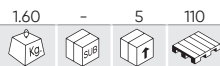

KIT DE 23 EXTRATORES DE TERMINAIS



Peças	23
Peso	1,60Kg
Dimensões (CxLxA)	435x250x70mm

53391

92,00€

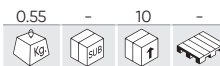

KIT DE 19 EXTRATORES DE TERMINAIS

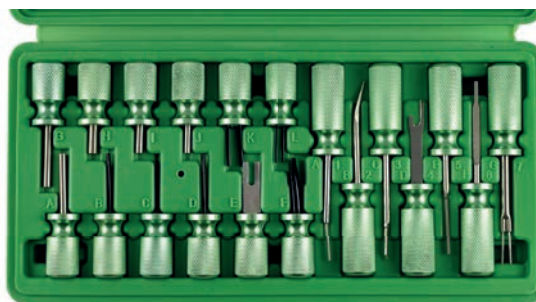

Peças	19
Peso	0,55Kg
Dimensões (CxLxA)	245x125x40mm

53474 94,00€

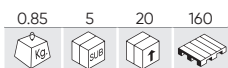

PISTOLA ESTROBOSCÓPICA DIGITAL



Tensão	12V
Potência	3.6W
Precisão	0,1°
Velocidade máxima de rotação	9000RPM
Comprimento do cabo	1800mm

53240 58,00€

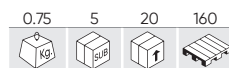

PISTOLA ESTROBOSCÓPICA



Tensão	12V
Potência	3.6W
Precisão	1°
Velocidade máxima de rotação	10000RPM
Comprimento do cabo	1500mm

KIT REPARADOR DE ROSCAS HELICÓIDAS

REF.	DESCRIÇÃO					€
53041	KIT REPARADOR DE ROSCAS HELICÓIDAS M14X1,25	0.54	-	10	1000	37,60€
51898	KIT REPARADOR DE ROSCAS HELICÓIDAS M18X2,5	1.81	-	4	252	139,00€
51899	KIT REPARADOR DE ROSCAS HELICÓIDAS M20X2,5	2.12	-	5	252	147,00€



53041



51898 - 51899



51898
REPOSIÇÕES
DISPONÍVEIS



51899
REPOSIÇÕES
DISPONÍVEIS

51896 82,00€



KIT REPARADOR DE ROSCAS HELICÓIDAS 115PÇS



REPOSIÇÕES
DISPONÍVEIS



CONTÉM POR MEDIDA	CONTÉM
Broca	25 x M5x0.8
Macho de roscar	25 x M6x1
Chave helicoidal	25 x M8x1.25
Punção de ruptura	25 x M10x1.5
Conjunto helicóide aço Inox	10 x M12x1.75

51897 125,00€



KIT REPARADOR DE ROSCAS HELICÓIDAS



REPOSIÇÕES
DISPONÍVEIS



CONTÉM POR MEDIDA	CONTÉM
Broca	9 x M12x1.75
Macho de roscar	9 x M14x2
Chave helicoidal	9 x M16x 2.0
Punção de ruptura	
Conjunto helicóide aço Inox	

50793

94,00€

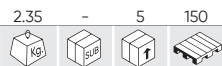

KIT FERR. CORTE 60 P. MACHOS E CAÇONETES. MÉTRICO E PULGADA



- x1 NPT macho (pol.): 1/8-27.
- x1 NPT caçonete (pol.): 1/8-27.
- x1 Porta Macho misto tip: M3 ~ M12 e 3/16 "a 1/2".
- x1 Porta Macho misto tip: M3 ~ M6 ~ 6-32 e 4-40
- x1 Porta caçonetes misto: Ø25mm
- x1 Chave de fenda
- x1 Jogo de galgas métricas para roscar.
- x1 Jogo de galgas métricas para roscar.
- x10 Machos (métricos): M3x0.5, M4x0.7, M5x0.8, M6x1.0, M7x1.0, M8x1.25, M9x1.25, M10x1.0, M10x1.5, M12x1.75.
- x10 Machos UNC (pulgadas): 4-40, 10-24 6-32, 8-32, 12-24, 1/4-20, 5/16-18, 3/8-16, 7/16-14, 1/2-13.
- x6 Caçonetes UNF (pulgadas): 10-32, 1/4 -28, 5/16-24, 3/8-24, 7/16-20, 1/2-20.
- x10 Caçonetes (métricos): M3x0.5, M4x0.7, M5x0.8, M6x1.0, M7x1.0, M8x1.25, M9x1.25, M10x1.0, M10x1.5, M12x1.75.
- Caçonetes UNC (pulgadas): 4-40, 10-24 6-32, 8-32, 12-24, 1/4-20, 5/16-18, 3/8-16, 7/16-14, 1/2-13.
- x6 Caçonetes UNF (pulgadas): 10-32, 1/4-28, 5/16-24, 3/8-24, 7/16-20, 1/2-20.

54280

175,00€

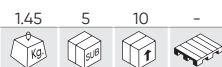

KIT DE REPARACIÓN DE ROSCAS DE BUJÍAS

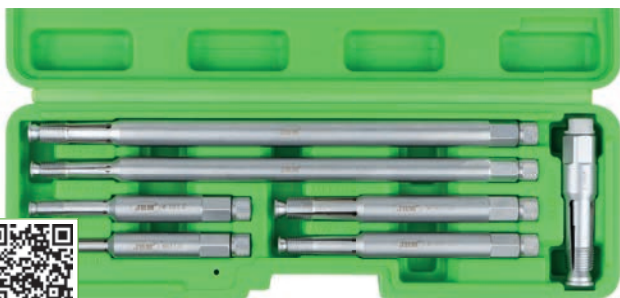

REPOSIÇÕES DISPONÍVEIS

Peças	7
Peso	1,45Kg
Dimensões (CxLxA)	325x105x55mm

50792

105,00€



KIT FERR CORTE 58P. MACHOS E CAÇONETES RECOBERTAS DE TITÂNIO



- x1 Macho e 1 caçonete tipo NPT: 1/8-27.
- x1 Macho e 1 caçonete tipo TPN: 1/8-27.
- x1 Porta Macho: M4 ~ M12.
- x1 Porta Machos tipo: M3 ~ M6.
- x1 Porta caçonete: 25mm O / D.
- x1 Chave de fenda.
- x1 Jogo de galgas para roscar.
- Machos: M2x0.4 (x2), M3x0.6 (x2), M3x0.5 (x2), M3.5x0.6 (x2), M4x0.75 (x2), M4x0.7 (x2), M5x0.8 (x2), M6x0.75 (x2), M6x1.0 (x2), M7x0.75 (x2), M7x1.0 (x2), M8x1.0 (x2), M8x1.25 (x2), M10x1.25 (x2), M10x1.5 (x2), M12x1.25 (x2), M12x1.75 (x2)
- x17 Caçonetes: M2x0.4, M3x0.6, M3x0.5, M3.5x0.6, M4x0.75, M4x0.7, M5x0.8, M6x0.75, M6x1.0, M7x0.75, M7x1.0, M8x1.0, M8x1.25, M10x1.25, M10x1.5, M12x1.25, M12x1.75

54003

110,00€

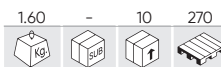

KIT DE REPARAÇÃO DE ROSCAS INTERNAS E EXTERNAS



Peças	9
Peso	1,60Kg
Dimensões (CxLxA)	250x200x65mm

53652 56,00€

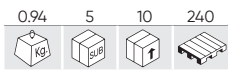

KIT DE REPARAÇÃO DE ROSCA PARA PINOS DE RODA



REPOSIÇÕES DISPONÍVEIS



Peças	8
Peso	0,94Kg
Dimensões (CxLxA)	260x160x60mm

53055 33,00€

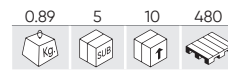

CORTADOR E REBITADOR DE CORRENTE DE MOTOCICLETAS



Peças	11
Peso	0,89Kg
Dimensões (CxLxA)	220x115x55mm

53665 19,00€

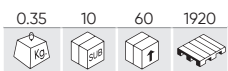

CORTADOR DE CORRENTE DE MOTOCICLETA (25-60)



Faixa	25-60mm
Peso	0,35Kg
Dimensões (CxLxA)	175x90x22mm

53666 28,00€

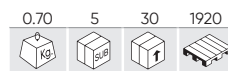

CORTADOR DE CORRENTE DE MOTOCICLETA (60-100)



Faixa	60-100mm
Peso	0,70Kg
Dimensões (CxLxA)	195x110x30mm

53054 6,00€

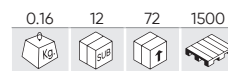

CHAVE ESPECIAL PARA MOTAS



Medidas	19, 22, 24mm
Peso	0,16Kg
Dimensões (CxLxA)	130x70x30mm

53086 9,00€

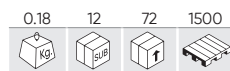

CHAVE PARA MOTAS



Medidas	17, 19, 22, 24mm
Peso	0,18Kg
Dimensões (CxLxA)	170x80x30mm

53701 188,00€

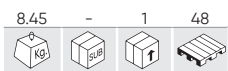

KIT UNIVERSAL DE EXTRATORES DE 2/3 GARRAS



REPOSIÇÕES DISPONÍVEIS



Peças	13
Faixa	45-120mm/50-130mm
Profundidade	165, 275mm
Peso	8,45Kg
Dimensões (CxLxA)	540x363x110mm



EXTRATOR DE 2 GARRAS

REF.	DESCRIÇÃO	—	I					€
52727	EXTRATOR DE 2 GARRAS 25-70MM	25-70mm	50mm	0.20	10	60	1200	35,00€
52728	EXTRATOR DE 2 GARRAS 25-130MM	25-130mm	110mm	1.20	5	10	500	68,00€
52729	EXTRATOR DE 2 GARRAS 60-200MM	60-200mm	160mm	3.26	-	3	240	128,00€
52730	EXTATOR 2 GARRAS 80-350MM	80-350mm	225mm	8.55	-	2	108	288,00€



REF.	DESCRIÇÃO					€
53146	EXPOSITOR DE EXTRADORES	0.70	5	10	140	31,50€

EXTRATOR DE 3 GARRAS

REF.	DESCRIÇÃO	—					€
52731	EXTRATOR DE 3 GARRAS DE 50-100MM	50-100mm	0.90	4	24	504	38,00€
52732	EXTRATOR DE 3 GARRAS 70-150MM	70-150mm	2.54	-	20	300	58,00€
52733	EXTRATOR DE 3 GARRAS DE 95-200MM	95-200mm	5.20	-	4	112	98,00€



EXTRATOR DE 3 GARRAS CONVERSÍVEL EM 2 REVERSÍVEL

REF.	DESCRIÇÃO	T					€
52010	EXTRATOR DE 3 GARRAS CONVERSÍVEL EM 2 REVERSÍVEL 2T	2T	0.50	4	40	360	86,00€
52296	EXTRATOR DE 3 GARRAS CONVERSÍVEL EN 2 REVERSÍVEL 5T	5T	1.57	4	8	120	119,00€
52297	EXTRATOR DE 3 GARRAS CONVERSÍVEL EM 2 REVERSÍVEL 7T	7T	3.33	-	6	36	192,00€
52298	EXTRATOR DE 3 GARRAS CONVERSÍVEL EM 2 REVERSÍVEL , GARRA CURTA E LONGA	2T	2.65	3	6	396	177,00€



51125

88,00€

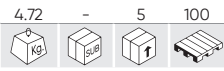

KIT DE EXTRATORES DE GUILHOTINA

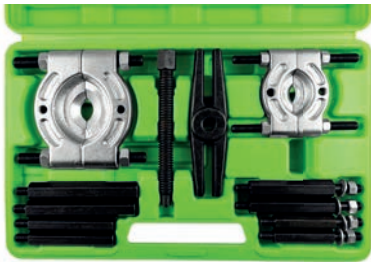

x1	Ø50-75mm	x2	3/8" - 16x128mmL
x1	Ø30-50mm	x2	3/8" - 16x104mmL
x1	T16x3x170mmL	x2	3/8" - 16x128mmL
x1	160mmL	x2	3/8" - 16x105mmL

52626

49,00€

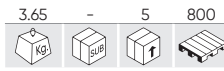

EXTRACTOR DE GUILHOTINA 75-105MM



Peças	3
Abertura	75-105mm
Peso	3,65Kg
Dimensões (CxLxA)	293x172x43mm

52627

120,00€

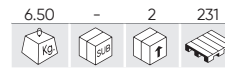

EXTRACTOR DE GUILHOTINA 105-150MM



Peças	3
Abertura	105-150mm
Peso	6,50Kg
Dimensões (CxLxA)	290x290x40mm

53062

99,00€

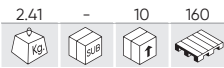

KIT DE EXTRATORES DE ROLAMENTOS COM ESFERAS FALSAS



Peças	23
Peso	2,41Kg
Dimensões (CxLxA)	365x265x50mm

52551

151,00€



KIT PARA EXTRAÇÃO DE ROLAMENTOS



Peças	20
Peso	10,42Kg
Dimensões (CxLxA)	445x300x90mm

54954

144,00€

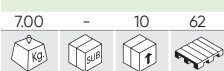

NEW

UTIL PARA ROLAMENTOS E ANÉIS SENSORES ABS



Peças	9
Peso	7,30Kg
Dimensões (CxLxA)	315x240x50mm

54955

109,00€

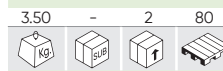

NEW

KIT EXTRATOR/INSTALADOR DE RETENTORES E ROLAMENTOS

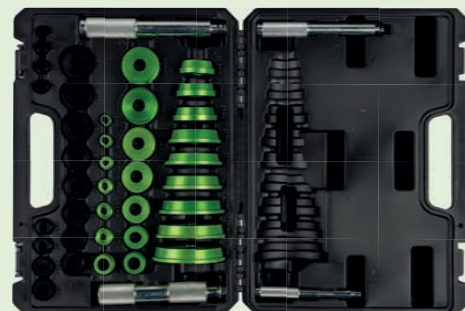

Peças	43
Peso	2,60Kg
Dimensões (CxLxA)	330x240x115mm

53058

193,00€

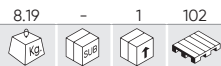

KIT DE MONTAGEM PARA ROLAMENTOS



Peças	51
Peso	8,19Kg
Dimensões (CxLxA)	335x245x90mm

53056

127,00€

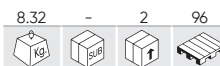

KIT DE EXTRAÇÃO E INSTALAÇÃO DE ROLAMENTOS



Peças	19
Peso	8,33Kg
Dimensões (CxLxA)	535x305x80mm

51349

38,00€

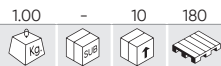

KIT PARA INSTALAÇÃO DE ROLAMENTOS



Peças	17
Peso	1,00Kg
Dimensões (CxLxA)	280x195x65mm

53059

56,00€

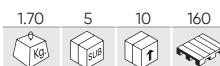

KIT DE INSTALAÇÃO DE ROLAMENTOS E FREIOS INTERIORES



Peças	10
Peso	1,70Kg
Dimensões (CxLxA)	255x150x102mm

53250

88,00€

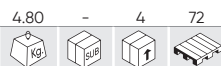

KIT DE EXTRATORES DE ROLAMENTOS INTERNOS E EXTERNOS



A	x1	30-80mm
B	x1	15-30mm
C	x1	15-80mm
D	x1	470x86mm
E	x1	55x22mm

51124

88,00€



KIT DE EXTRAÇÃO DE ROLAMENTOS



Peças	5
Peso	3,20Kg
Dimensões (CxLxA)	480x190x58mm

54299

246,00€

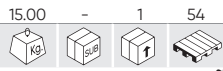

KIT DE REMOÇÃO E INSTALAÇÃO DE BUCHAS DE RODA E ROLAMENTOS

	530mm		860x109mm
	580mm	B	820x100mm
	650mm		710x9,45mm
	660mm		890x176mm
A	Ø 230mm	C	990x176mm
	710mm		120x178mm
	730mm	D	Ø 230mm 950mm
	780mm	E	Ø 860mm 955mm
	830mm	F	240x280cm

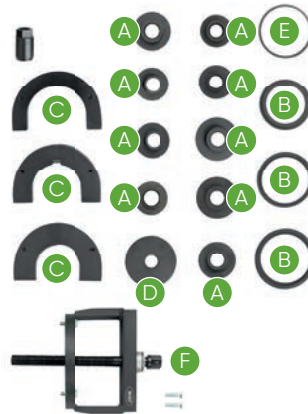

55078

107,00€

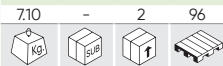

NEW

CONJUNTO EXTRATOR/INSTALADOR DE ROLAMENTO DE RODA VAG 62MM

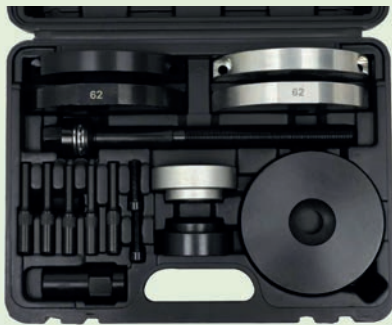

Peças	16
Peso	7,20Kg
Dimensões (CxLxA)	335x253x93mm

55079

107,00€



NEW

CONJUNTO EXTRATOR/INSTALADOR DE ROLAMENTO DE RODA 66MM VAG



Peças	16
Peso	7,20Kg
Dimensões (CxLxA)	335x253x93mm

55080

107,00€



NEW

CONJUNTO EXTRATOR/INSTALADOR DE ROLAMENTO DE RODA VAG 72MM

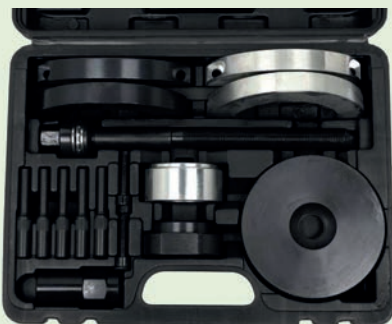

Peças	17
Peso	7,20Kg
Dimensões (CxLxA)	340x247x95mm

55081

109,50€



NEW

CONJUNTO EXTRATOR/INSTALADOR DE ROLAMENTO DE RODA 85MM VAG

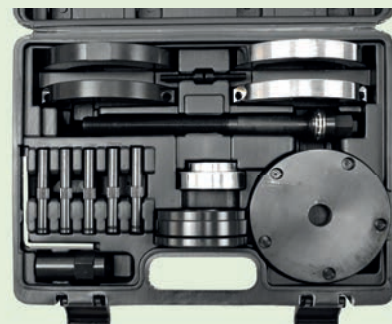

Peças	19
Peso	8,70Kg
Dimensões (CxLxA)	385x285x110mm

55082

129,00€



NEW

CONJUNTO EXTRATOR/INSTALADOR DE ROLAMENTO DE RODA VAG 62, 66, 72MM



Peças 19
Peso 13,00Kg
Dimensões (CxLxA) 475x415x108mm

54455

79,00€



SAC POLIA DO EIXO-COMANDO DE VÁLVULAS VAG



INFORMAÇÕES ADICIONAIS

54419

68,50€

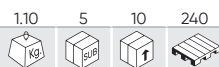

EXTRACTOR/INSTALADOR DO VEDANTE FRONTAL DA EIXO DE MANIVELAS FORD DURATORQ 2.0, 2.2, 2.4, 3.2



INFORMAÇÕES ADICIONAIS

54460

182,50€

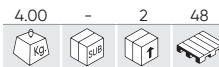

INSTALADOR DO VEDANTE DA CAMBOTA MERCEDES



INFORMAÇÕES ADICIONAIS

53457

181,50€

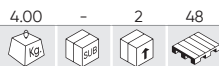

INSTALADOR DO VEDANTE DA CAMBOTA MERCEDES OM 651



INFORMAÇÕES ADICIONAIS

53875

137,00€



EXTRACTOR/INSTALADOR DE CAMBOTA (GRUPO VAG)



INFORMAÇÕES ADICIONAIS

53664

38,00€

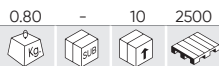

EXTRACTOR DE POLIAS UNIVERSAL



53129

90,00€

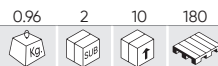

INSTALADOR AJUSTÁVEL DE RETENS 18-90MM



52819

22,00€

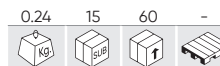

CHAVE 1/2" PARA CAMARA COMBUSTIÓN (MERCEDES)



52624



EXTRACTOR DE POLIAS ARMÓNICO

A	x1	Giratória flutuante	E	x2	M8x100mm
B	x1	Ponta rotativa de 3/4"	F	x3	M8x50mm
C	x11	Conjunto de anilhas	G	x2	M6x75mm
D	x1	M16x160mm	H	x3	M6x50mm



28,00€

54886



NEW

CONJUNTO DE EXTRACTOR/INSTALADOR DO VEDANTE DA CAMBOTA

A	x4	10, 18, 22, 27mm
B	x7	28, 34, 42, 46, 49, 56, 64mm
C	x7	M8, M10, M12, M14, M16, M18, M20
D	x1	Bisel de montagem
E	x1	Extractor



91,00€

53463



KIT DE EXTRAÇÃO DE BRAÇO DE LIMPA PRARA-BRISAS

Peças	6
Marcas	VOLKSWAGEN, OPEL, HONDA, BMW, AUDI, FORD, MERCEDES BENZ
Peso	1,65Kg
Dimensões (CxLxA)	275x230x60mm



98,00€

52454

13,90€



EXTRACTOR DE BRAÇO DE LIMPA-PÁRA-BRISAS



54736

22,50€

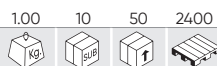

FERRAMENTA DE DESMONTAGEM PARA POLIA DA CAMBOTA PARA FORD



53696

23,50€

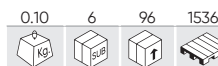

EXTRACTOR DE ABRAÇADEIRAS HENN



52852

6,80€

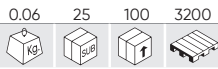

CONJUNTO DE 2 GANCHOS PARA O-RINGS



Peças	2
Peso	0,06Kg
Comprimento	210mm

53053

12,00€

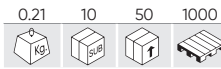

GANCHOS PARA EXTRAIR JUNTAS



Peças	3
Compatível com	Juntas tóricas/O-rings, Retenes/Seals
Material	Goma/Rubber, CrV
Peso	0,20Kg
Comprimento	120, 155, 165mm

51500

31,50€

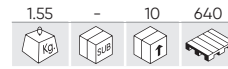

EXTRACTOR DE POLIAS ENCRAVADAS



Peças	2
Faixa	40-168mm
Peso	1,55Kg
Dimensões (CxLxA)	230x90x45mm

51496

8,00€

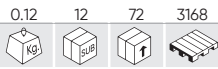

EXTRATOR DE PARAFUSOS PARTIDOS



Peças	5
Peso	0,12Kg
Dimensões (CxLxA)	170x90x20mm

53502

41,00€

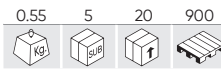

KIT EXTRATOR DE MACHOS DE ROSCAR QUEBRADOS



Peças	9
Peso	0,55Kg
Dimensões (CxLxA)	195x100x35mm

53669

45,00€

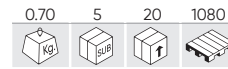

JOGO DE CHAVES DE CAIXA ESPECIAL PARA AUTOMÓVEL DE 10 PCS



Peças	10
Peso	0,70Kg
Dimensões (CxLxA)	350x80x25mm

54253

166,00€

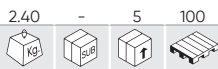

KIT DE REMOÇÃO DE PARAFUSO DE SEGURANÇA DA RODA



VÍDEO TUTORIAL



REPOSIÇÕES DISPONÍVEIS

Peças	10
Peso	2,40Kg
Dimensões (CxLxA)	300x62x225mm

53524

55,00€

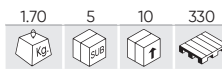

KIT DE 4 UNIDADES CORTAR PORCAS



REPOSIÇÕES DISPONÍVEIS

Peças	4
Faixa de trabalho	9-27mm
Peso	1,70Kg
Dimensões (CxLxA)	270x195x50mm

52802

54,00€

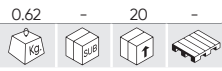

KIT DE PARAFUSO DE SEGURANÇA PARA BMW



Peças	10
Medida do quadrado	1/2"
Peso	0,62Kg
Dimensões (CxLxA)	250x120x50mm

52833

39,30€

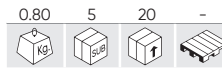

KIT DE CHAVES EXTRACTOR DE PERNOS 1/2"



REPOSIÇÕES DISPONÍVEIS

Peças	4
Medida do quadrado	1/2"
Peso	0,80Kg
Dimensões (CxLxA)	218x90x47mm

53328

76,00€

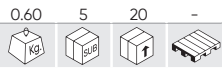

KIT DE PARAFUSO DE SEGURANÇA PARA MERCEDES



Peças	12
Medida do quadrado	1/2"
Peso	0,60Kg
Dimensões (CxLxA)	145x130x45mm

53207

118,00€

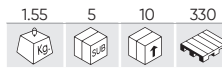

KIT DE PARAFUSO DE SEGURANÇA VW



Peças	23
Medida do quadrado	1/2"
Peso	1,55Kg
Dimensões (CxLxA)	230x16x60mm

52962

42,00€

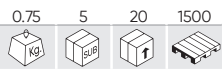

KIT DE CHAVES 3/8" PARA EXTRAÇÃO DE PORCAS



REPOSIÇÕES DISPONÍVEIS

Peças	12
Medida do quadrado	3/8"
Peso	0,75Kg
Dimensões (CxLxA)	163x110x54mm

51998

38,00€

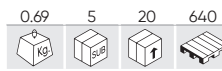

KIT DE CHAVES 3/8" PARA EXTRAÇÃO DE PORCAS



REPOSIÇÕES DISPONÍVEIS

Peças	11
Medida do quadrado	3/8"
Peso	0,68Kg
Dimensões (CxLxA)	165x115x60mm



52153 46,00€

0,93 5 20 360

NEW

KIT DE CHAVES TWIST DE 1/2" PARA EXTRAÇÃO DE FÊMEAS

REPOSIÇÕES DISPONÍVEIS

Peças	6
Medida do quadrado	1/2"
Peso	0,93Kg
Dimensões (CxLxA)	180x135x60mm

54815 49,00€

0,90 5 10 120

NEW

CONJUNTO DE 10 CHAVES DE SOQUETE PARA PARAFUSOS DE BLOQUEIO DE RODA PARA BMW

Peças	10
Peso	0,65Kg
Dimensões (CxLxA)	180x135x56mm

54822 89,00€

1,60 5 10 320

NEW

CONJUNTO DE 10 CHAVES DE SOQUETE PARA PARAFUSOS DE BLOQUEIO DE RODA PARA TESLA

Peças	10
Peso	1,6Kg
Dimensões (CxLxA)	180x135x56mm

54819 91,50€

1,60 5 10 320

NEW

CONJUNTO DE 11 CHAVES PARA PARAFUSO DE BLOQUEIO DE RODA PARA TOYOTA

Peças	11
Peso	1,6Kg
Dimensões (CxLxA)	180x135x56mm

54818 99,50€

1,80 5 10 320

NEW

CONJUNTO DE 14 CHAVES PARA PARAFUSO DE BLOQUEIO DE RODA PARA BMW/MINI

Peças	14
Peso	1,8Kg
Dimensões (CxLxA)	180x135x56mm

54810 143,00€

3,40 - 5 120

NEW

CONJUNTO DE 21 CHAVES PARA PARAFUSO DE BLOQUEIO DE RODA PARA BMW

Peças	21
Peso	2,10Kg
Dimensões (CxLxA)	340x260x90mm

54820 198,00€

3,40 - 5 120

NEW

CONJUNTO DE 21 CHAVES PARA PARAFUSOS DE RODA COM BLOQUEIO OPEL/VAUXHALL (101-120)

Peças	21
Peso	2,5Kg
Dimensões (CxLxA)	280x183x72mm

54821 209,00€

3,40 5 10 120

NEW

CONJUNTO DE 21 CHAVES PARA PARAFUSOS DE RODA COM BLOQUEIO OPEL/VAUXHALL (121-140)

Peças	21
Peso	1,35Kg
Dimensões (CxLxA)	270x170x58mm

54813 143,50€

2,50 - 5 120

NEW

CONJUNTO DE 21 CHAVES PARA PARAFUSO DE BLOQUEIO DE RODA PARA OPEL/VAUXHALL (181-200)

Peças	21
Peso	2,5Kg
Dimensões (CxLxA)	280x180x72mm

54812 143,50€

14.00 - 5 120 **NEW**

CONJUNTO DE 21 CHAVES PARA PARAFUSO DE BLOQUEIO DE RODA PARA VOLKSWAGEN



Peças	21
Peso	2,4Kg
Dimensões (CxLxA)	280x183x72mm

54809 154,00€

3.40 - 5 120 **NEW**

CONJUNTO DE 22 CHAVES PARA PARAFUSO DE BLOQUEIO DE RODA PARA AUDI



Peças	22
Peso	2,80Kg
Dimensões (CxLxA)	340x260x80mm

54317 124,00€

1.45 5 10 120 **NEW**

CONJUNTO DE 22 CHAVES PARA PARAFUSO DE BLOQUEIO DE RODA PARA O GRUPO VAG



Peças	22
Medida do quadrado	1/2"
Peso	1,45Kg
Dimensões (CxLxA)	280x72x180mm

54817 249,00€

2.40 - 5 90 **NEW**

CONJUNTO DE 30 CHAVES PARA PARAFUSO DE BLOQUEIO DE RODA PARA MERCEDES-BENZ



Peças	30
Peso	2,4Kg
Dimensões (CxLxA)	280x183x72mm

54814 169,00€

1.80 - 5 110 **NEW**

CONJUNTO DE 32 CHAVES PARA PARAFUSO DE BLOQUEIO DE RODA PARA MERCEDES-BENZ



Peças	32
Peso	1,8Kg
Dimensões (CxLxA)	280x180x72mm

54823 65,00€

1.20 5 10 320 **NEW**

CONJUNTO DE 5 CHAVES DE SOQUETE PARA PARAFUSOS DE BLOQUEIO DE RODA PARA TESLA 3, S, X



Peças	5
Peso	1,2Kg
Dimensões (CxLxA)	180x135x56mm

54811 64,00€

1.20 5 10 320 **NEW**

CONJUNTO DE 7 CHAVES PARA PARAFUSO DE BLOQUEIO DE RODA PARA OPEL/VAUXHALL



Peças	7
Peso	0,98Kg
Dimensões (CxLxA)	270x170x58mm

54816 49,00€

1.00 5 10 320 **NEW**

CONJUNTO DE 10 CHAVES DE PONTA PARA PARAFUSOS DE BLOQUEIO DE RODA PARA BMW



Peças	10
Peso	0,72Kg
Dimensões (CxLxA)	180x135x56mm

53208 126,00€

0.95 5 20 -

KIT DE PARAFUSO DE SEGURANÇA PARA BMW



Peças	22
Medida do quadrado	1/2"
Peso	0,95Kg
Dimensões (CxLxA)	210x55x140mm

51958

422,00€



DESMULTIPLICADOR DE ROQUETE 3/4" + REDUCTOR DE 1/2"



Peças	6
Medida do quadrado	1/2", 3/4"
Material	Cr
Medidas	13, 19mm
Torque máximo de saída	1000Nm
Relação de transmissão	1:4
Peso	4,34Kg
Dimensões (CxLxA)	375x260x85mm

52056

73,00€



KIT DE 8 CHAVES 1" DESMULTIPLICADOR DE FORÇA



REPOSIÇÕES DISPONÍVEIS

Peças	8
Peso	5,45Kg
Dimensões (CxLxA)	275x240x85mm

51919

89,00€



DESMULTIPLICADOR DE FORÇA COM AUMENTO



Peças	4
Medida do quadrado	1"
Material	40Cr
Medidas	32-33mm
Torque máximo de saída	5800Nm
Relação de transmissão	1:56
Peso	7,75Kg
Dimensões (CxLxA)	380x205x100mm

PARA CAMIÕES/VEÍCULOS

52796

98,00€



DESMULTIPLICADOR DE FORÇA ARTICULADO



Peças	4
Medida do quadrado	1"
Material	40Cr
Medidas	32-33mm
Torque máximo de saída	6000Nm
Relação de transmissão	1:58
Peso	8,88Kg
Dimensões (CxLxA)	395x255x120mm

PARA CAMIÕES/VEÍCULOS



FERRAMENTAS DE SINCRONISMO

301 FIAT/ALFA ROMEO

304 BMW/MINI

310 PSA

311 FORD

315 JAGUAR/LAND ROVER

317 JEEP/CHRYSLER

318 MERCEDES-BENZ

320 RENAULT/DACIA/NISSAN

322 OPEL/VAUXHALL

326 VAG

331 VOLVO

332 OUTRAS

333 FERRAMENTAS ADICIONAIS

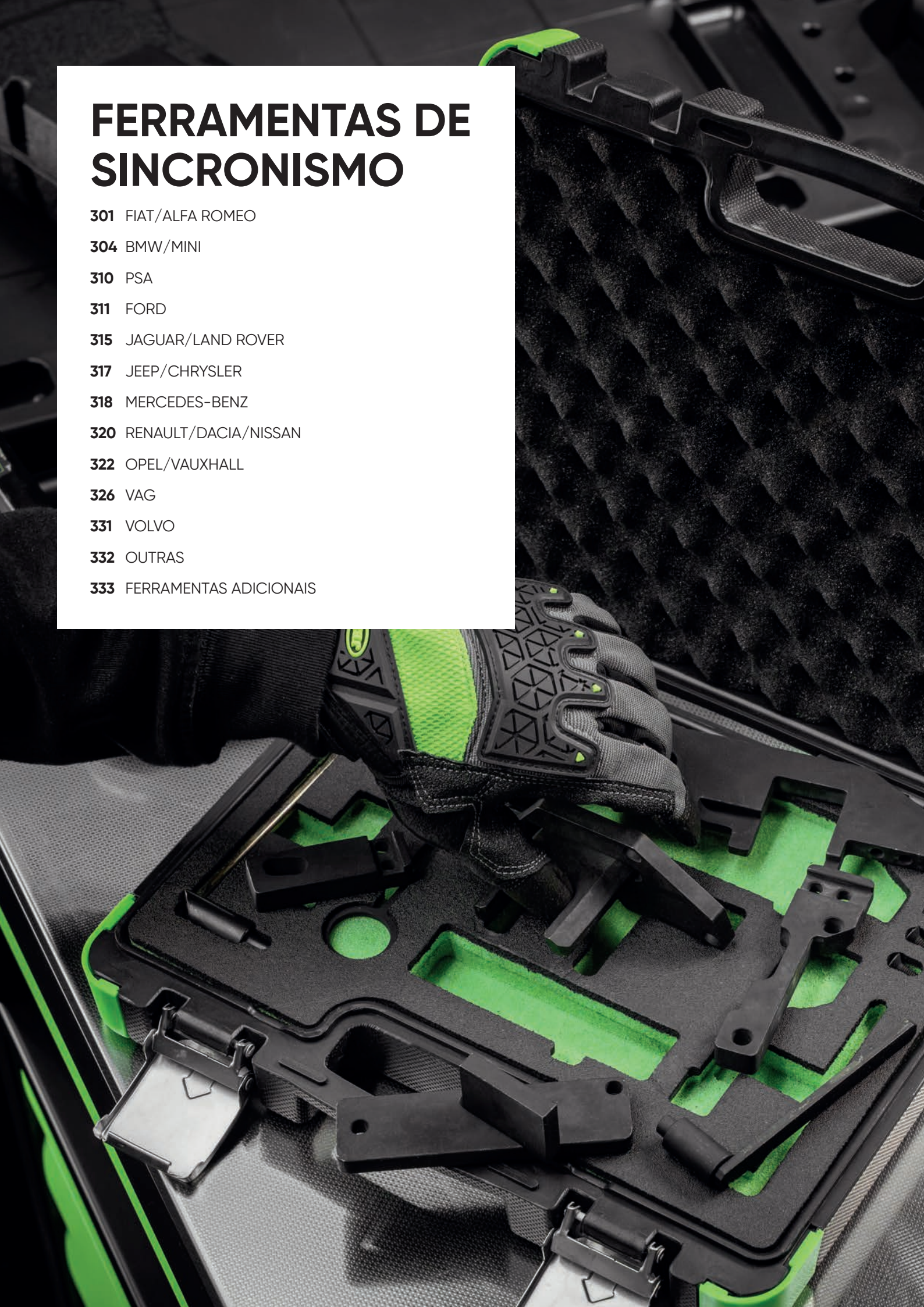



Encontre o kit que precisa em segundos. Rápido e eficiente!



PESQUISA RÁPIDA

Encontre o kit compatível com qualquer veículo



FILTROS AVANÇADOS

Refine a sua pesquisa por marca, motor, OEM ou referência JBM



RESULTADOS PRECISOS

Aceda a todas as informações de que precisa com um único clique

1

INSIRA AS INFORMAÇÕES DO VEÍCULO

Aceda ao nosso site e localize a secção do Timing Tool Finder

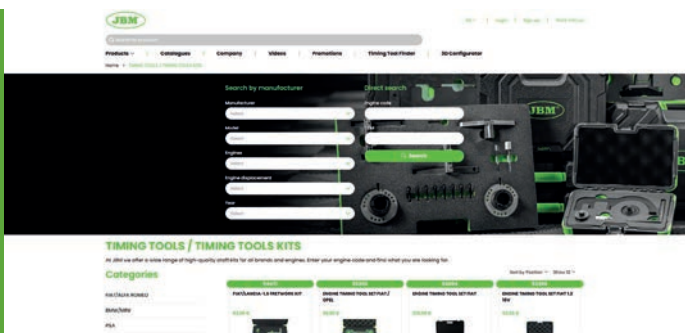

2

Search by manufacturer

Manufacturer:

Model:

Engines:

Engine displacement:

Year:

Direct search

Engine code:

OEM:

3

SELECIONE OS CAMPOS DE PESQUISA

Fabricante, modelo, cilindrada, código do motor e ano

4

OU INSIRA O CÓDIGO DO MOTOR OU O CÓDIGO DE PESQUISA OEM

5

Direct search

Engine code:

OEM:



6

COMPARE OS RESULTADOS E ENCONTRE O SEU KIT DE FERRAMENTAS DE SINCRONISMO



Catálogo Exclusivo de Kits de Calado

Encontre toda a informação de que precisa num só lugar:

- ✓ Descrição detalhada de estojos e módulos
- ✓ Aplicações de cada ferramenta
- ✓ Códigos de motor e OEM compatíveis

Solicite já o seu catálogo.
A JBM imprime-o e envia-lho sem complicações.



54471

67,00€

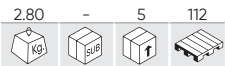

KIT DE RETRABALHO FIAT/LANCIA-1.6



INFORMAÇÕES ADICIONAIS

54743

82,00€

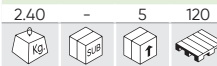

NEW

FERRAMENTA DE SINCRONIZAÇÃO PARA FIAT HÍBRIDO 1.0L FIRE-FLY



INFORMAÇÕES ADICIONAIS

53303

94,00€

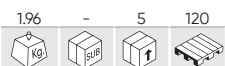

KIT DE BLOQUEIO FIAT / OPEL



INFORMAÇÕES ADICIONAIS

54745

152,00€



NEW

KIT DE FERRAMENTAS DE SINCRONIZAÇÃO PARA FIAT/JEEP 1.0L/1.3



INFORMAÇÕES ADICIONAIS



53304

293,00€

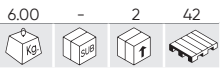

KIT DE BLOQUEIO FIAT

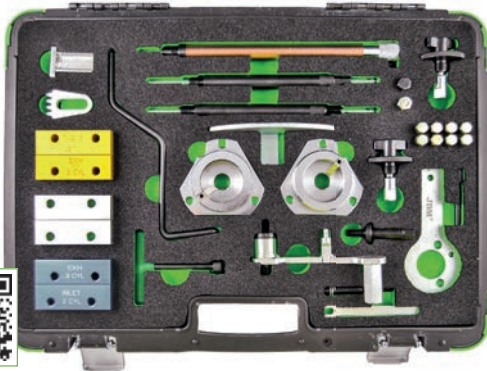

INFORMAÇÕES ADICIONAIS

53306

56,00€



KIT DE BLOQUEIO FIAT 1.2 16V



INFORMAÇÕES ADICIONAIS

53308

58,00€

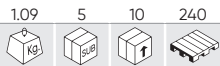

KIT DE BLOQUEIO ALFA ROMEO



INFORMAÇÕES ADICIONAIS

53309

300,00€



KIT DE BLOQUEIO ALFA/FIAT/LANCIA 1.4, 1.6, 1.8, 2.0 16V, 2.0 20V



INFORMAÇÕES ADICIONAIS

53310

523,00€

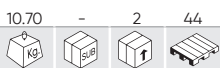

KIT DE BLOQUEIO FIAT/ALFA/LANCIA



INFORMAÇÕES ADICIONAIS

53312

127,00€



KIT DE BLOQUEIO FIAT/ALFA/FORD



INFORMAÇÕES ADICIONAIS

53319

19,00€

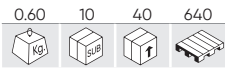

KIT DE BLOQUEIO FIAT IVECO 2.3, 3.0 JTD

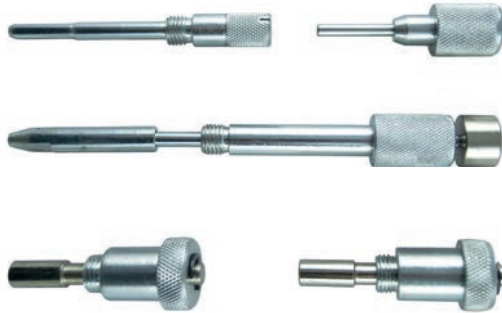

INFORMAÇÕES ADICIONAIS

54202

72,00€

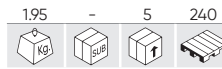

KIT DE BLOQUEIO DE DISTRIBUIÇÃO PARA FIAT/ALFA ROMEO/LANCIA



INFORMAÇÕES ADICIONAIS

54203

96,00€

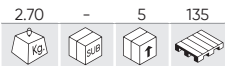

KIT DE BLOQUEIO DE DISTRIBUIÇÃO PARA ALFA ROMEO/LANCIA 1.8 TBI



INFORMAÇÕES ADICIONAIS

54211

78,00€



KIT DE BLOQUEIO DE DISTRIBUIÇÃO PARA FIAT/FORD/OPEL/SUZUKI 1.3L



INFORMAÇÕES ADICIONAIS

54212

42,00€

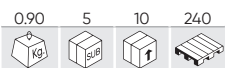

KIT DE BLOQUEIO DE DISTRIBUIÇÃO PARA FIAT/LANCIA 1,4 12V



INFORMAÇÕES ADICIONAIS

54215

60,00€

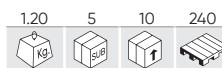

KIT DE BLOQUEIO DE DISTRIBUIÇÃO PARA ALFA ROMEO/FIAT 1.4 MULTIAIR



INFORMAÇÕES ADICIONAIS



54216

52,00€

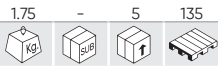

KIT DE BLOQUEIO DE DISTRIBUIÇÃO PARA FIAT/OPEL/ALFA 1.9, 2.4L 16V



INFORMAÇÕES ADICIONAIS

54430

36,00€

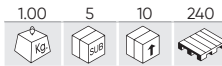

KIT DE BLOQUEIO ALFA ROMEO/FIAT/LANCIA 0.9 TWIN AIR



INFORMAÇÕES ADICIONAIS

54796

239,00€

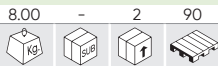

NEW

CONJUNTO DE AFINAÇÃO DO MOTOR BMW B38/B46/B48



INFORMAÇÕES ADICIONAIS

54862

61,00€

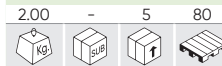

NEW

KIT DE FERRAMENTAS DE AJUSTE DO MOTOR BMW/MINI 1.6



INFORMAÇÕES ADICIONAIS

54444

141,00€



KIT DE BLOCO DE MOTOR A GASOLINA BMW M3 -S54

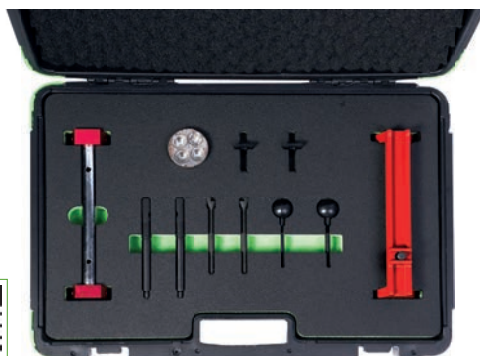

INFORMAÇÕES ADICIONAIS

54445

111,00€



KIT DE BLOQUEIO DE MOTOR A GASOLINA BMW M3 S65



INFORMAÇÕES ADICIONAIS

54441 174,00€

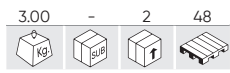

CONJUNTO DE AFINAÇÃO DO MOTOR BMW N47/N57



INFORMAÇÕES ADICIONAIS



53259 102,00€

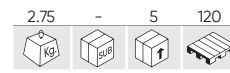

KIT DE BLOQUEIO BMW N42, N46 1.8, 2.0 CADEIA



INFORMAÇÕES ADICIONAIS



53260 177,00€

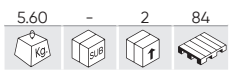

KIT DE BLOQUEIO BMW N43 1,6/2,0 CADEIA



INFORMAÇÕES ADICIONAIS

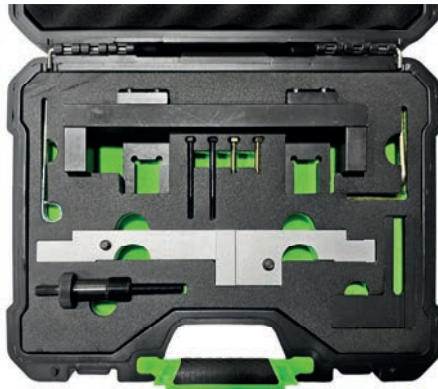

53261 225,00€



KIT DE BLOQUEIO BMW N42, N46 1.8, 2.0



INFORMAÇÕES ADICIONAIS



53262 264,00€

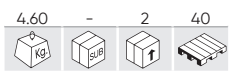

KIT DE BLOQUEIO EIXO DE COMANDO BMW M52TU, M54, M56 DUPLO VÃOS



INFORMAÇÕES ADICIONAIS



53263 60,00€



KIT BLOQUEIO EIXO DE COMANDO BMW M47 LAND ROVER TD4,TD6



INFORMAÇÕES ADICIONAIS



53264

151,00€

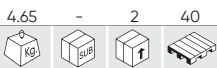

KIT DE BLOQUEIO BMW N62, N73



INFORMAÇÕES ADICIONAIS



53265

205,00€

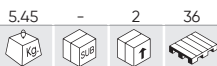

KIT DE BLOQUEIO BMW DIESEL M47, M57, M41, M51



INFORMAÇÕES ADICIONAIS

53266

236,00€



KIT DE BLOQUEIO BMW M42, M43, M50, M51, M52

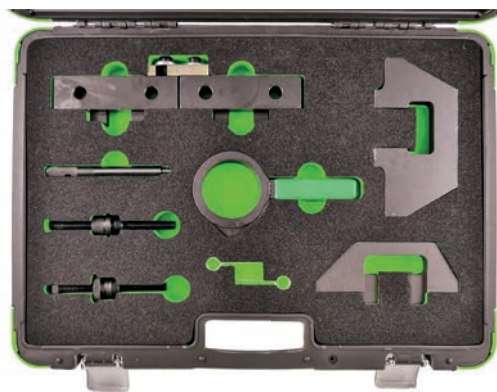

INFORMAÇÕES ADICIONAIS

53267

291,00€



KIT DE BLOQUEIO BMW BMW M40, M43, M42, M44, M52, M54, M56

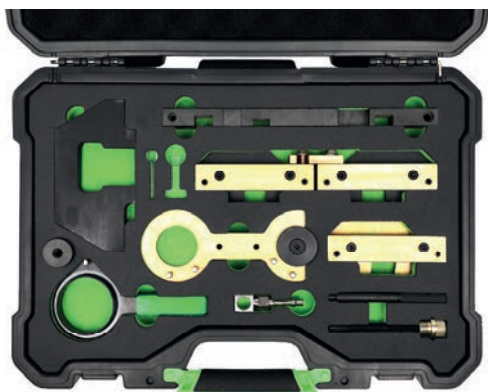

INFORMAÇÕES ADICIONAIS

54293

19,00€



CONTRA-MANCAL DA CAMBOTA PARA BMW



INFORMAÇÕES ADICIONAIS

53269 50,00€

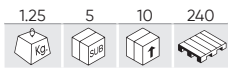

KIT DE BLOQUEIO BMW N47, N47S, N57 (PARA UTILIZAÇÃO COM 54293)



INFORMAÇÕES ADICIONAIS



54219 63,00€



KIT DE BLOQUEIO DE DISTRIBUIÇÃO PARA BMW/MINI/CITROËN/PEUGEOT



INFORMAÇÕES ADICIONAIS



54222 62,00€

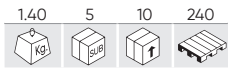

KIT DE DISTRIBUIÇÃO PARA MINI 1.6



INFORMAÇÕES ADICIONAIS



54227 129,00€

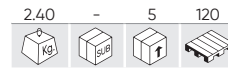

KIT DE DISTRIBUIÇÃO PARA BMW/MINI N13, N18



INFORMAÇÕES ADICIONAIS



54228 187,00€

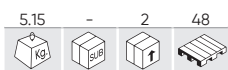

KIT DE BLOQUEIO DE DISTRIBUIÇÃO PARA BMW/MINI 1.2, 1.5, 2.0, 3.0



INFORMAÇÕES ADICIONAIS

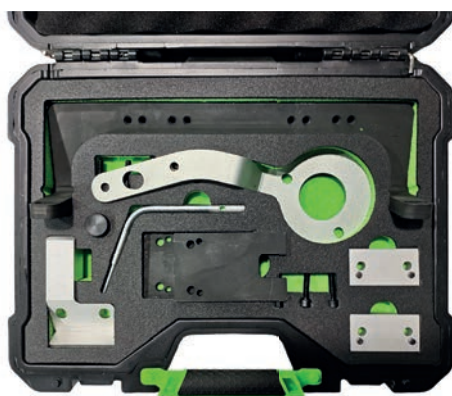

54206 119,00€

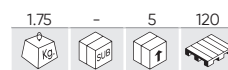

KIT DE BLOQUEIO DE DISTRIBUIÇÃO PARA BMW/MINI 1.5, 2.0L



INFORMAÇÕES ADICIONAIS

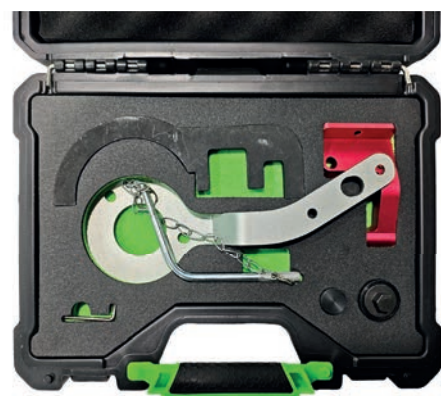

54398

44,00€

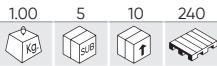

JOGO DE BLOQUEIO DE VOLANTE / POLIA DA CAMBOTA PARA BMW/MINI



INFORMAÇÕES ADICIONAIS

54399

60,00€



KIT DE BLOQUEIO BMW/RANGE ROVER/OPEL 2.5D



INFORMAÇÕES ADICIONAIS

54400

149,00€

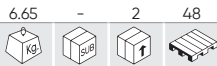

KIT DE BLOQUEIO BMW N20, N26



INFORMAÇÕES ADICIONAIS

54402

212,00€

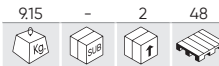

KIT DE BLOQUEIO BMW N51, N52, N53, N54, N55

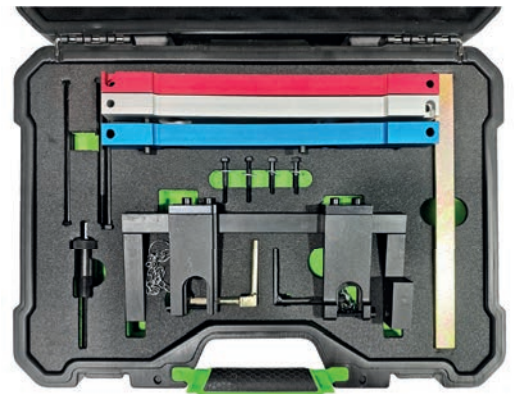

INFORMAÇÕES ADICIONAIS

54401

60,00€



KIT DE BLOQUEIO BMW/MINI N13, N18



INFORMAÇÕES ADICIONAIS

54403

237,00€



KIT DE BLOQUEIO BMW / LAND ROVER



INFORMAÇÕES ADICIONAIS

54405

117,00€

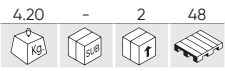

KIT DE BLOQUEIO BMW N63, N74



INFORMAÇÕES ADICIONAIS



54404

138,00€



KIT DE BLOQUEIO BMW N62, N73



INFORMAÇÕES ADICIONAIS



54324

12,00€

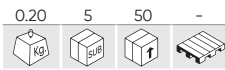

INDICADOR DE DESGASTE DA CORRENTE DE DISTRIBUIÇÃO MINI



INFORMAÇÕES ADICIONAIS



54406

77,00€

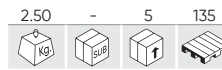

BLOQUEADOR DO VOLANTE DO MOTOR BMW/MINI



INFORMAÇÕES ADICIONAIS



54442

35,00€

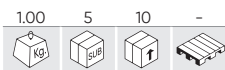

ALINHADOR DA BOMBA DE ÓLEO E EIXO DE EQUILÍBRIO BMW



INFORMAÇÕES ADICIONAIS



53268

92,00€

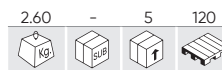

KIT DE BLOQUEIO BMW/MINI/PSA 1.4, 1.6



INFORMAÇÕES ADICIONAIS





54722

37,00€

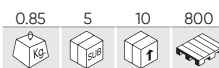

SINCRONIZAÇÃO DO MOTOR E KIT TENSOR - PARA FORD E PSA DIESEL

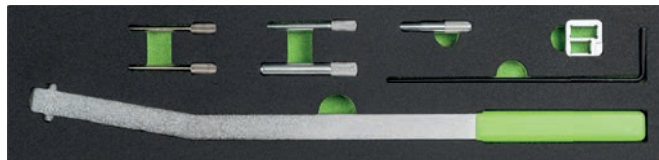

INFORMAÇÕES ADICIONAIS

54739

62,00€



FERRAMENTA DE BLOQUEIO DA TEMPORIZAÇÃO DA ÁRVORE DE CAMES DO MOTOR PSA PEUGEOT CITROËN



INFORMAÇÕES ADICIONAIS

53313

146,00€



KIT DE BLOQUEIO CITROEN/PEUGEOT



INFORMAÇÕES ADICIONAIS

53314

103,00€



KIT DE BLOQUEIO CITROEN/PEUGEOT 1.8, 2.0



INFORMAÇÕES ADICIONAIS

53876

64,00€



KIT DE BLOQUEIO PSA 1.0, 1.2 VTI



INFORMAÇÕES ADICIONAIS

54288

72,50€

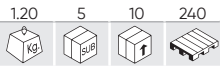

SET DISTRIBUIÇÃO PE PSA 1.2 GDI PURETECH



INFORMAÇÕES ADICIONAIS



54323

119,00€

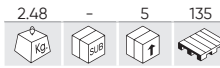

KIT DE BLOQUEIO PSA 1.0, 1.2 VTI, 1.2 GDI PURETECH



REPOSIÇÕES DISPONÍVEIS



INFORMAÇÕES ADICIONAIS



16400

7,00€

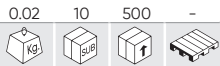

CALIBRAGEM DE VERIFICAÇÃO DA CORREIA DENTADA PSA (REF.54288)



INFORMAÇÕES ADICIONAIS



54433

19,00€

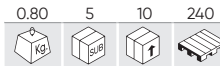

KIT DE BLOQUEIO PSA 1.0, 1.1, 1.2, 1.4, 1.6, 2.0



INFORMAÇÕES ADICIONAIS



54432

46,00€

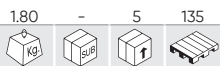

KIT DE BLOQUEIO MERCEDES PSA 2.7, 3.0 HDI



INFORMAÇÕES ADICIONAIS



54213

21,00€

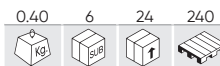

KIT DE BLOQUEIO DE DISTRIBUIÇÃO PARA ROVER/PEUGEOT/FORD/VOLVO 2.0, 2.2L D



INFORMAÇÕES ADICIONAIS



54462

54,00€

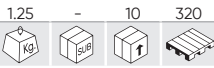

ALINHADOR DO EIXO DE BALANCEAMENTO - FORD 2.2 DIESEL



INFORMAÇÕES ADICIONAIS

54891

40,00€

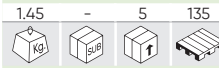

NEW

KIT DE SINCRONISMO PARA MOTORES FORD/PEUGEOT/CITROËN/JAGUAR/LAND ROVER/FIAT 2.2TDCI



INFORMAÇÕES ADICIONAIS

54947

73,50€

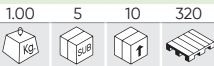

NEW

KIT DE FERRAMENTAS DE SINCRONIZAÇÃO DE ÁRVORE DE CAMES PARA FORD 1.0 CORREIA HÚMIDA



INFORMAÇÕES ADICIONAIS

54950

102,50€



NEW

KIT DE SINCRONIZAÇÃO PARA MOTORES FORD 1.0 TURBO



INFORMAÇÕES ADICIONAIS

54594

104,00€

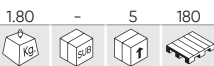

KIT DE CORREIA DE DISTRIBUIÇÃO FORD GASOLINA 1.5 ECOBOOST



INFORMAÇÕES ADICIONAIS

54592

96,00€



KIT DE CORREIA DE DISTRIBUIÇÃO FORD GASOLINA ECOBOOST



INFORMAÇÕES ADICIONAIS

53293 134,00€

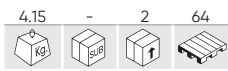

KIT DE BLOQUEIO FORD



INFORMAÇÕES ADICIONAIS



53295 81,00€

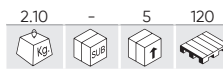

KIT DE BLOQUEIO FORD 1,8TDDI, TDCI



INFORMAÇÕES ADICIONAIS

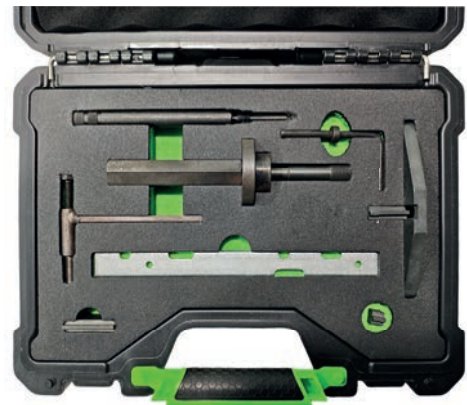

53296 63,00€

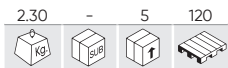

KIT DE BLOQUEIO PARA BOMBA DE INJEÇÃO FORD/JAGUAR DURATORQ



INFORMAÇÕES ADICIONAIS

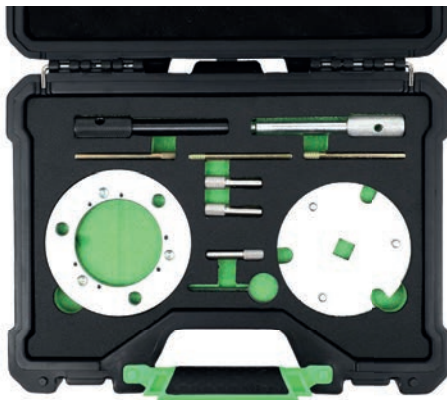

53294 125,00€

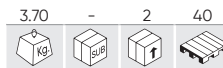

KIT DE BLOQUEIO FORD MAZDA



INFORMAÇÕES ADICIONAIS



54421 55,00€

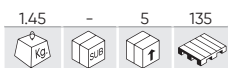

INSTALADOR DE CORREIA AUXILIAR FORD/VOLVO 1.4 1.6



INFORMAÇÕES ADICIONAIS



54420 108,00€

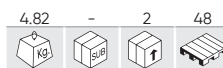

CONJUNTO DE AJUSTE DE COMBUSTÍVEL – FORD/VOLVO 2.5 (EURO 4)



INFORMAÇÕES ADICIONAIS



54424

68,00€

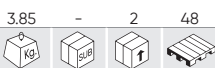

KIT DE BLOQUEIO FORD 2.0 ECOBOOST



INFORMAÇÕES ADICIONAIS

53324

14,00€

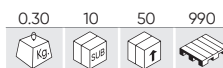

KIT DE BLOQUEIO FORD / MAZDA / VOLVO

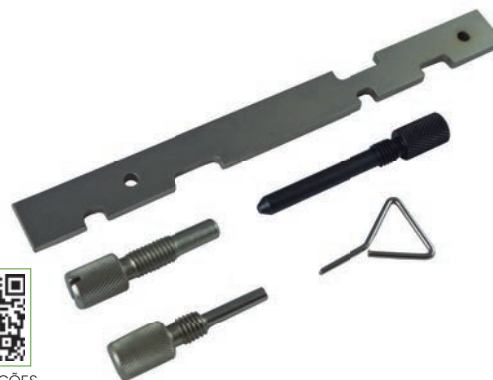

INFORMAÇÕES ADICIONAIS

53653

207,00€



KIT DE BLOQUEIO FORD

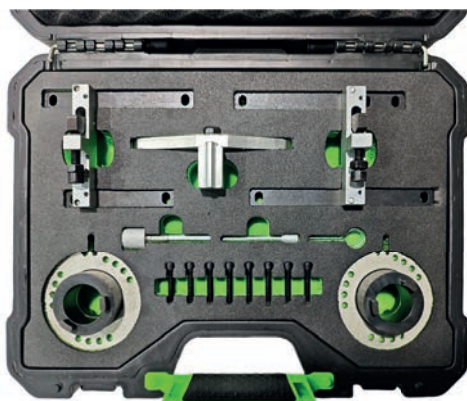

INFORMAÇÕES ADICIONAIS

54201

40,00€

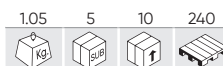

CONJUNTO DE FERRAMENTAS DE REGULAÇÃO DO MOTOR FORD



INFORMAÇÕES ADICIONAIS

54204

124,00€

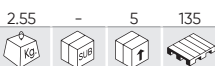

KIT DE BLOQUEIO DE DISTRIBUIÇÃO PARA FORD 2.0 ECOBLUE

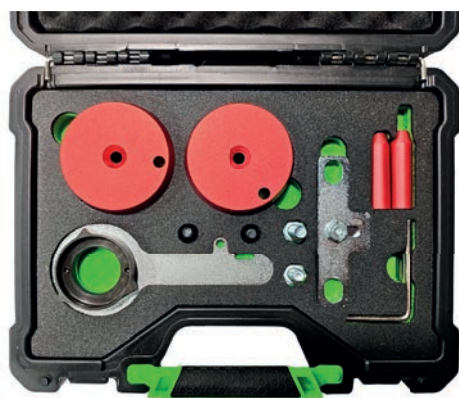

INFORMAÇÕES ADICIONAIS

54208

80,00€



KIT DE BLOQUEIO DE DISTRIBUIÇÃO PARA FORD 2.0 ECO BOOST SCTI, TI-VCT



INFORMAÇÕES ADICIONAIS

54209

32,00€

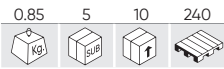

KIT DE BLOQUEIO DE DISTRIBUIÇÃO PARA FORD/MAZDA 2.2, 3.2 TDCI



INFORMAÇÕES ADICIONAIS



54223

157,00€



FERRAMENTA DE BLOQUEIO DE ÁRVORE DE CAMAS PARA FORD 1.5T



INFORMAÇÕES ADICIONAIS

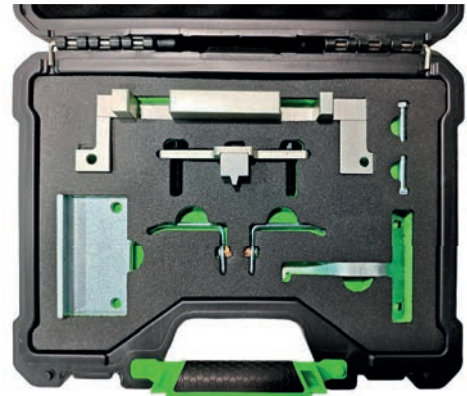

54224

68,00€

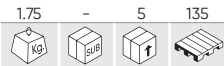

KIT DE INSTALAÇÃO/REMOÇÃO DE BOMBA DE INJEÇÃO PARA FORD 2.0



INFORMAÇÕES ADICIONAIS



54260

277,00€



KIT DE MULTIPLICADOR DE FORÇA 5:1 PARA MOTORES FORD ECOBOOST



INFORMAÇÕES ADICIONAIS

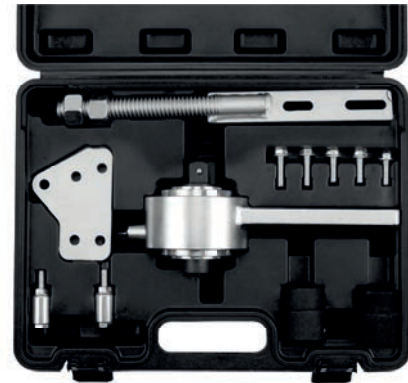

54463

140,00€

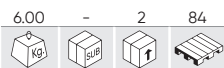

KIT DE CALÇOS DIESEL-JAGUAR/LAND ROVER 2.0D



INFORMAÇÕES ADICIONAIS



54464

160,00€

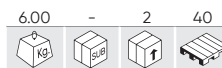

KIT DE REBARBAÇÃO DE GASOLINA -JAGUAR/ LAND ROVER



INFORMAÇÕES ADICIONAIS



54465

204,00€



KIT DE BLOQUEIO JAGUAR/LAND ROVER-3.0/5.0

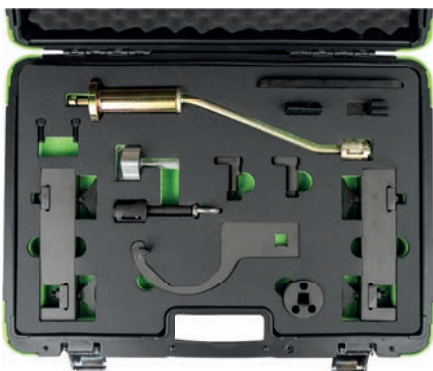

INFORMAÇÕES ADICIONAIS

53297

48,00€

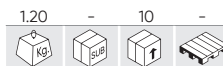

KIT DE BLOQUEIO JAGUAR/LAND ROVER



INFORMAÇÕES ADICIONAIS

54298

96,00€



KIT DE BLOQUEIO LAND ROVER



INFORMAÇÕES ADICIONAIS

54422

147,00€

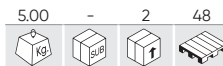

KIT DE AJUSTE DO EIXO DE EQUILÍBRIO JAGUAR/LAND ROVER 2.0D



INFORMAÇÕES ADICIONAIS

54423

114,00€

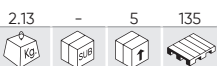

KIT DE BLOQUEIO LAND ROVER 3.6D



INFORMAÇÕES ADICIONAIS

54425

131,00€



KIT DE BLOQUEIO LAND ROVER FREELANDER V6/ROVER KV6 2.0L, 2.5L



INFORMAÇÕES ADICIONAIS

54426

73,00€

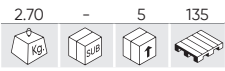

KIT DE BLOQUEIO JAGUAR/LAND ROVER 3.2, 3.5, 4.0, 4.2, 4.4



INFORMAÇÕES ADICIONAIS



54427

119,00€

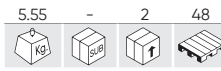

FERRAMENTA DE BLOQUEIO DA POLIA DA CAMBOTA JAGUAR/LAND ROVER 4.0, 4.2, 4.4



INFORMAÇÕES ADICIONAIS



54846

239,00€

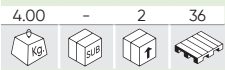

NEW

KIT DE SINCRONIZAÇÃO PARA JAGUAR/LAND ROVER 2.0L (DIESEL)



INFORMAÇÕES ADICIONAIS



54744

61,00€



NEW

FERRAMENTA DE CRONOMETRAGEM PARA FIAT/JEEP 1.0 E 1.3L



INFORMAÇÕES ADICIONAIS



53270

74,00€

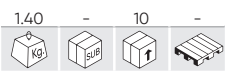

KIT DE BLOQUEIO MERCEDES/CHRYSLER/JEEP



INFORMAÇÕES ADICIONAIS



54207

41,00€

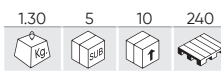

KIT DE BLOQUEIO DE DISTRIBUIÇÃO PARA CHRYSLER/JEEP 2.5 LDV CRD



INFORMAÇÕES ADICIONAIS



54429

58,00€



KIT DE BLOQUEIO CHRYSLER/JEEP 3.0D



54428

33,00€



KIT DE BLOQUEIO CHRYSLER/JEEP 2.8 CRD



54738

167,00€



KIT DE BLOQUEIO DA ÁRVORE DE CAMES PARA MOTORES DIESEL MERCEDES



53273

79,00€



KIT DE BLOQUEIO MERCEDES M276, M157, M278



53272

205,00€

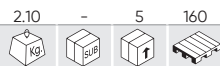

SET DE DISTRIBUIÇÃO PE MERCEDES AMG 156



53271

239,00€



KIT DE BLOQUEIO MERCEDES BENZ M271



54414

97,50€

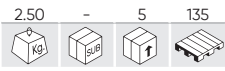

KIT DE BLOQUEIO MERCEDES M651



INFORMAÇÕES ADICIONAIS

54415

63,00€

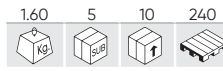

KIT DE BLOQUEIO MERCEDES M651



INFORMAÇÕES ADICIONAIS

54416

33,00€

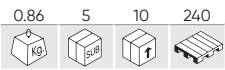

KIT DE BLOQUEIO MERCEDES M642



INFORMAÇÕES ADICIONAIS

54949

482,50€



NEW

KIT DE SINCRONIZAÇÃO MERCEDES M176/
M177/M178



INFORMAÇÕES ADICIONAIS

54417

161,00€

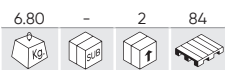

KIT DE BLOQUEIO MERCEDES M133, M270,
M274

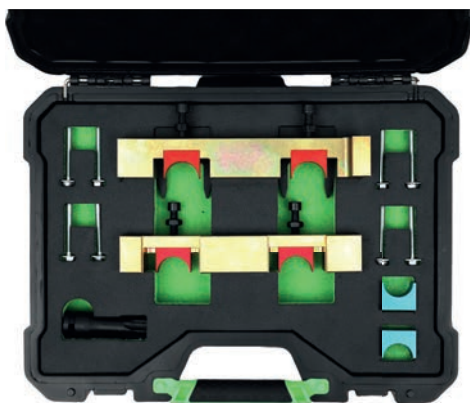

INFORMAÇÕES ADICIONAIS

54418

39,00€



KIT DE BLOQUEIO MERCEDES M112, M113



INFORMAÇÕES ADICIONAIS



54899

92,00€

2.50 - 5 80



NEW

KIT DE BLOQUEIO DE DISTRIBUIÇÃO PARA RENAULT/OPEL/NISSAN 2.0 BLUE DCI M9R



INFORMAÇÕES ADICIONAIS

53290

54,00€

1.90 - 5 120



KIT DE BLOQUEIO RENAULT/VOLVO 16V, 20V



INFORMAÇÕES ADICIONAIS

51488

16,00€

0.25 5 50 1200



BLOQUEADOR DE CAMBOTA E ÁRVORE DECAMES RENAULT/NISSAN/DACIA/SUZUKI



INFORMAÇÕES ADICIONAIS

53311

97,00€

2.55 - 5 120



KIT DE BLOQUEIO RENAULT/NISSAN/OPEL/VAUXHALL 1.6, 2.0, 2.3 DCI



INFORMAÇÕES ADICIONAIS

54593

127,00€

4.00 - 2 48



KIT DE CORREIA DE DISTRIBUIÇÃO RENAULT 1.4, 1.6, 1.8, 2.0 16V TWIN



INFORMAÇÕES ADICIONAIS

53289

48,00€

1.50 5 10 250



KIT DE BLOQUEIO RENAULT 1.4, 1.6, 1.8, 2.0 16V



INFORMAÇÕES ADICIONAIS

53523

94,00€

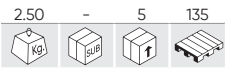

KIT DE BLOQUEIO DE MOTORES A DIESEL
RENAULT/NISSAN/OPEL 1.6, 2.0, 2.3 DCI



INFORMAÇÕES
ADICIONAIS



53292

122,00€



KIT DE BLOQUEIO RENAULT/OPEL 2.2, 2.5
TDI DCI



INFORMAÇÕES
ADICIONAIS



53291

72,00€

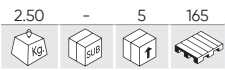

KIT DE BLOQUEIO RENAULT



INFORMAÇÕES
ADICIONAIS



54210

89,00€



KIT DE BLOQUEIO DA ÁRVORE DE CAMES
PARA RENAULT 1,8, 2,0 16 V



INFORMAÇÕES
ADICIONAIS



54225

140,00€

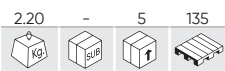

KIT DE BLOQUEIO DE VOLANTE / POLIA DA
CAMBOTA PARA RENAULT/NISSAN



INFORMAÇÕES
ADICIONAIS

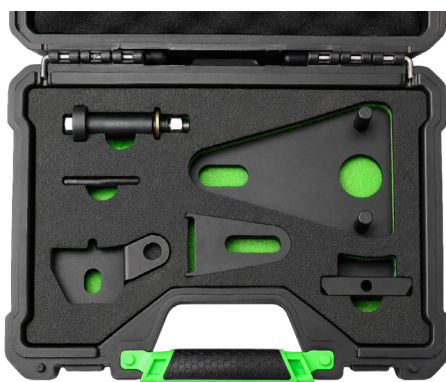

54438

42,00€



KIT DE BLOQUEIO RENAULT/NISSAN 3.0DCI



INFORMAÇÕES
ADICIONAIS



54289

40,00€

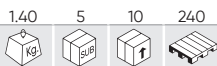

KIT DE BLOQUEIO DO VOLANTE DE INÉRCIA PARA MERCEDES/RENAULT/DACIA/NISSAN



INFORMAÇÕES ADICIONAIS

54477

62,00€



FERRAMENTA DE CRONOMETRAGEM DIESEL OPEL/CHEVROLET SUZUKI 1.9 E 2.5 DTI - CDTI



INFORMAÇÕES ADICIONAIS

54439

35,00€

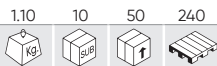

BLOQUEIO DA POLIA DA EIXO DE MANIVELAS RENAULT/DACIA 0,9, 1,0, 1,2, 1,6 TCE



INFORMAÇÕES ADICIONAIS

53299

306,00€



KIT DE BLOQUEIO OPEL/VAUXHALL



INFORMAÇÕES ADICIONAIS



54831

82,00€



NEW

KIT DE SINCRONIZAÇÃO PARA OPEL/VAUXHALL 1.0, 1.4



INFORMAÇÕES ADICIONAIS

54893 105,00€

9,00 - 5 80

NEW

KIT DE SINCRONISMO PARA MOTORES OPEL/VAUXHALL 2.0CDTI - CORREIA



INFORMAÇÕES ADICIONAIS

53300 44,00€

1,25 - 10 270

KIT DE BLOQUEIO OPEL/VAUXHALL/CHEVROLET 2,0CDI



INFORMAÇÕES ADICIONAIS

53301 47,00€

1,15 5 10 240

KIT DE BLOQUEIO SUZUKI/OPEL 1.0, 1.2, 1.4



INFORMAÇÕES ADICIONAIS

53302 47,00€

1,10 5 10 240

KIT DE BLOQUEIO FIAT/ALFA ROMEO/VAUXHALL/OPEL/SAAB JTD



INFORMAÇÕES ADICIONAIS

53305 143,00€

3,60 - 2 42

KIT DE BLOQUEIO SAAB/OPEL/VAUXHALL



INFORMAÇÕES ADICIONAIS

53307 41,00€

0,98 5 10 240

KIT DE BLOQUEIO ALFA/OPEL/VAUXHALL 1.6, 1.8 16V



INFORMAÇÕES ADICIONAIS



53316

36,00€

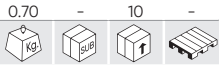

FERRAMENTA DE FIXAÇÃO DA ÁRVORE DE CAMES FIAT/OPEL/VAUXHALL 2.2 16V ACIONAMENTO POR CORRENTE



INFORMAÇÕES ADICIONAIS

53317

36,00€



RETENTOR DA BOMBA DE LÍQUIDO DE REFRIGERAÇÃO OPEL/VAUXHALL 2.2



INFORMAÇÕES ADICIONAIS

53651

91,00€

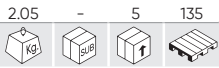

KIT DE BLOQUEIO AUDI OPEL/VAUXHALL 1.0, 1.2, 1.4 TURBO

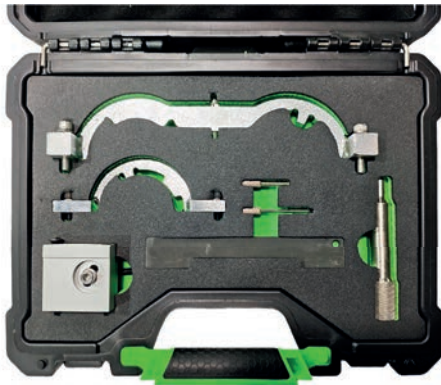

INFORMAÇÕES ADICIONAIS

53452

28,00€



KIT DE BLOQUEIO OPEL/FORD/FIAT/ ALFA ROMEO/LANCIA/SUZUKI



INFORMAÇÕES ADICIONAIS

54437

116,00€

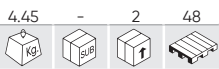

KIT DE BLOQUEIO OPEL/CHEVROLET/SAAB 2.0, 2.4



INFORMAÇÕES ADICIONAIS

54435

16,00€

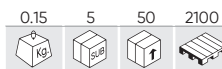

KIT DE BLOQUEIO OPEL/CHEVROLET/SAAB 1.4, 1.6, 1.8 ECOTEC



INFORMAÇÕES ADICIONAIS

54205

52,00€

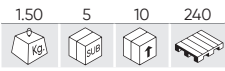

KIT DE BLOQUEIO DE DISTRIBUIÇÃO PARA VAUXHALL/OPEL 1.6 CDTI



INFORMAÇÕES ADICIONAIS



54214

101,00€



SET DE DISTRIBUIÇÃO PE OPEL/ISUZU 1.6D, 1.7D



INFORMAÇÕES ADICIONAIS

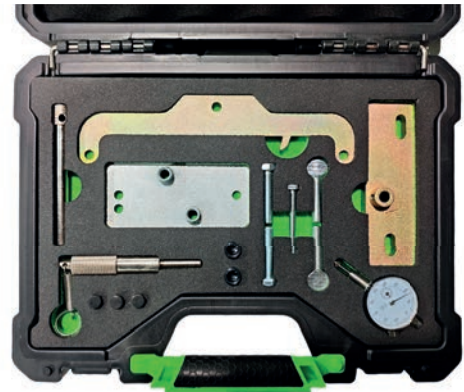

54217

110,00€

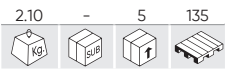

KIT DE BLOQUEIO DE DISTRIBUIÇÃO PARA VAUXHALL/OPEL/SAAB 2.0, 2.2 DTI



INFORMAÇÕES ADICIONAIS



54221

117,00€



KIT DE BLOQUEIO DE DISTRIBUIÇÃO PARA VAUXHALL/OPEL 1.3 CDTI



INFORMAÇÕES ADICIONAIS



54434

51,00€

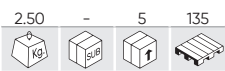

KIT DE BLOQUEIO OPEL 1.0, 1.4, 1.5



INFORMAÇÕES ADICIONAIS

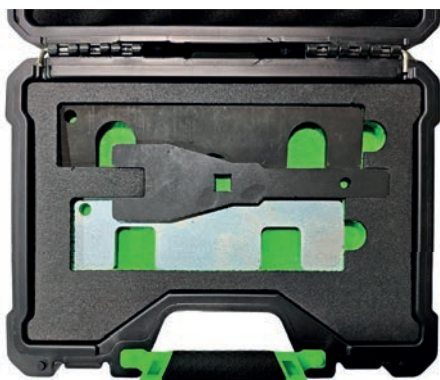

54436

131,00€



KIT DE BLOQUEIO OPEL 1.6 SIDI



INFORMAÇÕES ADICIONAIS



54746

306,00€

6.00 - 2 36



NEW

FERRAMENTA DE TEMPORIZAÇÃO PARA VAG 1.0/1.2/1.4/1.5/1.6 TSI GASOLINA

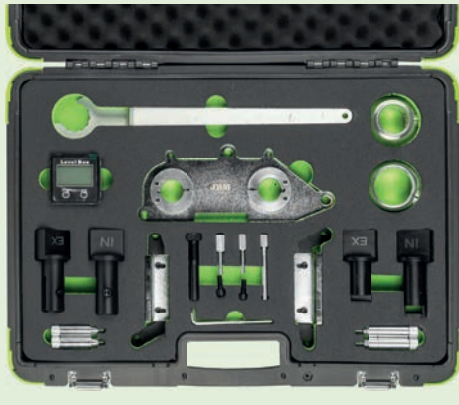

INFORMAÇÕES ADICIONAIS

51489

13,00€

0.35 10 40 800



FERRAMENTA DE BLOQUEIO DA ÁRVORE DE CAMES VAG 1.4, 1.6



INFORMAÇÕES ADICIONAIS

52271

18,00€

0.45 10 40 960



KIT DE BLOQUEIO DE DISTRIBUIÇÃO VAG



INFORMAÇÕES ADICIONAIS

54454

192,00€

6.25 - 2 40



KIT DE BLOQUEIO AUDI 3.0 FSI/TFSI/RS



INFORMAÇÕES ADICIONAIS

55008

109,00€

4.65 - 2 42



NEW

KIT DE FERRAMENTAS DE SINCRONISMO PARA VAG 1.8 2.0TSI TFSI



INFORMAÇÕES ADICIONAIS

53278

151,00€

4.75 - 2 48



KIT DE BLOQUEIO AUDI 2.8, 3.2 FSI, 3.0 TFSI



INFORMAÇÕES ADICIONAIS

53274

33,00€

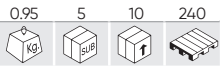

KIT DE BLOQUEIO VOLKSWAGEN/SEAT/
SKODA 1,2L



REPOSIÇÕES
DISPONÍVEIS



INFORMAÇÕES
ADICIONAIS



53275

38,00€

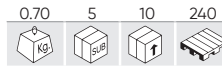

KIT DE BLOQUEIO VAG



INFORMAÇÕES
ADICIONAIS



53276

168,00€

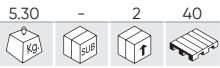

KIT DE BLOQUEIO AUDI/VW/SKODA



INFORMAÇÕES
ADICIONAIS



53279

102,00€

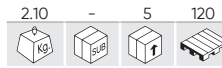

KIT DE BLOQUEIO VW/AUDI 1.8, 2.0, TSI, TFSI



INFORMAÇÕES
ADICIONAIS



53277

48,00€

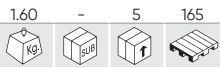

JOGO DE CHAVES PARA TENSOR DA
CORREIA DE DISTRIBUIÇÃO VW E AUDI



INFORMAÇÕES
ADICIONAIS



53280

118,00€

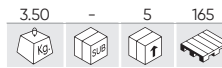

KIT DE FERRAMENTAS DE SINCRONIZAÇÃO
VAG 3.0 V6



INFORMAÇÕES
ADICIONAIS



53281

58,00€

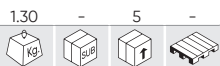

SET DE ALINHAMENTO EIXO DE COMANDO VW/AUDI



INFORMAÇÕES ADICIONAIS

53282

51,00€



KIT DE BLOQUEIO VAG 1.2, 1.4, 1.6



INFORMAÇÕES ADICIONAIS

53283

97,00€

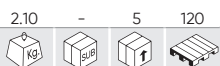

KIT DE BLOQUEIO GRUPO VAG 2.7, 3.0 TDI



INFORMAÇÕES ADICIONAIS

53284

322,00€



KIT DE BLOQUEIO GRUPO VAG 2.5 TDI



INFORMAÇÕES ADICIONAIS

53285

59,00€

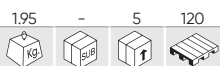

KIT DE BLOQUEIO VAG 2.4, 2.5, SDI, TDI



INFORMAÇÕES ADICIONAIS

53288

76,00€



KIT DE BLOQUEIO VAG 1.6, 2.0 TDI COMMON RAIL



REPOSIÇÕES DISPONÍVEIS



INFORMAÇÕES ADICIONAIS

53320

13,00€

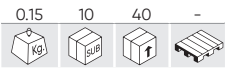

CONJUNTO DE FERRAMENTAS DE TEMPO PARA VAG



INFORMAÇÕES ADICIONAIS

53326

17,00€



KIT DE BLOQUEIO VW/AUDI



INFORMAÇÕES ADICIONAIS

53327

12,00€

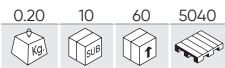

KIT DE BLOQUEIO VAG 1.2



INFORMAÇÕES ADICIONAIS

54092

26,00€

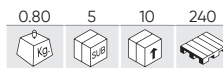

KIT DE CONTROLE E REGULAÇÃO DE FASE DE CRONOMETRAGEM PARA MOTOR 1.2 TFSI POR VAG (VW)



INFORMAÇÕES ADICIONAIS

53325

8,00€

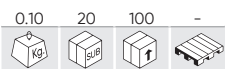

CHAVE DE POLIA TENSIONADORA PARA VW AUDI



INFORMAÇÕES ADICIONAIS

53321

12,00€

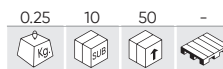

FERRAMENTA AJUSTE TENSÃO CORREIA VAG



INFORMAÇÕES ADICIONAIS

54409

34,00€

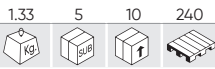

KIT DE BLOQUEIO VAG 1.4 TSI

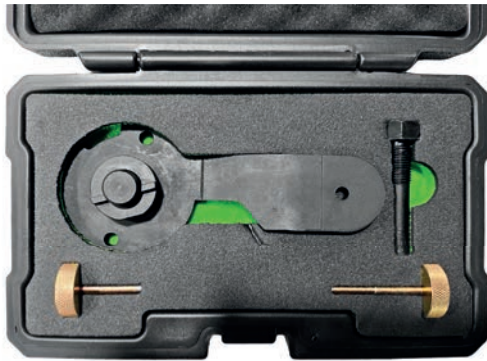

INFORMAÇÕES ADICIONAIS

53706

98,00€



KIT DE FERRAMENTAS DE SINCRONIZAÇÃO VAG 1.4, 1.6, 2.0 TDI COMMON RAIL

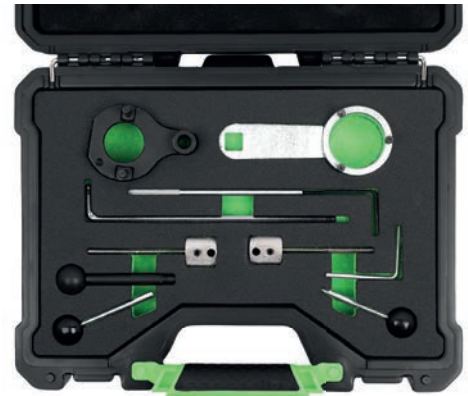

INFORMAÇÕES ADICIONAIS

54408

49,00€

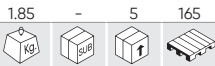

CONJUNTO DE FERRAMENTAS DE BLOQUEIO DO MOTOR VAG DIESEL 1.7, 1.9, SDI, TDI



INFORMAÇÕES ADICIONAIS

54411

38,00€

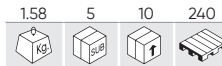

KIT DE BLOQUEIO VAG/PORSCHE 2.4, 2.8, 3.0 TFSI



INFORMAÇÕES ADICIONAIS

54410

36,00€

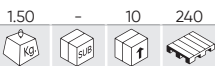

KIT DE BLOQUEIO VAG 2, 3.2 FSI



INFORMAÇÕES ADICIONAIS

53286

92,00€

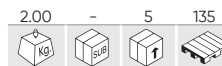

KIT DE BLOQUEIO VAG 1.8, 2.0 TSI, TFSI



INFORMAÇÕES ADICIONAIS

53287 258,00€

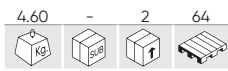

KIT DE BLOQUEIO VW/AUDI 1.8, 2.0L TURBO



INFORMAÇÕES ADICIONAIS



53648 107,00€



KIT DE BLOQUEIO DE DISTRIBUIÇÃO PARA VAG 1.2, 1.4 TSI



INFORMAÇÕES ADICIONAIS

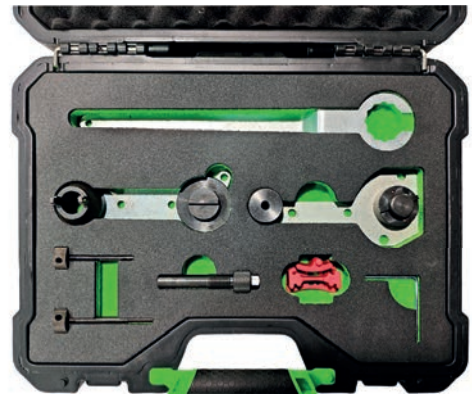

53649 89,00€

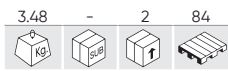

SET DE DISTRIBUIE PE GRUPO VAG



INFORMAÇÕES ADICIONAIS



53315 300,00€

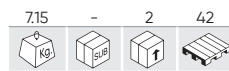

SET DE BLOQUEIO VOLVO 3.0, 3.2T6 / LAND ROVER 3.2



INFORMAÇÕES ADICIONAIS



54467 184,00€



KIT DE ASPIRAÇÃO GASOLINA-VOLVO 1.5/2.0



INFORMAÇÕES ADICIONAIS

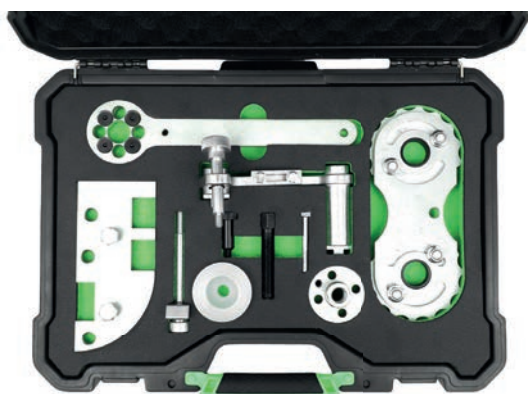

54466 115,00€



KIT DE ASPIRAÇÃO DIESEL-VOLVO 2.0D



INFORMAÇÕES ADICIONAIS



54431

194,00€

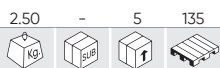

KIT DE BLOQUEIO ALFA ROMEO/MASERATI 2.9



INFORMAÇÕES ADICIONAIS

54413

121,00€



KIT DE BLOQUEIO AUDI 4.0 FSI, TFSI



INFORMAÇÕES ADICIONAIS

54412

60,00€

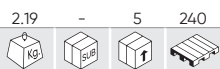

KIT DE BLOQUEIO AUDI 2.5 TFSI



INFORMAÇÕES ADICIONAIS

54226

75,00€



CONJUNTO DE EXTRATOR PARA POLIA DA BOMBA DE ALTA PRESSÃO PARA HYUNDAI/ KIA



INFORMAÇÕES ADICIONAIS

54200

59,00€

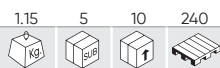

KIT DE BLOQUEIO DE DISTRIBUIÇÃO PARA PORSCHE



INFORMAÇÕES ADICIONAIS

54199

95,00€



KIT DE BLOQUEIO DE DISTRIBUIÇÃO PARA VAG TFSI, FSI

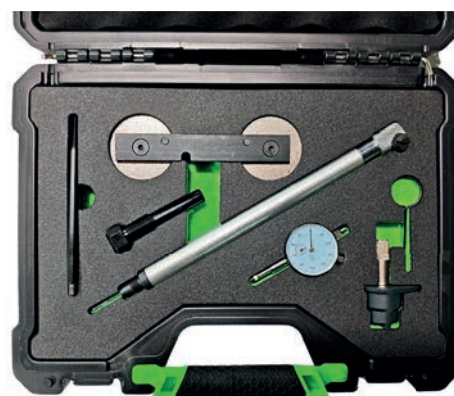

INFORMAÇÕES ADICIONAIS

54407

417,00€

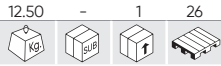

KIT DE FERRAMENTAS PARA O CONJUNTO DO EIXO-COMANDO DE VÁLVULAS VAG/PORSCHE



INFORMAÇÕES ADICIONAIS

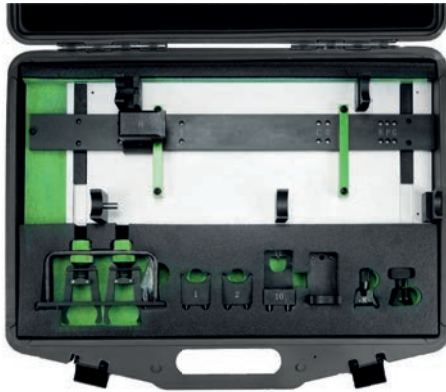

54218

150,00€



FERRAMENTA DE MONTAGEM DE AMORTECEDOR DE VIBRAÇÃO VAG



INFORMAÇÕES ADICIONAIS

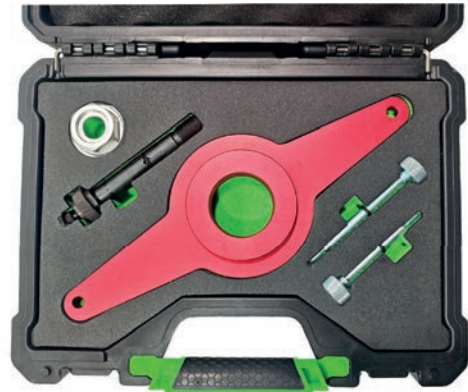

51340

39,30€

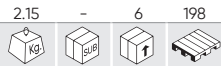

CHAVE UNIVERSAL PARA ÁRVORE DE CAMAS + ADAPTADORES



INFORMAÇÕES ADICIONAIS

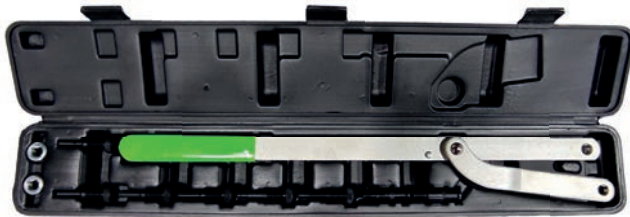

52616

47,00€

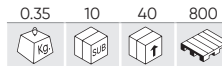

TENSIÓMETRO PARA CORREIA DE TRANSMISSÃO



INFORMAÇÕES ADICIONAIS

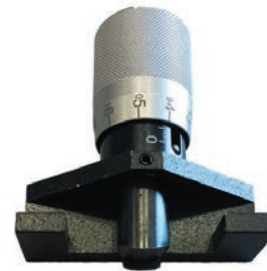

53769

195,00€

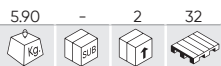

MÓDULO DE BLOQUEIO RENAULT/NISSAN/OPEL/VOLVO



INFORMAÇÕES ADICIONAIS



53770

221,00€



MÓDULO DE BLOQUEIO FORD/SEAT/VOLKSWAGEN/MAZDA/VOLVO



INFORMAÇÕES ADICIONAIS



53771

158,00€



MÓDULO DE BLOQUEIO FIAT/FORD/
CITROËN/PEUGEOT



INFORMAÇÕES
ADICIONAIS

53772

257,00€

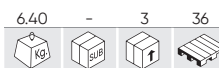

MÓDULO DE BLOQUEIO FORD/VAG/
MAZDA/VOLVO



INFORMAÇÕES
ADICIONAIS

53773

327,00€

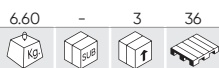

MODULO DE BLOQUEIO FIAT/ ALFA/LANCIA/
OPEL/SUZUKI/FORD



INFORMAÇÕES
ADICIONAIS

53774

208,00€

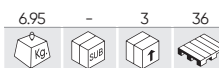

MÓDULO DE BLOQUEIO OPEL/CHEVROLET/
SAAB/FIAT/LANCIA/SUZUKI/FORD



INFORMAÇÕES
ADICIONAIS

CARROS DE FERRAMENTAS COM 7 GAVETAS

ESPECIAL KIT DE BLOQUEIO

REF.	GAVETAS	COR					€
53951	7	●	94.70	-	1	4	1.794,00€
53952	7	●	94.70	-	1	4	1.794,00€
54501	7	●	94.70	-	1	4	1.794,00€
54502	7	●	94.70	-	1	4	1.794,00€

CONTÉM

53775

1.378,00€



MÓDULO DE 6 FERRAMENTAS DE
SINCRONIZAÇÃO DE MOTOR



LUBRIFICAÇÃO/ COMBUSTÍVEL

336 BOMBAS DE ABASTECIMENTO DIESEL

338 BOMBAS DE ABASTECIMENTO DE UREIA

340 BOMBAS DE ENCHIMENTO/EXTRAÇÃO

344 COLETORES DE ÓLEO

345 BALDES DE COLEÇÃO DE ÓLEO

346 PISTOLAS DE SUÇÃO

346 OUTROS



53697

398,00€



BOMBA DE COMBUSTÍVEL DIESEL COM DOSADOR E INDICADOR (200-240V)

Tensão	220-240V
Potência	550W
Taxa de entrega	20-65L/min
Comprimento do cabo	2m
Comprimento da mangueira de aspiração	2m
Comprimento da mangueira de alimentação	4m
Tipo	Paro automático/Automatic stop
Peso	17,00Kg



REPOSIÇÕES DISPONÍVEIS



53610

298,00€

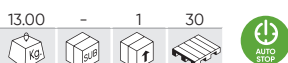

BOMBA DISPENSADORA DE DIESEL COM PISTOLA (230V)

Tensão	230V
Potência	550W
Taxa de entrega	60L/min
Altura máxima de sucção	3m
Comprimento da mangueira de aspiração	2m
Comprimento da mangueira de alimentação	4m
Tipo	Paro automático/Automatic stop
Peso	13,00Kg



REPOSIÇÕES DISPONÍVEIS



53609

194,00€

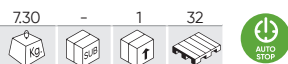

BOMBA DE ABASTECIMENTO DE DIESEL COM PISTOLA (12V)

Tensão	12V
Potência	175W
Taxa de entrega	45L/min
Altura máxima de sucção	3m
Comprimento da mangueira de aspiração	2m
Comprimento da mangueira de alimentação	4m
Tipo	Paro automático/Automatic stop
Peso	7,30Kg



REPOSIÇÕES DISPONÍVEIS



54877

2.990,00€



BOMBA PARA COMBUSTÍVEL DIESEL E AUS32 COM TANQUE DUPLO DE 330+50L

Tensão	12V
Potência	Diésel: 180W / AUS32: 120W
Pressão do trabalho	2,75BAR
Capacidade	Diésel 330L / AUS32 50L
Taxa de entrega	Diésel 40l/min, AUS32 17l/min
Comprimento do cabo	4m
Comprimento da mangueira de alimentação	4m
Tipo	Diésel: Automatic Stop, AUS32: Manual
Peso	68,00Kg
Dimensões (CxLxA)	1145x785x705mm



REPOSIÇÕES DISPONÍVEIS



54881 1.149,00€

34.00 - 1 3 **NEW**

BOMBA ELÉTRICA PARA COMBUSTÍVEL DIESEL COM TANQUE DE 210L



REPOSIÇÕES DISPONÍVEIS

54876 1.998,00€

52.00 - 1 2 **NEW**

BOMBA ELÉTRICA PARA COMBUSTÍVEL DIESEL COM TANQUE DE 400L



REPOSIÇÕES DISPONÍVEIS

Tensão	12V
Potência	180W
Pressão do trabalho	2,75BAR
Capacidade	210L
Taxa de entrega	40L/min
Comprimento do cabo	4m
Comprimento da mangueira de alimentação	4m
Tipo	Paro automático/Automatic stop
Peso	30,42Kg
Dimensões (CxLxA)	1100x800x450mm

Tensão	12V
Potência	180W
Pressão do trabalho	2,75BAR
Capacidade	400L
Taxa de entrega	40L/min
Comprimento do cabo	4m
Comprimento da mangueira de alimentação	4m
Tipo	Paro automático/Automatic stop
Peso	53,00Kg
Dimensões (CxLxA)	1140x800x710mm

54875 1.049,00€

28.00 - 1 4 **NEW**

BOMBA ELÉTRICA PARA COMBUSTÍVEL DIESEL COM TANQUE DE 200L



REPOSIÇÕES DISPONÍVEIS



54898 16,50€

0.13 10 10 2400 **NEW**

ADAPTADOR PARA ENCHIMENTO DE ÓLEO DA CAIXA DE CÂMBIO VAG DSG 7



Peças	2
Marcas	VAG
Peso	0,12Kg
Comprimento	245mm



54100

265,00€



BOMBA DIESEL ELÉTRICA 205L



Medição de voltagem em corrente alternada (AC)	12V
Medição de voltagem em corrente continua (DC)	100-240V
Taxa de entrega	18,4L/min
Comprimento do cabo	4m
Comprimento da mangueira de aspiração	850-1245mm
Comprimento da mangueira de alimentação	2m
Tipo	Diesel
Peso	4,00Kg

53645

268,00€



BOMBA ELÉTRICA PARA UREA AUS32 205L



REPOSIÇÕES DISPONÍVEIS

Medição de voltagem em corrente alternada (AC)	100-240V
Medição de voltagem em corrente continua (DC)	12V
Taxa de entrega	18,4L/min
Comprimento do cabo	2m
Comprimento da mangueira de aspiração	850-1245mm
Comprimento da mangueira de alimentação	2m
Tipo	UREA AUS32
Peso	3,10Kg

54880

790,00€



NEW



BOMBA DE ABASTECIMENTO ELÉTRICA AUS32 COM MEDIDOR ELETRÔNICO 280W



REPOSIÇÕES DISPONÍVEIS

Tensão	230V
Potência	280W
Pressão do trabalho	1,5BAR
Taxa de entrega	26L/min
Comprimento do cabo	2m
Comprimento da mangueira de aspiração	2m
Comprimento da mangueira de alimentação	4m
Tipo	Paro automático/Automatic Stop
Peso	13,00Kg

54878

890,00€

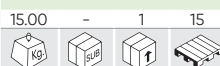

NEW



BOMBA ELÉTRICA DE FORNECIMENTO AUS32 COM CONTADOR ELETRÔNICO 370W



REPOSIÇÕES DISPONÍVEIS

Tensão	230V
Potência	370W
Pressão do trabalho	1,5BAR
Taxa de entrega	40L/min
Comprimento do cabo	2m
Comprimento da mangueira de aspiração	2m
Comprimento da mangueira de alimentação	4m
Tipo	Paro automático/Automatic stop
Peso	13,00Kg

54879

890,00€

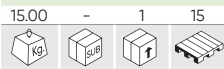

NEW



BOMBA DE FORNECIMENTO ELÉTRICO AUS32 COM CONTADOR ELETRÔNICO 370W

Tensão	230V
Potência	370W
Pressão do trabalho	1,5BAR
Taxa de entrega	40L/min
Comprimento do cabo	2m
Comprimento da mangueira de aspiração	2m
Comprimento da mangueira de alimentação	4m
Tipo	Paro automático/Automatic Stop
Peso	13,00Kg



REPOSIÇÕES DISPONÍVEIS

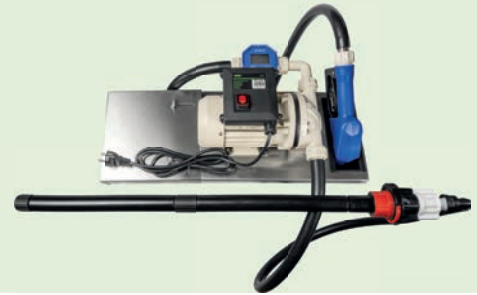

15631

98,00€

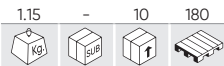

PISTOLA AUTOMÁTICA PARA UREA AUS 32



Entrada de fluido	19mm
Saída de fluido	15mm
Taxa de fluxo máxima	35L/min
Tipo	UREA AUS32
Compatível com	53645
Peso	1,15Kg

13982

4,00€

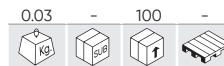

ADAPTADOR DE ROSCA DE TAMBORES PLÁSTICOS



Medida da rosca fêmea	570mm
Medida da rosca macho	555mm
Tipo	Urea AUS32
Peso	0,05Kg
Dimensões (CxLxA)	72x52x52mm

53644

1.238,00€

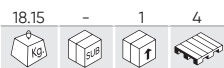

TANQUE DE UREA AUS32 75L



Tensão	12V
Potência	120W
Pressão do trabalho	2,75BAR (40PSI)
Capacidade	75L
Taxa de entrega	10L/min
Comprimento do cabo	4m
Comprimento da mangueira de alimentação	4m
Tipo	Paro automático/Automatic Stop
Peso	18,15Kg
Dimensões (CxLxA)	1040x410x520mm



52329

36,40€

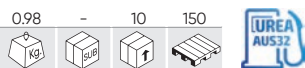

BOMBA MANUAL PLÁSTICA DE EXTRAÇÃO

Taxa de entrega	350ml (15L/min)
Comprimento da mangueira de aspiração	320-900mm
Compatível com	Bidones/Canisters 25L, 50L, 200L
Viscosidade	200mPas
Material	PP
Peso	0,98Kg



54882

519,00€



BOMBA ELÉTRICA PARA AUS32 COM TANQUE DE 50L

Tensão	12V
Potência	120W
Pressão do trabalho	2,75BAR
Capacidade	50L
Taxa de entrega	17L/min
Comprimento do cabo	4m
Comprimento da mangueira de alimentação	4m
Tipo	Pistola manual/Manual gun
Peso	12,00Kg
Dimensões (CxLxA)	570x380x450mm



REPOSIÇÕES DISPONÍVEIS



54514

109,00€



BOMBA PNEUMÁTICA/MANUAL PARA EXTRAÇÃO DE ÓLEO 6.5L



Capacidade	6,5L
Pressão do trabalho	2,76-11,72BAR
Entrada de ar	1/4"
Temperatura de trabalho	2/80°C
Peso	3,50Kg
Dimensões (CxLxA)	225x215x565mm

54555

149,00€



BOMBA DE TRANSMISSÃO PNEUMÁTICA 10L COM 15 ADAPTADORES



Capacidade	10L
Mangueiras	4
Adaptadores	15
Pressão do trabalho	2,8-11,7BAR
Entrada de ar	1/4"
Temperatura de trabalho	-3/140°C
Peso	4,00Kg
Dimensões (CxLxA)	280x245x530mm

52797

198,00€

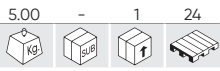

BOMBA MANUAL PARA SISTEMAS DE TRANSMISSÕES 7.5L

Capacidade	7,5L
Descarga	80cc
Viscosidade	140SAE
Contém	15 Adaptadores/Adapters
Peso	5,00Kg
Dimensões (CxLxA)	270x270x480mm



REPOSIÇÕES DISPONÍVEIS



53566

32,00€

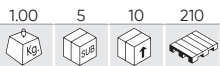

BOMBA DE ASPIRAÇÃO DE ÓLEO - 12V

Tensão	12V
Consumo de energia	5A
Potência	60-80W
Intensidade do som	70dB
Nível de fluidez (Diesel)	1,5 L/min
Nível de fluidez (Óleo de motor)	0,5 L/min
Medidas do tubo de aspiração	1,2m
Medidas do tubo de expiração	1,5m
Acionamento pneumático	1,00Kg



53627

22,50€

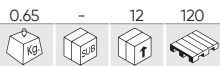

KIT DE EXTRAÇÃO DE ÓLEO E COMBUSTÍVEL 1.6L



Capacidade	1,6L
Comprimento da mangueira	1-1,3m
Peso	0,65Kg
Dimensões (CxLxA)	530x380x490mm



52601

397,00€

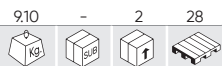

BOMBA PARA BIDÃO DE ÓLEO COM MANGUEIRA



REPOSIÇÕES DISPONÍVEIS



Taxa de compressão	5:1
Entrada de ar	1/4"
Saída de ar	1/2"
Pressão do trabalho	6-8BAR
Capacidade relativa	18L/min
Consumo real de ar	250L/min
Temperatura do óleo	-10/50°C
Viscosidade	240SAE
Comprimento do tubo	950mm
Comprimento da mangueira	4m
Peso	9,10Kg

50918

341,00€

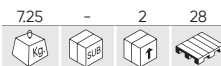

BOMBA PARA TAMBOR DE ÓLEO



REPOSIÇÕES DISPONÍVEIS



Taxa de compressão	5:1
Entrada de ar	1/4"
Saída de ar	1/2"
Pressão do trabalho	6-8BAR
Capacidade relativa	18L/min
Consumo real de ar	250L/min
Temperatura do óleo	-10/50°C
Viscosidade	240SAE
Comprimento do tubo	950mm
Peso	7,25Kg

50935

595,00€

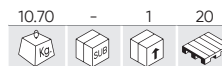

KIT BOMBA ÓLEO PARA TAMBOR DE ÓLEO+MANGUEIRA+PISTOLA ÓLEO DIGITAL



Taxa de compressão	5:1
Entrada de ar	1/4"
Saída de ar	1/2"
Pressão do trabalho	6-8BAR
Capacidade relativa	18L/min
Consumo real de ar	250L/min
Temperatura do óleo	-10/50°C
Viscosidade	240SAE
Comprimento do tubo	950mm
Comprimento da mangueira	2m
Peso	10,70Kg

50917

271,00€

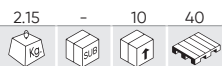

PISTOLA DE BOMBEAMENTO DE ÓLEO COM CAUDALÍMETRO DIGITAL



REPOSIÇÕES DISPONÍVEIS



Entrada de fluido	1/2"
Consumo real de ar	1-35L/min
Pressão do trabalho	6-8BAR
Pressão máxima	100BAR
Viscosidade	240SAE
Precisão do medidor de vazão	±0,5%
Repetibilidade do medidor de vazão	0,2%
Temperatura de trabalho	-10-60°C
Velocidade de descarga por revolução	25ml/R
Bateria	Pilas/Batteries
Peso	1,40Kg
Dimensões (CxLxA)	500x90x160mm

52428

44,00€

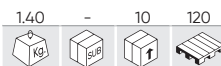

BOMBA MANUAL DE EXTRAÇÃO



Consumo real de ar	32L/min
Saída de fluido	Ø25mm
Entrada de fluido	Ø32mm
Comprimento do tubo	1016mm
Peso	1,40Kg

51253

44,00€



BOMBA DE ÓLEO MANUAL



Fluxo de trabalho	300ml
Entrada de fluido	Ø22,60mm
Saída de fluido	Ø16mm
Comprimento do tubo	890mm
Diâmetro de descarga	19mm
Diâmetro de sucção	35mm
Peso	2,06Kg
Dimensões (CxX)	465x1400mm

54050

895,00€

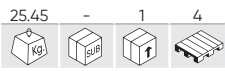

MÁQUINA DE TROCA DE ÓLEO DE TRANSMISSÃO AUTOMÁTICA

Tensão	12V
Potência	70W
Pressão do trabalho	0-10BAR (0-150PSI)
Capacidade do tanque de óleo novo	30L
Capacidade do depósito de óleo usado	30L
Peso	25,46Kg
Dimensões (CxLxA)	270x500x860mm



REPOSIÇÕES
DISPONÍVEIS



VIDEO
TUTORIAL



54290

4.307,00€

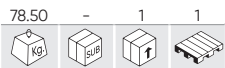

MÁQUINA DE TROCA DE ÓLEO DE TRANSMISSÃO AUTOMÁTICA

Tensão	220V
Potência	150W
Intensidade	50Hz
Velocidade de troca	2L/min
Faixa de trabalho	0-105PSI
Capacidade de óleo novo	20L
Capacidade de óleo usado	20L
Precisão do filtro	5µm
Comprimento da mangueira de saída	2,5m
Comprimento da mangueira de retorno	2,5m
Comprimento do tubo de drenagem	1,2m
Intensidade do som	<70dB
Temperatura de trabalho	-10/50°C
Peso	78,50Kg
Dimensões (CxLxA)	710x580x1040mm



REPOSIÇÕES
DISPONÍVEIS



VIDEO
TUTORIAL



54367

729,00€



KIT DE ADAPTADORES PARA REF. 54290 (105 PÇS)



INFORMAÇÕES
TÉCNICAS



55049

1.590,00€

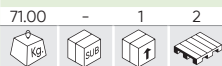

NEW

CARRINHO RECOLHEDOR DE ÓLEO COM SISTEMA DE ASPIRAÇÃO E COMPARTIMENTOS

Material	Acero/Steel
Capacidade do tanque	80L
Capacidade do coletor de peneiras	10L
Capacidade do copo medidor	10L
Pressão do trabalho	6-8 bar
Temperatura de trabalho	40-80°C
Peso	84,90Kg
Dimensões da gaveta	550x330x80mm
Dimensões (CxLxA)	800x400x1445mm



53873

285,00€



COLETOR DE ÓLEO COM 80 LITROS TANQUE



REPOSIÇÕES DISPONÍVEIS

Pressão do trabalho	1-3BAR
Capacidade do tanque	70L
Capacidade do coletor de peneiras	10L
Peso	18,00Kg
Dimensões (CxLxA)	350x480x1630mm



53874

398,00€



COLETOR DE ÓLEO COM SISTEMA DE ASPIRAÇÃO 90 LITROS TANQUE



REPOSIÇÕES DISPONÍVEIS



VÍDEO TUTORIAL

Pressão do trabalho	8-10BAR
Capacidade do tanque	70L
Capacidade do coletor de peneiras	10L
Capacidade do copo medidor	10L
Peso	22,00Kg
Dimensões (CxLxA)	430x490x1470mm



ACESSÓRIOS

REF.	DESCRIÇÃO					€
18368	FILTRO DE ESPONJA ANTIPROJEÇÕES PARA COLETORES DE ÓLEO REF.53873/53874	0.05	6	36	215	12,00€
17571	FILTRO PARA FUNIL DE DRENAGEM DE ÓLEO 53873 E 53874	0.40	-	100	20000	25,00€
15084	MÓDULO DE EXTRAÇÃO DE TAMPÕES DE CÂRTER	1.65	-	10	220	68,00€

50924

342,00€

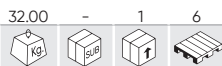





CARRO PORTA BIDÕES 200KG

Capacidade	200Kg
Material	Fe
Peso	31,00Kg
Dimensões (CxLxA)	990x790x830mm



TANQUE DE ARMAZENAMENTO DE TAMBOR

REF.	CAPACIDADE	CAPACIDADE TAMBORES	TAMBORES	MATERIAL						€
52804	400Kg	230L	1	PE	1000x680x600mm	14.50	-	1	5	343,00€
52805	650Kg	250L	2	PE	1300x750x440mm	13.35	-	1	6	426,00€
52806	1250Kg	250L	4	PE	1290x1290x280mm	17.50	-	1	5	742,00€
53214	650Kg	230L	2	PE	1310x910x380mm	16.50	-	1	12	285,00€



52804



52805



52806



53214

54498

6.090,00€

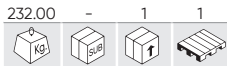

CAPA DURA DO IBC 2500KG

Capacidade	2500Kg
Capacidade dos contentores de 1000 litros	1
Capacidade dos tambores de 200 litros	4
Material	PE
Normas	DIBT
Peso	232,00Kg
Dimensões (CxLxA)	1775x1770x2500mm

* Contentor IBC não incluído



52807

1.714,00€



TANQUE DE ARMAZENAMENTO - CONTAINER IBC 2500KG

Capacidade	2500Kg
Capacidade de carga dos contêineres	1000L
Número de contêineres	1
Material	PE
Peso	30,00Kg
Dimensões (CxLxA)	1680x1680x700mm



53612

106,50€



BRAÇADEIRA PARA TAMBORES 500KG

Capacidade	500Kg
Material	S
Peso	4,75Kg
Dimensões (CxLxA)	745x99x148mm



52498

58,00€



PISTOLA DE SUÇÃO/INJEÇÃO
TRANSPARENTE 1500ML



Capacidade	1500ml
Material	PP
Comprimento do tubo	483mm
Comprimento da pistola	500mm
Peso	0,85Kg

52628

26,50€

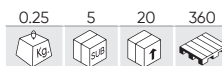

SERINGA DE SUÇÃO TRANSPARENTE
200ML



Capacidade	200ml
Material	PP
Comprimento do tubo	360mm
Comprimento da pistola	570mm
Peso	0,25Kg

52789

15,20€

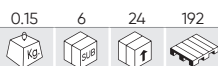

BOMBA MANUAL EXTRAÇÃO GASOIL



Comprimento da mangueira de alimentação	900mm
Comprimento da mangueira de aspiração	900mm
Material	0,15Kg
Peso	PVC

51928

14,00€

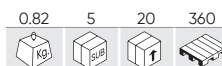

SERINGA DE SUÇÃO DE ÓLEO 0,5L



Capacidade	0,5L
Material	Cromado/Chrome Finish
Comprimento do tubo	275mm
Comprimento da pistola	340mm
Peso	0,82Kg

53215

19,00€



RECOLHEDOR DE ANTICONGELANTE. 18L



Cor	Verde/Green
Capacidade	18L
Material	PE
Peso	0,95Kg
Dimensões (CxLxA)	550x460x180mm

53144

18,00€



RECOLHEDOR DE ÓLEO 18L



Cor	Negro/Black
Capacidade	18L
Material	PE
Peso	0,99Kg
Dimensões (CxLxA)	550x460x180mm

54558

11,50€



BANDEJA DE ÓLEO PARA CAMIÕES E REBOQUES



Capacidade do tanque	2,5L
Capacidade do copo medidor	500/1000/1500/2000/2500ml
Material	HDPE
Peso	0,30Kg
Dimensões (CxLxA)	345x185x150mm

54051

39,00€

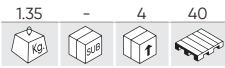

BANDEJA DE TROCA DE ÓLEO 8 L



Capacidade	8L
Material	PE
Peso	1,35Kg
Dimensões (CxLxA)	600x330x110mm

51356

59,00€

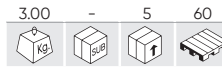

BANDEJA DE AÇO PARA LÍQUIDOS 23L



Capacidade	23L
Material	S
Peso	3,00Kg
Dimensões (CxLxA)	400x600x110mm

BIDÃO DE METAL PARA COMBUSTÍVEL

REF.	L	mm	MATERIAL					€
54181	5L	241x115x311mm	Aço	1.45	-	4	72	27,50€
54182	10L	284x133x386mm	Aço	2.55	-	4	48	38,50€
54183	10L	240x140x355mm	Aço	2.75	-	6	48	42,00€
54184	20L	356x166x460mm	Aço	4.10	-	4	24	49,00€

54181



REPOSIÇÕES DISPONÍVEIS



54182



REPOSIÇÕES DISPONÍVEIS



54183



REPOSIÇÕES DISPONÍVEIS



54184



REPOSIÇÕES DISPONÍVEIS



ACESSÓRIOS

REF.	DESCRIÇÃO					€
53078	TORNEIRA PARA BIDÃO DE 200L	0.25	5	25	300	22,00€
53518	TORNEIRA DE PLÁSTICO DE 3/4" PARA BIDÃO DE ÓLEO	0.05	10	500	3000	3,50€
52453	TORNEIRA DE 3/4" PARA BIDÃO DE ÓLEO DE 200L	0.19	5	100	800	26,00€
15874	BOQUILHA FLEXÍVEL PARA BIDÃO METÁLICO (REF.54181, 54182, 54183, 54184)	0.30	-	50	800	7,00€



53078



53518



52453



15874



52991

10,50€

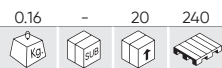

JARRO COM PESCOÇO FLEXÍVEL 2L



Capacidade	2L
Material	PP, PE
Peso	0,16Kg

52992

22,50€



JARRO COM PESCOÇO FLEXÍVEL 5L



Capacidade	5L
Material	PP, PE
Peso	0,30Kg

52242

12,00€



GALHETAS DE ÓLEO 500ML



Capacidade	500ml
Comprimento do tubo	160mm
Peso	0,28Kg

52243

8,50€



GALHETAS DE ÓLEO 250ML



Capacidade	250ml
Comprimento do tubo	125mm
Peso	0,14Kg

53187

39,00€

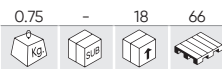

FUNIL PARA BIDÃO DE 200L COM TAMPA E FILTRO



Diâmetro	260mm
Material	PP
Peso	0,75Kg

53188

7,00€

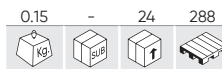

JOGO DE 3 FUNILS



Diâmetro	90, 130, 180mm
Material	PP
Peso	0,15Kg

52391

5,00€

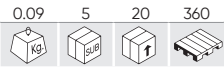

FUNIL COM FILTRO



Material	PP
Dimensões do tubo	250x100mm
Dimensões do funil	140x175mm
Peso	0,09Kg

54719

16,50€

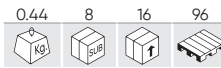

FUNIL DE ÓLEO COM SUPORTE



Diâmetro	125mm
Material	PVC
Peso	0,44Kg
Dimensões (CxLxA)	300x130x220mm

53198

9,50€

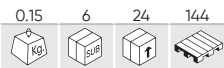

FUNIL COM TUBO FLEXÍVEL



Material	PP
Dimensões do tubo	530mm
Dimensões do funil	180mm
Peso	0,15Kg

53849

16,10€

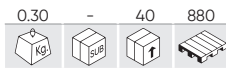

PISTOLA DE LUBRIFICAÇÃO COMPACTA



Capacidade	80cc
Pressão do trabalho	1000PSI
Material	S
Diâmetro	3,8mm
Peso	0,30Kg

54677

9,90€

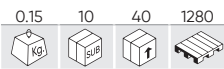

FERRAMENTA DE LIMPEZA DO BOCAL DE LUBRIFICAÇÃO



Peças	5
Material	PA
Comprimento	250mm
Peso	0,15Kg
Dimensões (CxLxA)	300x85x20mm

54255

74,00€

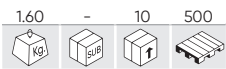

CONJUNTO COMPLETO DE ACESSÓRIOS PISTOLA DE LUBRIFICAÇÃO



Peças	7
Extensão de mangueira	300mm
Adaptadores	90-360°
Peso	1,60Kg
Dimensões (CxLxA)	260x170x60mm

50852 25,50€

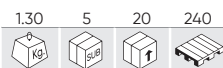

PISTOLA GRAXEIRA MANUAL COM TUBO FLEXÍVEL



Capacidade	500ml
Pressão do trabalho	20Mpa
Diâmetro interior	5mm
Diâmetro exterior	14mm
Peso	1,30Kg

50751 44,00€

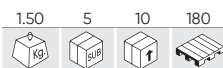

BOMBA DE MASSA PNEUMÁTICA



Entrada de ar	1/4"
Capacidade	500ml
Pressão do trabalho	6,2BAR
Pressão máxima	30Mpa
Peso	1,50Kg

53592 25,00€

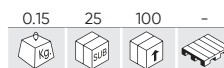

ACOPLADOR DE LIBERAÇÃO RÁPIDA PARA PISTOLA DE GRAXA



Entrada de ar	1/8"
Pressão do trabalho	1034BAR
Compatível com	50751, 50852
Peso	0,15Kg

60038 255,00€



PISTOLA DE GRAXA A BATERIA

Tensão	20V
Pressão máxima	620BAR
Volume/vazão	200g/min
Capacidade do cartucho	420g
Capacidade de graxa a granel	600g
Capacidade de graxa a granel	Hasta/Up to NLGI#2
Comprimento	760mm
Modos de carregamento	Granel/Bulk, Cartucho/Cartridge, Succión/Suction
LED	Si/Yes
Compatível com	60012, 60013, 60015, 60016, 60017
Peso	3,60Kg
Dimensões (CxLxA)	400x90x270mm



REPOSIÇÕES DISPONÍVEIS

60038C 411,00€



PISTOLA DE GRAXA A BATERIA COM MALETA

Tensão	20V
Pressão máxima	620BAR
Volume/vazão	200g/min
Capacidade do cartucho	420g
Capacidade de graxa a granel	600g
Capacidade de graxa a granel	Hasta/Up to NLGI #2
Comprimento	760mm
Modos de carregamento	Granel/Bulk, Cartucho/Cartridge, Succión/Suction
Inclui	60038, 60013, 60016
LED	Si/Yes
Compatível com	60012, 60013, 60015, 60016, 60017
Peso	7,30Kg
Dimensões (CxLxA)	400x90x270mm



REPOSIÇÕES DISPONÍVEIS



PÁGINA 153

PILHAS E CARREGADORES NÃO INCLUÍDOS NAS FERRAMENTAS INDIVIDUAIS

Três tipos de bateria e dois tipos de carregador. Escolha o que você preferir!



FERRAMENTAS HIDRÁULICAS

352 MACACOS HIDRAULICOS DE RODAS

355 MACACOS TIPO GARRAFA

356 MACACOS DE MANIVELA

356 MACACO HIDRÁULICO TELESCÓPICO

357 CAVALETES

358 OUTROS

359 PORTA PALETES MANUAL

360 PRENSAS

361 GUINDASTES

363 MESAS DE ELEVAÇÃO

365 BASES SE ELEVAÇÃO

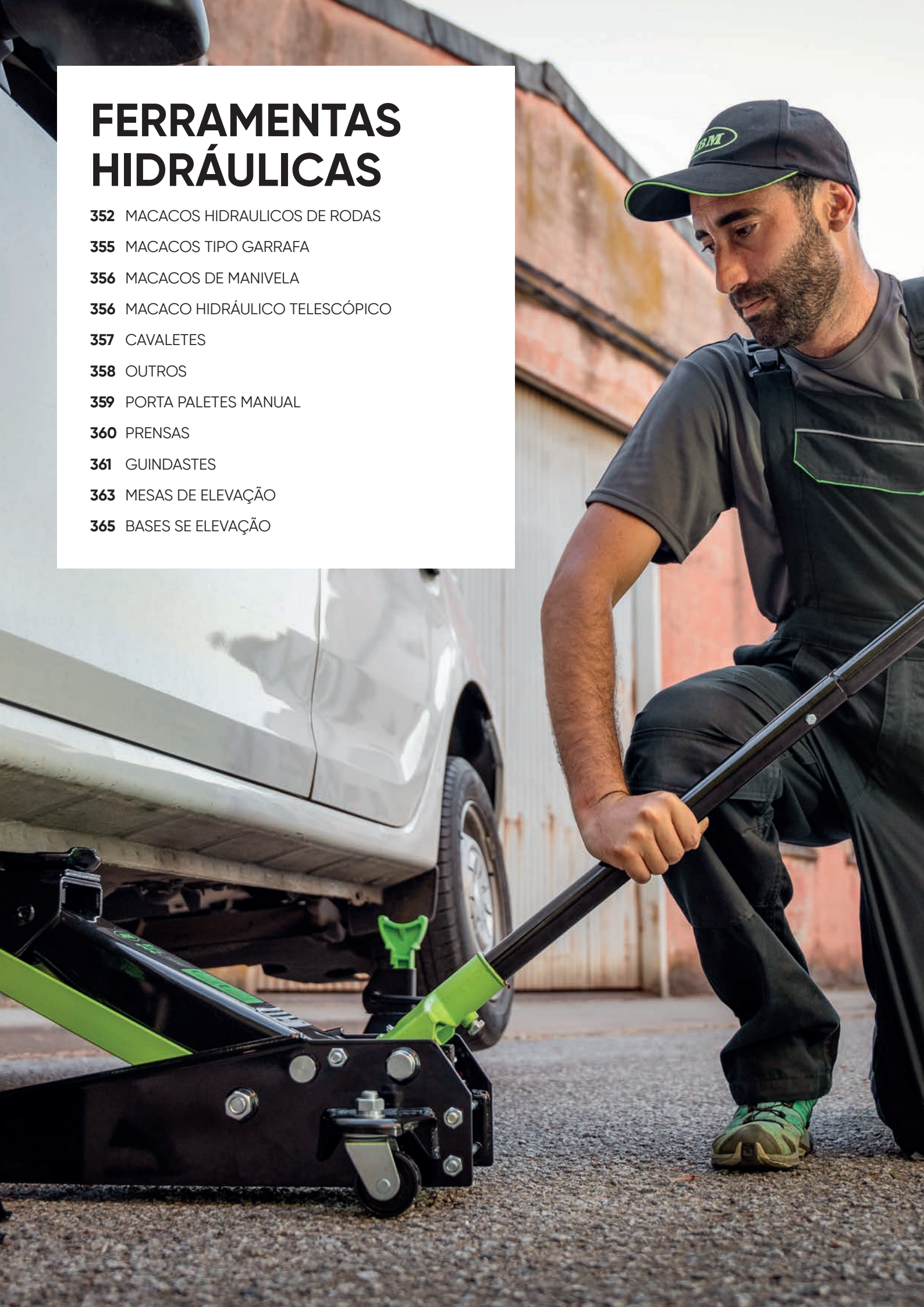

TUTORIAL DE MANUTENÇÃO

CONSELHOS BÁSICOS PARA A MANUTENÇÃO CORRETA DOS NOSSOS MACACOS PARA PROLONGAR A SUA VIDA ÚTIL E SEGURANÇA



53725

248,00€

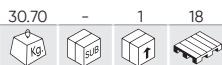

MACACO HIDRÁULICO DE RODAS 3T - SISTEMA RÁPIDO



REPOSIÇÕES DISPONÍVEIS



Capacidade	3T
Altura mínima	133mm
Altura máxima	465mm
Ajuste de altura	Rápida/Fast
Conformidade com a diretiva europeia	EN 1494:2001+A1
Peso	30,70Kg
Dimensões (CxLxA)	682x155x344mm

50818

198,00€

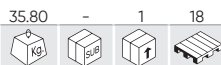

MACACO HIDRÁULICO COM RODAS 3,5T



REPOSIÇÕES DISPONÍVEIS



Capacidade	3,5T
Altura mínima	133mm
Altura máxima	495mm
Conformidade com a diretiva europeia	EN 1494:2000
Peso	35,80Kg
Dimensões (CxLxA)	685x180x346mm

53422

368,00€



MACACO HIDRÁULICO 3T COM ALAVANCA DE ELEVAÇÃO



REPOSIÇÕES DISPONÍVEIS



Capacidade	3T
Altura mínima	100mm
Altura máxima	533mm
Conformidade com a diretiva europeia	EN1494:2000+A1
Peso	44,50Kg
Dimensões (CxLxA)	778x165x372mm

53112

298,00€



MACACO HIDRÁULICO COM PEDAL



REPOSIÇÕES DISPONÍVEIS



Capacidade	3T
Altura mínima	140mm
Altura máxima	520mm
Conformidade com a diretiva europeia	EN1494:2000+A1
Peso	39,95Kg
Dimensões (CxLxA)	720x185x345mm

50815

88,00€



MACACO HIDRÁULICO DE RODAS 2T



REPOSIÇÕES DISPONÍVEIS



Capacidade	2T
Altura mínima	130mm
Altura máxima	355mm
Conformidade com a diretiva europeia	EN1494:2000+A1
Peso	10,75Kg
Dimensões (CxLxA)	490x140x205mm

51895

99,00€



MACACO HIDRÁULICO COM RODAS 2T EM CAIXA PLÁSTICA



REPOSIÇÕES DISPONÍVEIS



Capacidade	2T
Altura mínima	130mm
Altura máxima	355mm
Conformidade com a diretiva europeia	EN1494
Peso	11,68Kg
Dimensões (CxLxA)	490x140x205mm

SÃO UMA ADAPTAÇÃO IDEAL PARA VEÍCULOS DE PERFIL BAIXO, GRAÇAS À SUA ALTURA REDUZIDA E PROJETO EM CURVA



50816 88,00€

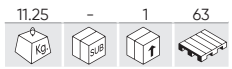

MACACO HIDRÁULICO DE RODAS 2T ESPECIAL CARROS BAIXOS



REPOSIÇÕES DISPONÍVEIS



Capacidade	2T
Altura mínima	85mm
Altura máxima	330mm
Conformidade com a diretiva europeia	EN1494+A1
Peso	11,25Kg
Dimensões (CxLxA)	508x125x208mm

53421 298,00€



MACACO HIDRÁULICO DE RODAS 2T ESPECIAL CARROS BAIXOS



REPOSIÇÕES DISPONÍVEIS



Capacidade	2T
Altura mínima	75mm
Altura máxima	505mm
Conformidade com a diretiva europeia	EN1494
Peso	33,50Kg
Dimensões (CxLxA)	740x150x360mm

54137 288,00€



MACACO HIDRÁULICO DE RODAS 2,5T ESPECIAL CARROS BAIXOS



REPOSIÇÕES DISPONÍVEIS



Capacidade	2,5T
Altura mínima	78mm
Altura máxima	505mm
Conformidade com a diretiva europeia	EN1494:2000+A1
Peso	30,65Kg
Dimensões (CxLxA)	740x150x350mm

54786 319,00€



NEW

MACACO HIDRÁULICO DE RODAS 3T ESPECIAL CARROS BAIXOS



REPOSIÇÕES DISPONÍVEIS



Capacidade	3T
Altura mínima	75mm
Altura máxima	505mm
Conformidade com a diretiva europeia	EN 1494:2000+A1
Peso	35,50Kg
Dimensões (CxLxA)	738x353x156mm

60065 899,00€



NEW

MACACO HIDRÁULICO DE CARRINHO 3T DE BAIXO PERFIL A BATERIA



REPOSIÇÕES DISPONÍVEIS



Capacidade	3T
Compatível com	60013, 60015, 60016, 60017
Tensão	20V
LED	No
Altura mínima	85mm
Altura máxima	508mm
Tempo de elevação (sem carga)	18-20s
Tempo de descida (sem carga)	7-10s
Tempo de elevação (com carga)	48-60s
Tempo de descida (com carga)	10-12s
Peso	41,00Kg
Dimensões (CxLxA)	770x355x1107mm

54516

940,00€

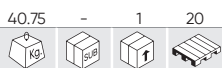

MACACO JACARÉ OLEO-PNEUMÁTICO TELESCÓPICO PARA 20/40T



REPOSIÇÕES DISPONÍVEIS

Capacidade	20/40T
Altura mínima	150mm
Altura máxima	227-295mm
Conformidade com a diretiva europeia	ENISO12100, EN1494
Adaptadores	35-65mm
Entrada de ar	1/4"
Pressão do trabalho	7-10BAR
Consumo real de ar	9,5CFM
Peso	40,75Kg
Dimensões (CxLxA)	900x290x1195mm

54517

1.184,00€

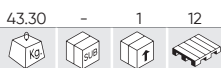

MACACO JACARÉ OLEO-PNEUMÁTICO TELESCÓPICO PARA 15/20/40T



REPOSIÇÕES DISPONÍVEIS

Capacidade	15/25/40T
Altura mínima	125mm
Altura máxima	185-240-301mm
Conformidade com a diretiva europeia	ENISO12100, EN1494
Adaptadores	35-65mm
Entrada de ar	1/4"
Pressão do trabalho	7-10BAR
Consumo real de ar	9,5CFM
Peso	43,30Kg
Dimensões (CxLxA)	918x285x1195mm

54751

617,00€



MACACO OLEO-PNEUMÁTICO EMPILHADOR DE 22 TONELADAS



REPOSIÇÕES DISPONÍVEIS

Capacidade	22T
Altura mínima	228mm
Altura máxima	548mm
Adaptadores	20-60-90mm
Entrada de ar	1/4"
Pressão do trabalho	7-10BAR
Consumo real de ar	9,5CFM
Extensível	110mm
Peso	44,00Kg
Dimensões (CxLxA)	1390x575x322mm

54916

88,50€

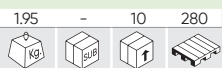

NEW

SUPORTE PARA MACACO HIDRÁULICO 3.5T



Material	Q235+45carbon steel
Capacidade	3,5T
Altura mínima	230mm
Altura máxima	380mm
Peso	1,95Kg
Dimensões (CxLxA)	64x48x227mm

54757

144,00€



2T SUPORTE TRANSVERSAL PARA MACACO HIDRÁULICO



VÍDEO TUTORIAL

Compatível com	50818, 53112
Capacidade	1350-2000Kg
Comprimento	700-925mm
Altura de trabalho	50-130mm
Peso	10,60Kg
Dimensões (CxLxA)	700x120x140mm



MACACO TIPO GARRAFA

50819 28,00€

2,42 - 6 300



Capacidade	2T
Altura mínima	181mm
Altura máxima	345mm
Peso	2,43Kg
Dimensões (CxLxA)	95x110x190mm

50820 34,50€

3,20 - 6 300



Capacidade	3T
Altura mínima	194mm
Altura máxima	371mm
Peso	3,20Kg
Dimensões (CxLxA)	105x110x210mm

50821 47,00€

4,10 - 5 250



Capacidade	5T
Altura mínima	216mm
Altura máxima	413mm
Peso	4,10Kg
Dimensões (CxLxA)	120x115x230mm

50822 59,00€

5,60 - 4 200



Capacidade	10T
Altura mínima	230mm
Altura máxima	460mm
Peso	5,60Kg
Dimensões (CxLxA)	135x135x240mm

52304 86,00€

7,20 - 2 136



Capacidade	15T
Altura mínima	230mm
Altura máxima	460mm
Peso	7,20Kg
Dimensões (CxLxA)	140x140x250mm

50823 94,00€

9,75 - 2 96



Capacidade	20T
Altura mínima	242mm
Altura máxima	452mm
Peso	9,75Kg
Dimensões (CxLxA)	175x165x250mm

50824 88,00€

8,47 - 2 120



Capacidade	20T
Altura mínima	190mm
Altura máxima	335mm
Peso	8,47Kg
Dimensões (CxLxA)	175x200x160mm

50825 154,00€

14,00 - 2 96



Capacidade	30T
Altura mínima	285mm
Altura máxima	465mm
Peso	14,00Kg
Dimensões (CxLxA)	140x150x250mm

MACACO TIPO GARRAFA COM CAIXA PLÁSTICA

51905 34,50€

2,90 - 6 144



Capacidade	2T
Altura mínima	181mm
Altura máxima	345mm
Peso	2,90Kg
Dimensões (CxLxA)	110x165x245mm

51906 39,00€

3,53 - 4 112



Capacidade	3T
Altura mínima	194mm
Altura máxima	371mm
Peso	3,53Kg
Dimensões (CxLxA)	110x170x280mm

51907 48,00€

4,59 - 4 128



Capacidade	5T
Altura mínima	216mm
Altura máxima	413mm
Peso	4,59Kg
Dimensões (CxLxA)	200x130x290mm

JACK ELEVADOR 3T

53895 117,00€

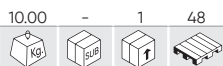

REPOSIÇÕES DISPONÍVEIS



Capacidade	3T
Altura mínima	130mm
Altura máxima	510mm
Peso	10,00Kg
Dimensões (CxLxA)	510x265x140mm

53896 142,00€



REPOSIÇÕES DISPONÍVEIS



Capacidade	3T
Altura mínima	130mm
Altura máxima	645mm
Peso	11,50Kg
Dimensões (CxLxA)	840x265x140mm

53897 159,50€

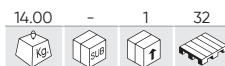

REPOSIÇÕES DISPONÍVEIS

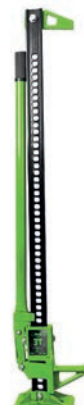

Capacidade	3T
Altura mínima	130mm
Altura máxima	1045mm
Peso	14,00Kg
Dimensões (CxLxA)	1220x265x140mm

53898 174,50€



REPOSIÇÕES DISPONÍVEIS



Capacidade	3T
Altura mínima	130mm
Altura máxima	1320mm
Peso	16,00Kg
Dimensões (CxLxA)	1520x265x140mm

54001 285,00€

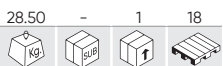

MACACO HIDRÁULICO DE FOSSA 0,5T



REPOSIÇÕES DISPONÍVEIS



VÍDEO TUTORIAL



Peças	1
Capacidade	500Kg
Altura mínima	1100mm
Altura máxima	1900mm
Peso	28,50Kg
Medidas da cabeceira	650x650x1100mm

50830 560,00€

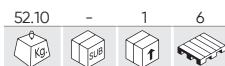

MACACO HIDRÁULICO DE TRANSMISSÃO 0,5 TON.



REPOSIÇÕES DISPONÍVEIS



Peças	1
Capacidade	500Kg
Altura mínima	850mm
Altura máxima	1740mm
Peso	52,10Kg
Dimensões (CxLxA)	970x970x900mm



CONJUNTO DE 2 PREGUIÇAS

REF.	T	mm					€
53779	3T	290-430mm	4.85	-	1	72	36,00€
53845	6T	370-610mm	9.35	-	1	31	64,00€
54143	12T	500-770mm	35.50	-	1	12	249,00€

CONJUNTO DE 2 PREGUIÇAS 10 TON

REF.	T	mm					€
54145	10T	482-775mm	37.90	-	1	4	389,00€
54146	10T	736-1212mm	2.00	-	1	4	492,00€



54144

298,00€

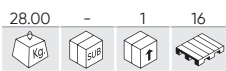

CONJUNTO DE 2 SUPORTES DE MACACO 22 TON (338-500MM)



Peças	2
Capacidade	22T
Altura mínima	338mm
Altura máxima	500mm
Peso	28,00Kg
Dimensões (CxLxA)	250x250x338mm

54147

199,00€

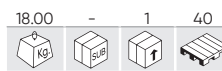

CAVALETE DE ELEVAÇÃO 1,8 TON (1220-2146MM)



Peças	1
Capacidade	1.8T
Altura mínima	1220mm
Altura máxima	2146mm
Peso	18,00Kg
Dimensões (CxLxA)	620x520x1220mm



51901

999,00€

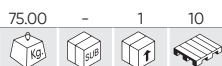

PORTA RODAS HIDRÁULICO CAP. 1T.



Capacidade	1T
Altura mínima	50mm
Altura máxima	320mm
Diâmetro máximo da roda	1320mm
Peso	75,00Kg
Dimensões (CxLxA)	1040x1090x890mm

52241

1.690,00€



PORTA RODAS HIDRÁULICO 1.5TON



Capacidade	1,5T
Altura mínima	0mm
Altura máxima	770mm
Diâmetro máximo da roda	2200mm
Peso	155,00Kg
Dimensões (CxLxA)	1270x990x1340mm

53218

26,00€



MACACO DE TESOURA 1.5T



Peças	2
Capacidade	1,5T
Altura mínima	90mm
Altura máxima	370mm
Peso	2,25Kg
Dimensões (CxLxA)	430x90x90mm

54257

318,00€



BOMBA HIDRÁULICA MANUAL 1.2L



Capacidade	1,2L
Pressão máxima	69BAR
Fluxo de trabalho	0-20Kg/cm3-20-700Kg/cm3
Conectores	3/8"NPT
Peso	11,40Kg
Dimensões (CxLxA)	750x180x270mm

50835

298,00€



DOBRADORA DE TUBOS 12T



Capacidade	12T
Pressão do trabalho	7,5-8,5BAR
Conectores	1/2", 3/4", 1"-1/4", 1"-1/2", 2"
Nível de ângulo	90°
Peso	38,00Kg
Dimensões (CxLxA)	680x585x185mm

53880

598,00€

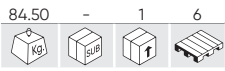

PORTA PALETES MANUAL ELEVÇÃO RÁPIDA

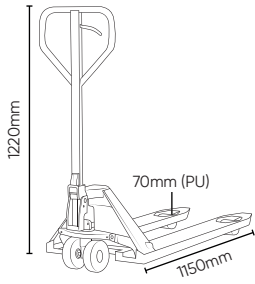

REPOSIÇÕES DISPONÍVEIS



VÍDEO TUTORIAL



Capacidade	2500Kg
Altura mínima de elevação	85mm
Altura máxima de elevação	200mm
Raio de giro	1266mm
Velocidade de elevação (com/sem carga)	0,0006-0,0007m/s
Tipo	Freno manual/Manual brake
Peso	84,50Kg
Dimensões (CxA)	1220x1150mm

54396

2.250,00€



EMPILHADOR DE PALETS ELÉCTRICO 1500KG

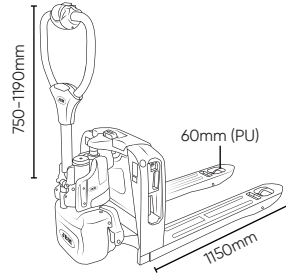

REPOSIÇÕES DISPONÍVEIS



Capacidade	1500Kg
Altura mínima de elevação	85mm
Altura máxima de elevação	190mm
Raio de giro	1360mm
Velocidade de deslocamento (com/sem carga)	4-4,5Km/h
Velocidade de elevação (com/sem carga)	0,017-0,020m/s
Potência	0,75KW
Tipo	Freno electromagnético/Electromagnetic brake
Tipo de pilha	LI-ION
Tensão da bateria	24V
Capacidade da bateria	20Ah
Tempo de carregamento	3-4h
Peso	112,00Kg
Dimensões (CxA)	1190x1150mm

50839

198,00€

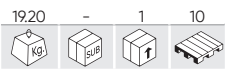

PORTA CARROS HIDRÁULICO 680KG



REPOSIÇÕES DISPONÍVEIS



Capacidade	680Kg
Abertura	345-660mm
Peso	1920Kg
Dimensões (CxLxA)	680x625x230mm

50923

454,00€

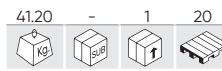

CARRO TRANSPORTADOR ESP. CHAPEIROS 340KG



REPOSIÇÕES DISPONÍVEIS



Capacidade	340Kg
Abertura	0-1100mm
Peso	41,20Kg
Dimensões (CxLxA)	1340x250x240mm

52514

88,00€

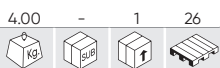

SUPORTE ELEVADOR DE MOTAS 200KG



REPOSIÇÕES DISPONÍVEIS



Capacidade	200Kg
Peso	4,00Kg
Dimensões (CxLxA)	750x400x530mm

51751

99,00€



SUPORTE ELEVADOR DE MOTAS 200KG



REPOSIÇÕES DISPONÍVEIS



Capacidade	200Kg
Peso	5,00Kg
Dimensões (CxLxA)	830x400x660mm

53684

1.880,00€



PRENSA HIDRÁULICA 30 TON



REPOSIÇÕES DISPONÍVEIS



Capacidade	30T
Curso do pistão	150mm
Faixa de trabalho	166-1126mm
Velocidades	2
Operado	Hidráulico manual o de pedal/Hydraulic by hand or foot
Peso	191,00Kg
Dimensões (CxLxA)	1920x750x290mm

53590

1.190,00€



PRENSA HIDRÁULICA 20 TON



REPOSIÇÕES DISPONÍVEIS



Capacidade	20T
Curso do pistão	145mm
Faixa de trabalho	58-1018mm
Velocidades	2
Operado	Hidráulico manual o de pedal/Hydraulic by hand or foot
Peso	114,50Kg
Dimensões (CxLxA)	1670x730x255mm

54679

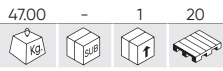

PRENSA HIDRÁULICA DE MESA 10T

Capacidade	10T
Curso do pistão	154mm
Faixa de trabalho	200-370mm
Operado	Hidráulico manual/Hydraulic by hand
Largura de trabalho	350mm
Pistão com deslocamento lateral	Si/Yes
Peso	47,00Kg
Dimensões (CxLxA)	550x500x1028mm



REPOSIÇÕES DISPONÍVEIS



389,00€

52999

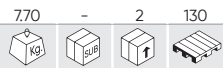

BASE DE TRABALHO PARA PRENSA



198,00€

54597



BASE DE SUPORTE PARA INSERÇÃO I EXTRAÇÃO DE CHUMACEIRAS



125,00€

50831

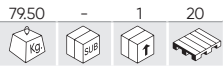

GRUA DE 2 TON DOBRÁVEL



REPOSIÇÕES DISPONÍVEIS

Capacidade	2T
Dimensões dobradas	1480x980x800mm
Tipo de fluido	Aceite pistón/Piston Oil - SAE 32
Altura máxima de elevação	0-2170mm
Modos de carregamento	4
Peso	79,50Kg
Dimensões (CxLxA)	1650x920x1480mm

52985



GRUA DE 1T DOBRÁVEL



REPOSIÇÕES DISPONÍVEIS

Capacidade	1T
Dimensões dobradas	1470x300x180mm
Tipo de fluido	Aceite hidráulico/Hydraulic oil HL, HM
Altura máxima de elevação	85-2200mm
Modos de carregamento	3
Peso	74,00Kg
Dimensões (CxLxA)	1400x950x1460mm

50840

138,00€

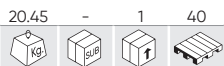

SUPORE PARA MOTORES 500KG (1750MM)



REPOSIÇÕES
DISPONÍVEIS

Capacidade	500Kg
Comprimento	1750mm
Peso	20,45kg

52055

139,00€



SUPORE DE MOTOR UNIVERSAL 500KG



Capacidade	500Kg
Peso	8,50Kg
Dimensões (CxLxA)	1000x500x320mm

55135

228,00€

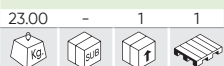

SUPORE UNIVERSAL EXTENSÍVEL PARA MOTORES

Capacidade	500Kg
Comprimento	1700mm
Peso	23,00kg



50631

68,00€

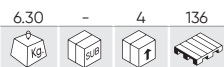

SUPORE ALINHADOR DE MOTOR 750KG

Capacidade	750Kg
Peso	6,30kg
Dimensões (CxLxA)	460x200x55mm



53423

199,00€

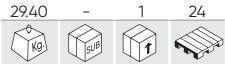

MACACO ELEVAÇÃO QUAD 680KG



REPOSIÇÕES
DISPONÍVEIS



Capacidade	680Kg
Altura mínima	118mm
Altura máxima	368mm
Peso	29,40Kg
Dimensões (CxLxA)	815x390x155mm

53969

96,00€

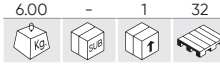

ELEVADOR DE MOTAS 150KG



Peças	2
Capacidade	150Kg
Altura mínima	300mm
Altura máxima	400mm
Peso	6,00Kg
Dimensões (CxLxA)	340x310x320mm

50836

148,00€

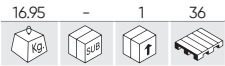

SUPORTE PARA MOTORES
340KG



Capacidade	340Kg
Peso	21,00Kg
Dimensões (CxLxA)	900x800x850mm

50838

299,00€

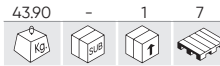

SUPORTE PARA MOTORES
900KG



Capacidade	900Kg
Movimento	x6 Posiciones/Positons, 360°
Peso	43,90Kg
Dimensões (CxLxA)	1100x900x900mm

52845

185,00€

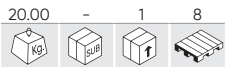

SET DE 2 RAMPA PARA ELEVAR 1 TON



Peças	2
Capacidade	1T (500kg/ramp)
Altura de elevação	0-200mm
Peso	20,00Kg
Dimensões (CxLxA)	940x300x210mm



54386

5.839,00€

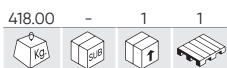

ELEVADOR PARA MONTAGEM DE BATERIAS EM VEÍCULOS ELÉCTRICOS 1200KG



REPOSIÇÕES DISPONÍVEIS
VIDEO TUTORIAL



Capacidade	1200Kg
Altura máxima de elevação	1840mm
Altura mínima de elevação	650mm
Dimensões da plataforma	1290x768mm
Dimensões da plataforma alargada	1400x768mm
Tempo de elevação (sem carga)	24s
Tempo de descida (sem carga)	140s
Incluindo o suporte	Si/Yes
Peso	418,00Kg
Dimensões (CxLxA)	1840x770x650mm

54564

5.511,00€

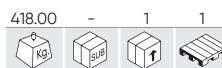

ELEVADOR PARA MONTAGEM DE BATERIAS EM VEÍCULOS ELÉCTRICOS SEM SUPORTES 1200KG



REPOSIÇÕES DISPONÍVEIS



Capacidade	1200Kg
Altura máxima de elevação	1840mm
Altura mínima de elevação	650mm
Dimensões da plataforma	1290x768mm
Dimensões da plataforma alargada	1400x768mm
Tempo de elevação (sem carga)	24s
Tempo de descida (sem carga)	140s
Incluindo o suporte	No
Peso	418,00Kg
Dimensões (CxLxA)	1840x770x650mm

52692

139,00€

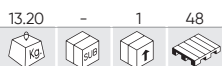

MESA PARA MOTAS 500KG



Capacidade	500Kg
Altura mínima	95mm
Altura máxima	400mm
Peso	13,20Kg
Dimensões (CxLxA)	540x350x100mm

50911

840,00€



MESA HIDRÁULICA PARA MOTAS 365KG



REPOSIÇÕES DISPONÍVEIS



Capacidade	365Kg
Altura mínima	205mm
Altura máxima	780mm
Peso	135Kg
Dimensões (CxA)	2200x490mm

53246

1.198,00€

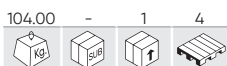

MESA HIDRÁULICA 360KG



Capacidade	360Kg
Altura mínima	360mm
Altura máxima	1290mm
Peso	104,00Kg
Dimensões (CxLxA)	712x500x1290mm

50630

590,00€

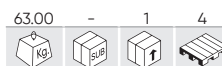

MESA ELEVADORA PARA MOTAS 400KG



REPOSIÇÕES DISPONÍVEIS



Capacidade	400Kg
Altura mínima	290mm
Altura máxima	780mm
Peso	63,00Kg
Dimensões (CxLxA)	840x480x780mm

BASE DE ELEVADOR DE GOMA PARA ELEVADOR

54349 8,00€

0.48 - 10 2040

A 160mm
B 120mm
C 20mm

54350 15,00€

0.67 - 10 1248

A 160mm
B 120mm
C 30mm

54351 16,50€

0.97 - 10 928

A 160mm
B 120mm
C 40mm

54352 18,00€

1.43 - 10 640

A 160mm
B 120mm
C 60mm

54353 25,00€

1.85 - 10 360

A 160mm
B 120mm
C 80mm

54354 37,00€

2.91 - 10 256

A 160mm
B 120mm
C 120mm

54483 16,00€

0.70 - 10 1440

A 120mm
B 120mm
C 35mm

54484 30,50€

1.75 - 10 520

A 160mm
B 120mm
C 70mm

54485 42,00€

2.40 - 10 368

A 160mm
B 120mm
C 100mm

54355 12,00€

0.20 - 10 3240

RAVAGLIOLI/SIRIO/SPACE
A 123mm **D** 108mm
B 26mm **E** 10mm
C 104mm

54360 16,50€

0.19 - 10 3888

RAVAGLIOLI/SIRIO/SPACE
A 130mm **D** 125mm
B 23mm **E** 10mm
C 121mm

54486 11,00€

0.10 - 10 6480

RAVAGLIOLI/SIRIO/SPACE
A 100mm **D** 85mm
B 22mm **E** 8,5mm
C 81mm

54488 17,00€

0.26 - 10 2160

RAVAGLIOLI
A 150mm **D** 135mm
B 25mm **E** 10mm
C 128mm

54493 15,50€

0.19 - 10 3240

RAVAGLIOLI
A 120mm
B 110mm
C 27mm

54494 17,00€

0.30 - 10 2592

RAVAGLIOLI
A 145mm
B 135mm
C 26mm

54357 18,50€

0.29 - 10 3240

TWIN BUSCH
A 120mm **D** 105mm
B 30mm **E** 8,5mm
C 100mm **F** 66mm

54358 22,50€

0.36 - 44 2376

TWIN BUSCH
A 140mm **D** 123mm
B 30mm **E** 10mm
C 115mm **F** 50mm

54361 17,00€

0.25 - 52 2808

TWIN BUSCH
A 140mm **D** 125mm
B 28mm **E** 8mm
C 120mm

54363 17,00€

0.30 - 10 2376

ISTOBAL/VELYEN
A 155mm **D** 147mm
B 24mm **E** 6mm
C 140mm

54365 12,50€

0.20 - 10 4970

ISTOBAL/VELYEN
A 145mm
B 10mm
C 60mm

BASE DE ELEVADOR DE GOMA PARA ELEVADOR

54359 14,00€

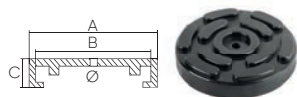

OMCN

- A 140mm
- B 133mm
- C 27mm

54491 20,50€

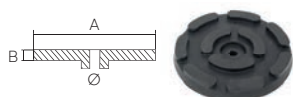
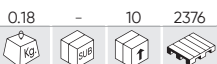

OMCN

- A 145mm
- B 25mm

54366 22,50€

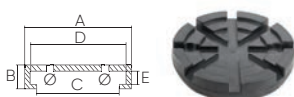
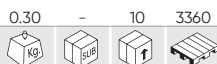

NASSBAUM/AMI

- A 125mm D 120mm
- B 24mm
- C 90mm

54362 17,00€

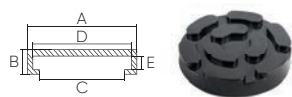
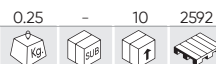

CASCOS

- A 138mm D 130mm
- B 25mm E 9mm
- C 120mm

54487 17,00€

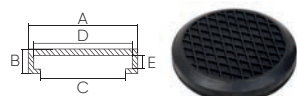

ROTARY

- A 123mm D 112mm
- B 22mm E 8mm
- C 90,5mm

54495 21,50€

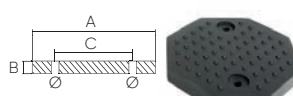

ROTARY

- A 125mm
- B 15mm
- C 90mm

54496 20,50€

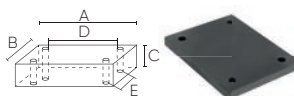

ROTARY

- A 104mm D 80mm
- B 82mm E 56mm
- C 8mm

54497 15,50€

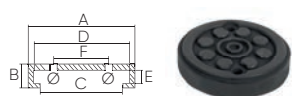

MAHA

- A 120mm D 113mm
- B 22mm E 8mm
- C 102mm F 83mm

54492 22,50€

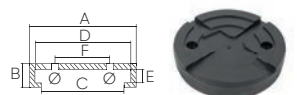

SLIFT/IME

- A 125mm D 110mm
- B 25mm E 9mm
- C 102mm F 83mm

54356 23,00€

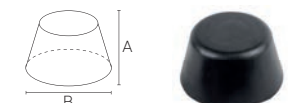

500E/500X/ JEEP RENEGADE

- A 55mm
- B 100mm

54364 16,50€

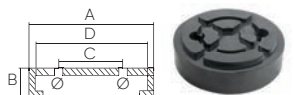

LAUNCH/TWIN BUSCH/RP TOOLS

- A 120mm D 108mm
- B 32mm
- C 70mm

54489 22,50€

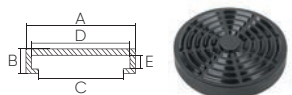

KONI/ROMERICO/CAR-O-LINER

- A 160mm D 153mm
- B 29mm E 10mm
- C 140mm

54490 15,00€

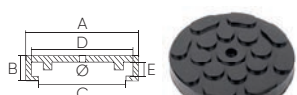

ATH/HOFMANN/
HERMANN/ J.A.B. BECKER

- A 120mm D 110mm
- B 19mm E 4mm
- C 103mm

54761 56,50€

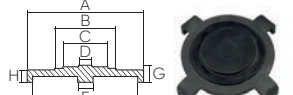

TESLA

- A 130mm E 20mm
- B 80mm F 120mm
- C 58mm G 30mm
- D 17mm H 16mm

54762 59,00€

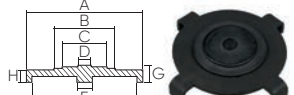
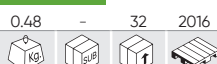

TESLA

- A 150mm E 20mm
- B 80mm F 140mm
- C 58mm G 30mm
- D 17mm H 16mm

54763 60,50€

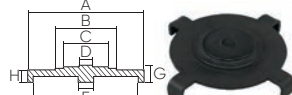

TESLA

- A 170mm E 20mm
- B 80mm F 160mm
- C 58mm G 30mm
- D 17mm H 16mm

54175

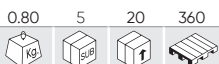

CONJUNTO DE 4 BASES DE ELEVACÃO TESLA

Marcas	Tesla 3/Y/S/X
Peso	0,80Kg
Dimensões (CxLxA)	200x200x60mm



34,00€



FERRAMENTAS ELÉTRICAS

368 ARRANCADOR

369 MANUTENÇÃO DE BATERIAS

370 MEDIÇÃO DE CORRENTE

372 INSPEÇÃO VISUAL

374 SOLDADORA

376 EQUIPAMENTO PARA OFICINA

381 CLIMATIZAÇÃO

383 TERMÓMETROS

383 OUTROS



CABOS DE ARRANQUE

PINÇA MACIÇA DE LATÃO

REF.	Ø CABO	LONGO	AH	V					€
51238	14mm	5m	700Ah	12-24V	4.95	-	2	84	138,00€
51239	15mm	7m	700Ah	12-24V	5.90	-	2	78	169,00€



PINÇA DE FERRO COBREADO

REF.	Ø CABO	LONGO	AH	V					€
52069	12mm	2,5m	250Ah	12V	1.55	-	10	45	29,50€
52070	12mm	3m	350Ah	12V	1.95	-	5	120	40,00€
52071	12mm	3m	500Ah	12V	2.35	-	5	62	47,00€



PINÇA MACIÇA DE LATÃO COM PROTETOR DE SOBRECARGA

REF.	Ø CABO	LONGO	AH	V					€
51363	12mm	3m	350Ah	12V	2.63	-	5	160	119,00€
51365	12mm	3m	500Ah	12V	3.10	-	5	90	124,00€



PINÇA MACISSA

REF.						€
14145	● COBRE	0.20	-	30	112	8,50€
14146	● COBRE	0.20	-	30	112	8,00€
14147	● LATÃO	0.35	-	15	162	25,50€
14148	● LATÃO	0.35	-	15	162	25,50€



14145 - 14146



14147 - 14148

53687

298,00€

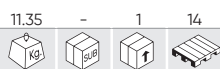

ARRANCADOR DE BATERIA 12V



VÍDEO TUTORIAL



REPOSIÇÕES DISPONÍVEIS



Tensão	12V
Bateria	22.000 mAh
Corrente de partida	750A
Corrente máxima	1500A
Peso	11,35Kg
Dimensões (CxLxA)	392x209x370mm

53688

495,00€



ARRANCADOR DE BATERIAS 12/24V



VÍDEO TUTORIAL



REPOSIÇÕES DISPONÍVEIS



Tensão	12-24V
Bateria	22.000 mAh
Corrente máxima (12V)	1500-3000A
Corrente máxima (24V)	750-1500A
Peso	18,05Kg
Dimensões (CxLxA)	392x209x370mm

55019 299,00€

1.50 - 4 80 **NEW**

ARRANCADOR DE VEÍCULOS MULTIFUNÇÕES COM ECRÃ DIGITAL E BATERIA DE LÍTIO DE 16.000MAH – 12V



Tensão	12V
Bateria	16.000mAh
Corrente de partida	650A
Corrente de pico máximo	2100A
Peso	1,50Kg
Dimensões (CxLxA)	250x100x240mm

55020 580,00€

5.50 - 1 36 **NEW**

ARRANCADOR DE VEÍCULOS MULTIFUNÇÕES COM ECRÃ DIGITAL E BATERIAS DE LÍTIO DE 48.000MAH – 12V/24V



Tensão	12/24V
Bateria	48.000 mAh
Corrente máxima (12V)	1200A-3000A
Corrente máxima (24V)	600-1500A
Peso	5,50Kg
Dimensões (CxLxA)	345x368x131 mm

53927 69,00€

0.65 5 20 240

CARREGADORE DE BATERIA 6/12V



Tensão máxima de entrada	100-200V
Tensão máxima de saída	7,2V
Potência	60W
Corrente de carga máxima	3,6A
Corrente de carga mínima	0,9A
Temperatura de trabalho	0/40°C
Comprimento do cabo de entrada	1,5m
Comprimento do cabo de saída	1,5m
Tipo	Carga automática/Automatic charge
Compatível com	Baterias/Batteries 6-12V
Peso	0,65Kg

53929 95,00€

0.90 5 20 240

CARREGADORE DE BATERIA 12/24V



Tensão máxima de entrada	100-240V
Tensão máxima de saída	14,4-14,7V
Potência	150W
Corrente de carga máxima	7,2A
Corrente de carga mínima	3,6A
Temperatura de trabalho	-20/40°C
Comprimento do cabo de entrada	1,8m
Comprimento do cabo de saída	1,5m
Tipo	Carga automática/Automatic charge
Compatível com	Baterias/Batteries 12-24V
Peso	0,90Kg

55017 890,00€

10.00 - 2 200 **NEW**

CARREGADOR INTELIGENTE DE BATERIAS 12V



Tensão	12V
Corrente de partida	150A
Proteção	IP20
Potência	1650W
Corrente de carga máxima	10-150A
Peso	10,00Kg
Dimensões (CxLxA)	420x330x125mm

55017 890,00€



52884

79,00€

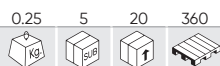

ARMAZENAMENTO DE MEMÓRIA PARA A SUBSTITUIÇÃO DAS BATERIAS

Compatível com	Baterias/Batteries 12V
Comprimento do cabo	2070mm (+/- 20mm)
Comprimento da conexão do queimador	235mm (+/- 20mm)
Peso	0,25Kg



51816

58,00€

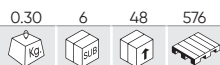

COMPROVADOR DE BATERIAS DIGITAL



Compatível com	Baterias/Batteries 12V
Peso	0,30Kg
Dimensões (CxLxA)	70x18x120mm

51235

49,00€

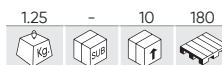

COMPROVADOR DE BATERIAS



Compatível com	Baterias/Batteries 6-12V
Peso	1,25Kg
Dimensões (CxLxA)	330x170x90mm

52233

348,00€



COMPROVADOR DE BATERIAS E ALTERNADORES COM IMPRESSORA

Bateria	AGM, VRLA, GEL, SLI
Aplicável	12, 24V
Faixa	40-2000CCA (SAE)
Comprimento do cabo	1800mm
Peso	2,32Kg
Dimensões (CxLxA)	250x62x42mm



CONTÉM
x1 Rolo de papel térmico



REPOSIÇÕES DISPONÍVEIS



54040

240,00€

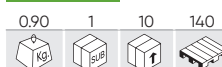

COMPROVADOR DE BATERIA COM IMPRESSORA

Bateria	AGM, GEL, VRLA, SLI
Aplicável	12, 24V
Faixa	100-2000CCA (SAE)
Comprimento do cabo	550mm
Peso	0,90Kg
Dimensões (CxLxA)	87x48x180mm



REPOSIÇÕES DISPONÍVEIS

CONTÉM
x2 Rolo de papel térmico
x1 Bateria CR2032



54557

78,00€



DETECTOR DE TENSÃO



Tensão	12-1000V
Frequência	40-400Hz
Temperatura de trabalho	-10/55°C
Peso	0,40Kg
Dimensões (CxLxA)	73x34x268mm

54559

18,60€

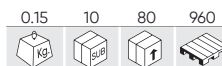

DETECTOR DE TENSÃO SEM CONTACTO



Tensão	50-1000V
Frequência	50-60Hz
Temperatura de trabalho	0/50°C
Peso	0,15Kg
Dimensões (CxLxA)	143x25x21mm

COMPROVADOR DE CIRCUITOS

REF.	V	mm					€
53028	6, 12, 24V	1.8x190mm	0.70	10	120	1440	5,80€
53029	6, 12, 24V	2x115mm	0.08	12	240	2400	6,80€
53030	6, 12, 24V	3x142mm	0.17	6	60	720	12,00€



53028

53029

53030

54114

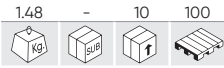

MEDIDOR DE ISOLAMENTO

Tensão	AC / DC
Medição de voltagem em corrente alternada (AC)	0-750V
Medição de voltagem em corrente contínua (DC)	0-1000V
Medição de resistência (Ω)	0-200Ω, 200-2000Ω, 0-200mΩ, 200-2000mΩ
Ambiente operacional	0°C/40°C
Ambiente de armazenamento	-10°C/60°C
Bateria	6 Pilas/Batteries AA
Categoria de medição	CAT III
Categoria de instalação	2
Peso	1,48Kg
Dimensões (CxLxA)	200x92x55mm

248,00€



53209

8,50€

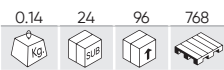

DENSÍMETRO DE BATERIAS

Compatível com	Baterias/Batteries 6-12-24V
Comprimento	270mm
Peso	0,14Kg



54256

54,00€

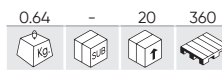

PROTECTOR DE PICOS AUTOMÁTICO 12/24V

Tensão	12-24V
Tensão máxima DC	35V
Corrente de pico máximo	800Amps
Máxima absorção	1500W
Peso	0,64Kg



52231

53,00€

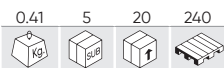

KIT DE ACESSÓRIOS PARA MULTÍMETRO

CONTÉM	
x2	Sondas
x2	Pinças pequenas
x2	Pinças largas
113cm	Cabos de extensão



52439

227,00€

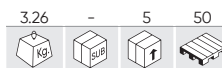

JOGO DE CABOS E ACC PARA MULTÍMETRO

CONTÉM	
x2	Medidores de resistência variável
x2	Luzes led de comprovação
x2	SRS substituição e dois dispositivos de proba
x2	Alicates de crocodilo
x2	Tomas de engate rápido
x4	Sondas
x24	Conectores redondos
x48	Conectores lisos



52382

19,50€

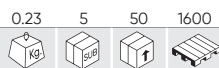

PINÇA AMPERIMÉTRICA

DCB	600V
ACB	600V
DCA	-
ACA	20A, 200A, 600A
OHM	2KΩ, 200KΩ, 2MΩ



Tensão	AC / DC
Ambiente de armazenamento	0°C/40°C
Ambiente operacional	-10°C/40°C
Bateria	2 Pilas/Batteries AAA
Peso	0,23Kg
Dimensões (CxLxA)	167x55x22mm

52952

74,00€

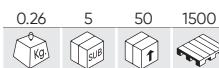

PINÇA AMPERIMÉTRICA PROFESIONAL

DCB	20V, 600V
ACB	600V
DCA	200A
ACA	200A
OHM	2000Ω



Tensão	AC / DC
Ambiente operacional	0°C/40°C
Ambiente de armazenamento	-10°C/40°C
Bateria	2 Pilas/Batteries AAA
Peso	0,26Kg
Dimensões (CxLxA)	175x53x25mm

50942

28,00€

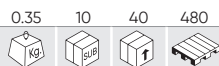

MULTÍMETRO DIGITAL

Medição de voltagem em corrente alternada (AC)	200mV, 2V, 20V, 200V, 1000V
Medição de voltagem em corrente contínua (DC)	200mV, 2V, 20V, 200V, 750V
Medição de intensidade de corrente alternada (AC)	20mA, 200mA, 20A
Medição de intensidade de corrente contínua (DC)	20mA, 200mA, 20A
Medição de resistência (Ω)	200Ω, 2KΩ, 20KΩ, 200KΩ, 2MΩ, 20MΩ, 2000MΩ
Medição de capacitância (F)	2nF, 20nF, 200nF, 2μF, 20μF, 200μF
Temperatura de trabalho	-40°C /1000 °C
Peso	0,35Kg
Dimensões (CxLxA)	190x90x33mm



54706

58,00€

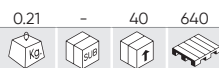

ENDOSCÓPIO COM WIFI

Quadros	25FPS
Comprimento do cabo	1m
Diâmetro da câmara	8mm
Gama de focagem	70°
Proteção IP	IP67
Capacidade da bateria	850mAh
Tempo de trabalho	2,5h
Tempo de carregamento	1,5h
Compatível com	iOS, Android
Ângulo de visão	70°
Brilho	24Lm



VÍDEO TUTORIAL



Tipo de carga	TYPE-C
Medidas da cabeceira	41x8mm
Peso	0,210Kg
Dimensões (CxXa)	98,5x38,5mm

53484

579,00€

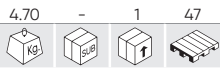

DETECTOR DE VAZAMENTO DE GÁS 16L/MIN



VÍDEO TUTORIAL



REPOSIÇÕES DISPONÍVEIS



Tensão	12V
Caudal	16L/min
Pressão de ensaio	15PSI
Peso	4,70Kg
Dimensões (CxLxA)	275x220x265mm

54524

298,00€



DETECTOR DE VAZAMENTO DE FUMAÇA 8L/ MIN



VÍDEO TUTORIAL



REPOSIÇÕES DISPONÍVEIS



Tensão	12V
Caudal	8L/min
Pressão de ensaio	15PSI
Peso	3,32Kg
Dimensões (CxLxA)	195x125x125mm

54685

105,00€

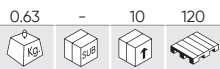

DETECTOR DE FUGAS POR ULTRASSONS



REPOSIÇÕES DISPONÍVEIS



VÍDEO TUTORIAL

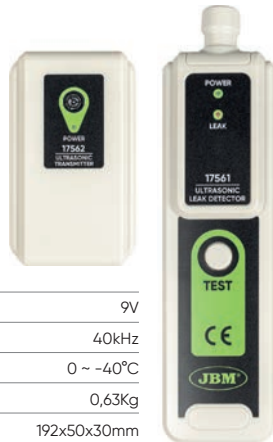

Tensão	9V
Frequência das ondas ultra-sónicas	40kHz
Temperatura de trabalho	0 ~ -40°C
Peso	0,63Kg
Dimensões (CxLxA)	192x50x30mm

14081

11,90€

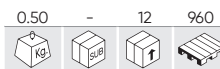

ÓLEO PARA MÁQUINA DETECÇÃO POR FUMO



Capacidade	500ml
Compatível com	53484
Peso	0,50Kg

54707

437,00€

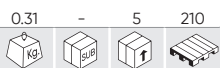

CÂMARA DE TERMOGRAFIA

Tela	2,4 LCD TFT
Resolução	320x240px
Emissividade	0,01~0,99LCD
Precisão	±2°C
Faixa	-20/400°C
Distância focal	0,1m
Visualização	6 Filtros/Filters
Bateria	Li-ion 3.7V/2600mAh 18650
Porta de carga	USB C
Peso	0,31Kg
Dimensões (CxLxA)	197x72x60mm



VÍDEO TUTORIAL



93,00€

54561

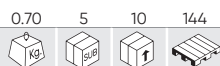

SOLDADOR DE PLÁSTICO PARA REPARAÇÃO DE CARROÇARIAS

Tensão nominal	3,7V
Potência	18W
Bateria	2600mAh Li-ion
Inclui	200 Grapas/Staples
Tempo de carregamento	3H
Tempo de trabalho	200-500 Grapadas/Staples
Carregador	Tipo C/ Type C
Temperatura de trabalho	500°C
Peso	0,70Kg
Dimensões (CxLxA)	200x27x50mm



53145

43,00€



PISTOLA DE CALOR 1600W



Tensão	220-240V
Potência	1600W
Frequência	50-60Hz
Temperatura de trabalho	400/600°C
Taxa de fluxo de ar	250-550L/min
Peso	0,95Kg

53162

70,00€



PISTOLA DE CALOR DIGITAL 2000W



Tensão	220-240V
Potência	2000W
Frequência	50-60Hz
Temperatura de trabalho	100/600°C
Taxa de fluxo de ar	280-480L/min
Peso	0,80Kg

53977

17,50€

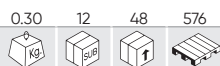

SOLDADOR 40W



Tensão	220-240V
Potência	40W
Frequência	50Hz
Temperatura de trabalho	450°+/-10%
Comprimento	240mm
Comprimento do cabo	1,3m

53111

19,30€



MAÇARICO DE SOLDA 100W



Tensão	220-240V
Potência	100W
Frequência	50Hz
Temperatura de trabalho	420°+/-10%
Comprimento	250mm
Comprimento do cabo	1,5m

53981

149,00€

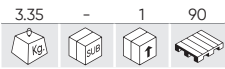

DISPOSITIVO PARA SOLDAGEM A ARCO ELÉTRICO MANUAL COM INVERSOR CC 100 A



REPOSIÇÕES DISPONÍVEIS



Tensão	230V
Frequência	50Hz
Potência	3,7KVA
Intensidade	16A
Tensão em vazio	65V
Tensão máxima de saída	24V
Fator de utilização	15%
Fator de potência	0,7
Eficiência	85%
Eletrodo	1,0 - 3,2mm
Classe de isolamento	F
Classe de proteção	IP21S
Peso	3,35Kg
Dimensões (CxLxA)	200x80x130mm

53982

219,00€



SOLDADORA INVERTER MMA 160A DC



REPOSIÇÕES DISPONÍVEIS



Tensão	230V
Frequência	50-60Hz
Potência	6,5KVA
Intensidade	29A
Tensão em vazio	65V
Tensão máxima de saída	26,4V
Fator de utilização	35%
Fator de potência	0,7
Eficiência	85%
Eletrodo	1,0 - 4,0mm
Classe de isolamento	F
Classe de proteção	IP21S
Peso	6,10Kg
Dimensões (CxLxA)	330x140x260mm

ESQUADRO MAGNÉTICO

REF.	mm	°						€
54111	75mm	45, 90, 135°	0.35	10	40	1680	5,00€	
54113	100mm	45, 90, 135°	0.60	10	20	1100	8,50€	



53414

49,00€

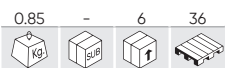

CAPACETE PARA SOLDAGEM COM REGULADOR MANUAL



BOTÃO ANALÓGICO PARA AJUSTAR A SENSIBILIDADE E ESCURECIMENTO

53415

188,00€



CAPACETE PARA SOLDAGEM COM REGULADOR DIGITAL



REGULADOR DIGITAL

54482

698,00€

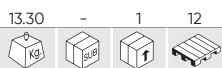

LIMPADOR ULTRASSÔNICO 30L



REPOSIÇÕES DISPONÍVEIS



Tensão	200-240V
Potência	500-600W
Frequência	50Hz
Frequência das ondas ultra-sônicas	40KHZ
Capacidade do depósito	30L
Número de transdutores	10
Temporizador	1-60min
Temperatura de trabalho	0/80°C
Peso	14,50Kg
Dimensões do depósito	500x300x200mm
Dimensões (CxLxA)	555x325x335mm

54733

3.360,00€

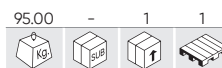

LIMPADOR ULTRASSÔNICO 53L



REPOSIÇÕES DISPONÍVEIS



Tensão	110-220V
Potência	900-1500W
Frequência	50Hz
Frequência das ondas ultra-sônicas	40KHZ
Capacidade do depósito	53L
Número de transdutores	18
Temporizador	1-99min
Temperatura de trabalho	20/95°C
Peso	95,00Kg
Dimensões do depósito	500x350x300mm
Dimensões (CxLxA)	665x515x600mm

17605

179,00€



LÍQUIDO DE LIMPEZA POR ULTRA-SONS

Compatível com	54482, 54733
Capacidade	20L
Peso	23,00Kg
Dimensões (CxLxA)	280x240x410mm



54795 **49,00€**

0.18 - 10 1200 **NEW**

MÁQUINA DE DIAGNÓSTICO MULTIMARCA - OBDII/EOBD PARA VEÍCULOS



Tela	128x64px
Temperatura de trabalho	0~60°C (32~140F°)
Alimentação	8.0~18.0V
Conectores	OBD II
Dimensões (CxLxA)	108x74x20mm
Peso	0,30Kg

53660 **159,00€**

8.60 - 1 27

BASE METÁLICA PARA AMOLADORA DE BANCADA



Altura	790mm
Medidas da bandeja superior	250x280mm
Compatível com	52195

53656 **198,00€**

11.05 - 1 50

AMOLADORA DUPLA ELÉCTRICA 450W





REPOSIÇÕES DISPONÍVEIS

Tensão	230V
Potência	450W
Frequência	50Hz
Velocidade	2950RPM
Tamanho da mó	150x20x12,7mm

53657 **259,00€**

16.35 - 1 24

AMOLADORA DUPLA ELÉCTRICA 600W



REPOSIÇÕES DISPONÍVEIS

Tensão	230V
Potência	600W
Frequência	50Hz
Velocidade	2950RPM
Tamanho da mó	200x25x15,88mm

53658 **99,00€**

6.95 - 1 60

AMOLADORA DUPLA ELÉCTRICA 250W



REPOSIÇÕES DISPONÍVEIS

Tensão	230V
Potência	250W
Frequência	50Hz
Velocidade	2950RPM
Tamanho da mó	150x20x12,7mm

53659 **121,00€**

9.70 - 1 15

AMOLADORA DUPLA ELÉCTRICA 250W



REPOSIÇÕES DISPONÍVEIS

Tensão	230V
Potência	250W
Frequência	50Hz
Velocidade	2950RPM
Tamanho da mó	150x20x12,7mm/200x40x20mm

NEW

ESMERILHADEIRA ANGULAR ELÉTRICA PROFISSIONAL

REF.	V	Hz	W	Ø	RPM					€
54872	220-230V	50Hz	750W	115mm	11000RPM	2.25	-	4	144	80,00€
54753	230V	50/60Hz	1400W	125mm	10500RPM	3.00	-	4	144	130,00€
54883	220-230V	50Hz	2400W	230mm	6500RPM	6.75	-	2	48	198,00€



54872



REPOSIÇÕES DISPONÍVEIS



54753



REPOSIÇÕES DISPONÍVEIS



54883



REPOSIÇÕES DISPONÍVEIS



VÍDEO TUTORIAL

54512

586,00€

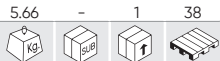

AQUECEDOR DE INDUÇÃO 1KW



REPOSIÇÕES DISPONÍVEIS

Potência	1KW
Frequência	50Hz
Consumo de energia	4,16A
Potência de saída	0,8KVA
Fator de carga	0,58-0,975KVA
Proteção IP	IP20
Comprimento do cabo	1000mm
Comprimento do alargamento da indução	700mm
Peso	5,66Kg
Dimensões (CxLxA)	365x67x70mm

54522

1.299,00€



AQUECEDOR DE INDUÇÃO 1.5KW



REPOSIÇÕES DISPONÍVEIS

Potência	1,5W
Frequência	50-60Hz
Consumo de energia	8A
Potência de saída	3,2KVA
Fator de carga	0,95KVA
Proteção IP	IP20
Comprimento do cabo	1000mm
Comprimento do alargamento da indução	700mm
Peso	5,25Kg
Dimensões (CxLxA)	200x140x75mm

54342

858,00€

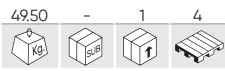

MÁQUINA LIMPADORA DE PEÇAS COM TERMÓSTATO 14L

Capacidade do depósito	8-14L
Taxa de fluxo de ar	70-120PSI
Caudal de recirculação do agente de lavagem	0,8L/min
Temperatura máxima do termóstato	50°C
Temperatura de saída	35°C
Peso	49,50Kg
Dimensões do depósito	740x560x452mm
Dimensões (CxLxA)	790x1260x610mm



REPOSIÇÕES DISPONÍVEIS VÍDEO TUTORIAL

52980

498,00€

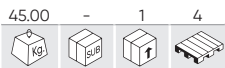

MÁQUINA DE LIMPEZA DE PEÇAS 150L



REPOSIÇÕES DISPONÍVEIS



Capacidade do tanque	90L
Taxa de entrega	2,7 - 3,6 L/min
Peso	42,00Kg
Dimensões do depósito	1060x490x270mm
Dimensões (CxLxA)	1090x540x890mm

50632

298,00€

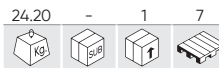

MÁQUINA DE LIMPEZA DE PEÇAS 80L



REPOSIÇÕES DISPONÍVEIS



Capacidade do tanque	45L
Taxa de entrega	2,7 - 3,6 L/min
Peso	23,20Kg
Dimensões do depósito	710x480x256mm
Dimensões (CxLxA)	760x540x880mm

16872

79,00€



LÍQUIDO DETERGENTE PARA LIMPEZA DE PEÇAS MECÂNICAS (20L)

Compatível com	54342, 52980, 50632
Capacidade	20L
Peso	21,40Kg
Dimensões (CxLxA)	280x240x410mm



51837

198,00€

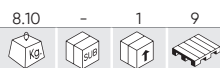

ASPIRADOR INDUSTRIAL - SECO DE 30L



REPOSIÇÕES DISPONÍVEIS

Tensão	230V
Potência	1200W
Frequência	50Hz
Capacidade	30L
Litros de sucção por segundo	26L/s
Potência de sucção	17KPa
Proteção IP	IPX4
Comprimento da mangueira	1,5m
Comprimento do cabo	4,5m
Peso	8,25Kg

51838

690,00€



ASPIRADOR INDUSTRIAL DE 80L (SECO E HÚMEDO)



REPOSIÇÕES DISPONÍVEIS

Tensão	230V
Potência	1000W
Frequência	50Hz
Capacidade	80L
Litros de sucção por segundo	50L/s
Potência de sucção	20KPa
Proteção IP	IPX4
Comprimento da mangueira	2m
Comprimento do cabo	4,5m
Peso	28,00Kg

54771

279,00€

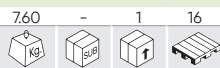

NEW

ASPIRADOR PARA ESTOFOS 20L (SECO+HÚMEDO)



VIDEO TUTORIAL



REPOSIÇÕES DISPONÍVEIS

Tensão	230V
Potência	1200W
Frequência	50Hz
Capacidade	20L
Litros de sucção por segundo	26L/s
Intensidade do som	82dB
Potência de sucção	17-18KPa
Proteção IP	4
Dimensões (CxLxA)	390x340x460mm
Peso	7,60Kg



53947

149,00€

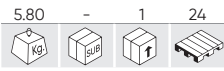

LAVADORA DE ALTA PRESSÃO 1400W



REPOSIÇÕES
DISPONÍVEIS

Tensão	230V
Potência	1400W
Frequência	50Hz
Pressão do trabalho	70-105BAR
Fluxo máximo de operação	5,5-6,8L/min
Temperatura de trabalho	50°C
Proteção IP	IPX5
Peso	5,80Kg
Dimensões (CxLxA)	280x255x440mm

53948

324,00€



LAVADORA DE ALTA PRESSÃO 2400W



REPOSIÇÕES
DISPONÍVEIS

Tensão	230V
Potência	2400W
Frequência	50Hz
Pressão do trabalho	120-180BAR
Fluxo máximo de operação	5,5-8L/min
Temperatura de trabalho	50°C
Proteção IP	IPX5
Peso	12,10Kg
Dimensões (CxLxA)	440x345x505mm

54229

48,00€

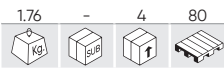

AQUECEDOR 2KW



54230

68,00€

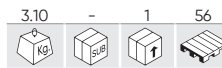

AQUECEDOR 3KW



54231

138,00€

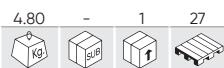

AQUECEDOR 5KW



54232

248,00€



AQUECEDOR 9KW

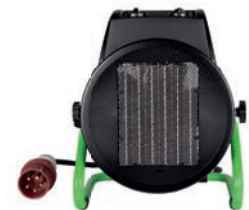

	54229	54230	54231	54232
Tensão	220-240V	220-240V	380-400V	380-400V
Potência	1000-2000W	1500-3000W	3300-5000W	6000-9000W
Frequência	50Hz	50Hz	50Hz	50Hz
Área de aquecimento	20m2	30m2	48m2	80m2
Saída de ar	197m2/h	280m2/h	588m2/h	1180m2/h
Material	SPCC	SPCC	SPCC	SPCC
Peso	1,76Kg	3,10Kg	4,80Kg	7,90Kg
Dimensões (CxLxA)	210x160x217mm	265x210x290mm	300x235x345mm	395x307x455mm

53543

13,80€

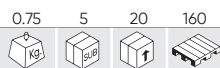

VENTILADOR DE VEÍCULO - 12 V

Tensão	12V
Potência	120W
Frequência	50Hz
Velocidades	2700-3100RPM/min
Peso	0,75Kg
Dimensões (CxLxA)	180x175x165mm



53190

98,00€

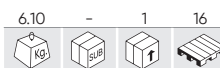

VENTILADOR DE CHÃO 120W

Tensão	230V
Potência	120W
Frequência	50Hz
Velocidades	1050, 1150, 1300RPM/min
Peso	6,10Kg
Dimensões (CxLxA)	230x620x575mm



54125

152,00€

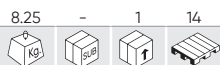

VENTILADOR NEBULIZADOR DE ÁGUA 75W

Tensão	220-240V
Potência	75W
Frequência	50Hz
Velocidades	3
Capacidade	3,2L
Consumo de água	<220ml/h
Peso	8,25Kg
Dimensões (CxLxA)	430x400x125mm



53189

128,00€



VENTILADOR DE PÉ 120W

Tensão	230V
Potência	120W
Frequência	50Hz
Velocidades	1050, 1150, 1300RPM/min
Peso	7,10Kg
Dimensões (CxLxA)	1240x400x550mm



REPOSIÇÕES DISPONÍVEIS

55023

1.380,00€

NEW

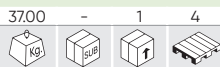

CLIMATIZADOR EVAPORATIVO MÓVEL 300W 120L

Tensão	220V
Potência	300W
Frequência	50Hz
Fluxo de ar	6800m ³ /h
Velocidades	3
Capacidade do depósito	120L
Capacidade de refrigeração	30-60m ²
Peso	37,00Kg
Dimensões (CxLxA)	860x500x1380mm



54554

484,50€



AR CONDICIONADO PORTÁTIL 2600W

Tensão	220-240V
Capacidade de desumidificação	1,0L/h
Capacidade de refrigeração	2600W
Potência de entrada	950W
Frequência	50Hz
Fluxo de ar	270m ³ /h
Espaço de aplicação	13-18m ²
Unidade de calor	9000BTU
Refrigerante	R290
Diâmetro do cabo	155mm
Comprimento do cabo	1,5m
Peso	21Kg
Dimensões (CxLxA)	330x280x685mm



REPOSIÇÕES DISPONÍVEIS

53503

12,00€

0.05 20 100 2400



TERMÔMETRO DIGITAL DE CONTATO

Bateria	Pila/Battery 1.5V
Gama de medição	-50°C/+330°C
Precisão	±1°C
Unidades de medida	°C / °F
Peso	0,05Kg



52162

38,00€

0.17 6 72 576



TERMÓMETRO LÁSER -50°C A 550°C



Tensão	9V
Gama de medição	-50/550°C
Precisão	±2°C
Emissividade	0.1-1.0
Tempo de resposta	500ms
Peso	0,17Kg
Dimensões (CxLxA)	145x37x90mm

52450

111,00€

0.72 5 20 200



TERMÓMETRO LÁSER -50° ~1000°



Tensão	9V
Gama de medição	-50/1000°C
Precisão	±1,5°C
Emissividade	0.1-1.0
Tempo de resposta	500ms
Peso	0,72Kg
Dimensões (CxLxA)	175x105x48mm

51831

24,00€

0.35 12 36 288



PISTOLA DE COLA TERMOFUSÍVEL



REPOSIÇÕES DISPONÍVEIS



Tensão	100-200V
Potência	60-150W
Temperatura de trabalho	190/230°C
Diâmetro do bocal	2,3mm
Peso	0,35Kg

51033

89,00€

3.86 1 2 42



EXTENÇÃO MANUAL DE CABO ELÉCTRICO 25M



Tensão	300V
Potência	1.110-3.200W
Comprimento do cabo	25m
Proteção IP	IP20
Cabo	HO5W-F 3X1,5 mm ² (PVC)
Peso	3,86Kg
Dimensões (CxLxA)	320x230x155mm

EXTENSÃO DE CORRENTE ELÉTRICA

REF.	m					€
53166	3m	0.45	5	30	600	11,30€
53167	5m	0.65	5	20	600	13,90€
53168	10m	1.20	-	10	300	31,00€



53585

168,00€

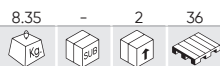

CARRETEL DE CABO ELÉTRICO 21M - AZUL



REPOSIÇÕES DISPONÍVEIS

Tensão	230V
Potência	1500-3000W
Comprimento	20+1M
Proteção IP	IP44
Cabo	H07RN-F3G1.5mm2
Peso	16,00Kg
Dimensões (CxLxA)	320x205x340mm

53586

168,00€

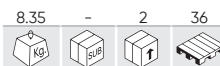

CARRETEL DE CABO ELÉTRICO 21M - VERDE



REPOSIÇÕES DISPONÍVEIS

Tensão	230V
Potência	1500-3000W
Comprimento	20+1M
Proteção IP	IP44
Cabo	H07RN-F3G1.5mm2
Peso	16,00Kg
Dimensões (CxLxA)	320x205x340mm

53526

119,00€



CARRETEL DE CABO ELÉTRICO 12M - AZUL



REPOSIÇÕES DISPONÍVEIS

Tensão	230V
Potência	1500-3000W
Comprimento	11+1M
Proteção IP	IP44
Cabo	H07RN-F3G1.5mm2
Peso	18,00Kg
Dimensões (CxLxA)	330x170x300mm

53584

119,00€



CARRETEL DE CABO ELÉTRICO - 12M - VERDE



REPOSIÇÕES DISPONÍVEIS

Tensão	230V
Potência	1500-3000W
Comprimento	11+1M
Proteção IP	IP44
Cabo	H07RN-F3G1.5mm2
Peso	20,00Kg
Dimensões (CxLxA)	330x170x300mm

i

- ✓ COM REPARTIDOR
- ✓ PROTEÇÃO DIFERENCIAL DE SOBRECARGA
- ✓ BLOCO DE CABO



ENERGIA RENOVÁVEL E MOBILIDADE DO FUTURO

386 CABOS PARA CARREGAR DE CARROS ELÉTRICOS

386 CARREGADORES DE CARRO ELÉTRICO

387 FERRAMENTAS COM ISOLAMENTO

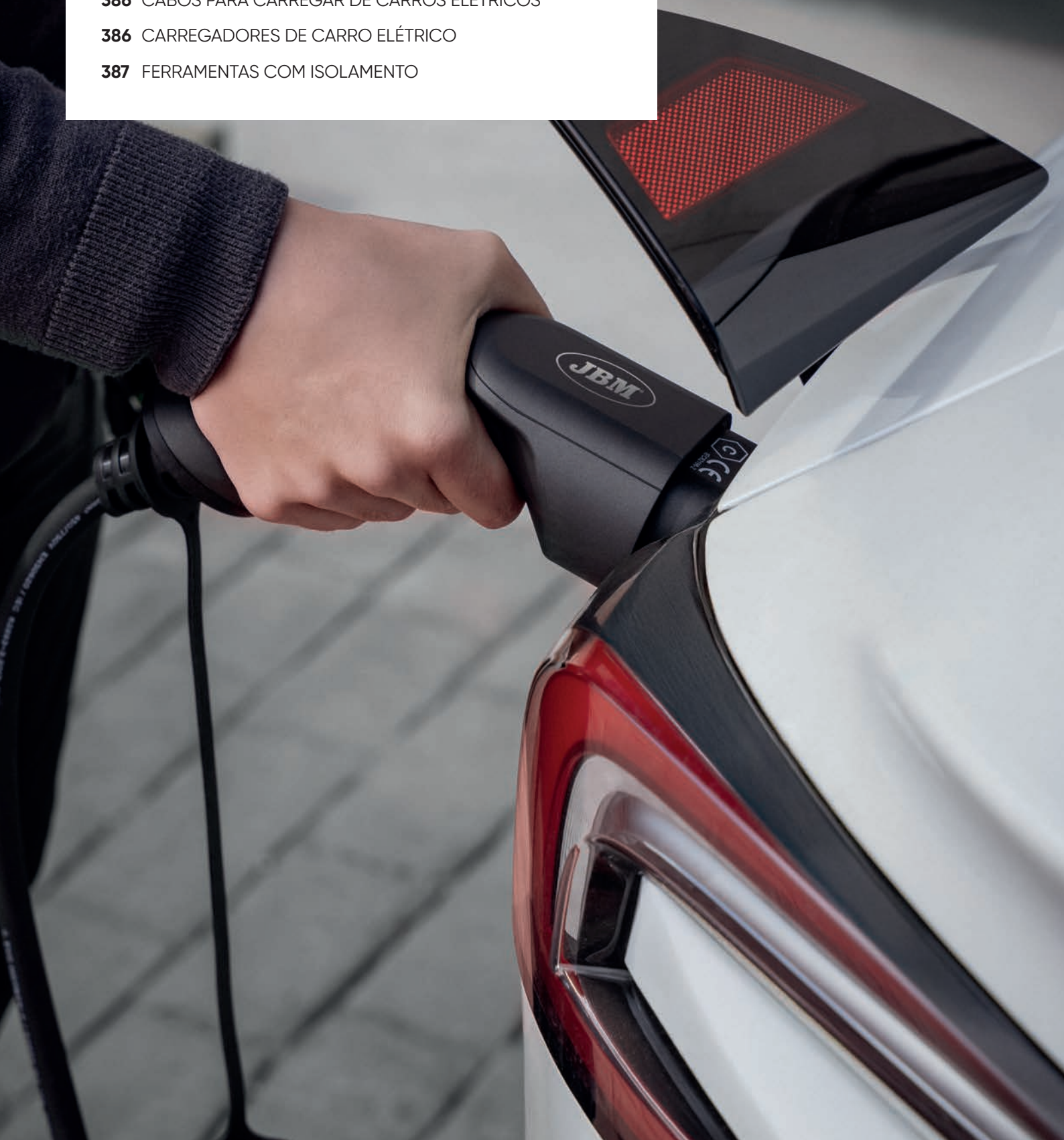

CABO DE CARREGAMENTO

REF.													€
54053	3.6KW	16A	-25° +55°	IP66	5m	TIPO 1 AO TIPO 2	SINGLE-PHASE	2.15	-	5	-		248,00€
54054	7.5KW	32A	-25° +55°	IP66	5m	TIPO 1 AO TIPO 2	SINGLE-PHASE	2.90	-	5	100		268,00€
54055	3.6KW	16A	-25° +55°	IP66	5m	TIPO 2 AO TIPO 2	SINGLE-PHASE	2.15	-	5	100		220,00€
54056	11KW	16A	-25° +55°	IP66	5m	TIPO 2 AO TIPO 2	TRIFÁSICO	2.85	-	5	102		260,00€
54057	7.5KW	32A	-25° +55°	IP66	5m	TIPO 2 AO TIPO 2	SINGLE-PHASE	2.95	-	5	90		248,00€
54058	22KW	32A	-25° +55°	IP66	5m	TIPO 2 AO TIPO 2	TRIFÁSICO	3.85	-	5	90		348,00€

TIPO 1-2 TYPE 1-2



TIPO 2-2 TYPE 2-2



17892 19,50€

0.30 - 50 200

NEW

BOLSA PARA CABO DE CARGA DE CARRO ELÉTRICO

CARREGADOR DE REDE

REF.										€		
52600	3.6KW	16A	-25° +55°	IP66		TIPO 2	SINGLE-PHASE	4.65	-	4	80	884,00€
52902	7KW	32A	-25° +55°	IP66		TIPO 2	SINGLE-PHASE	4.90	-	4	40	970,00€
52903	11KW	16A	-25° +55°	IP66		TIPO 2	TRIFÁSICO	5.25	-	1	40	1.100,00€



54265

1.290,00€

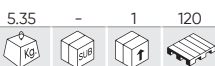

ESTAÇÃO DE CARREGAMENTO 22 KW, 32 A, PARA CARROS ELÉTRICOS (TRIFÁSICO)



REPOSIÇÕES DISPONÍVEIS

54059

428,00€



CARREGADOR PORTÁTIL 16 A MONOFÁSICO, COM CABO DE CARGA TIPO 2



REPOSIÇÕES DISPONÍVEIS

50942

28,00€

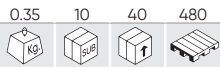

MULTÍMETRO DIGITAL

Medição de voltagem em corrente alternada (AC)	200mV, 2V, 20V, 200V, 1000V
Medição de voltagem em corrente contínua (DC)	200mV, 2V, 20V, 200V, 750V
Medição de intensidade de corrente alternada (AC)	20mA, 200mA, 20A
Medição de intensidade de corrente contínua (DC)	20mA, 200mA, 20A
Medição de resistência (Ω)	2000, 2KO, 20KO, 200KO, 2MO, 20MO, 2000MO
Medição de capacitância (F)	2nF, 20nF, 200nF, 2μF, 20μF, 200μF
Temperatura de trabalho	-40°C /1000 °C
Peso	0,35Kg
Dimensões (CxLxA)	190x90x33mm



52952

74,00€

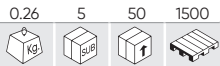

PINÇA AMPERIMÉTRICA PROFESIONAL



Tensão	AC / DC
Ambiente operacional	0°C/40°C
Ambiente de armazenamento	-10°C/40°C
Bateria	2 Pilas/Batteries AAA
Peso	0,26Kg
Dimensões (CxLxA)	175x53x25mm

52382

19,50€

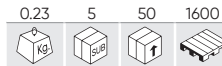

PINÇA AMPERIMÉTRICA



Tensão	AC / DC
Ambiente de armazenamento	0°C/40°C
Ambiente operacional	-10°C/40°C
Bateria	2 Pilas/Batteries AAA
Peso	0,23Kg
Dimensões (CxLxA)	167x55x22mm

54091

441,00€

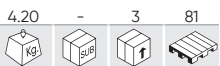

MALETA DE FERREMENTA ISOLADA - 26PEÇAS

CUMPRE COM:

- ⚡ VDE
- 🛡️ GEPRÜFTE SICHERHEIT
- ⚡ 1000V 22C IEC 60900 C



REPOSIÇÕES DISPONÍVEIS



54093

441,00€



MÓDULO EVA DE FERRAMENTA ISOLADA

CUMPRE COM:

- ⚡ VDE
- 🛡️ GEPRÜFTE SICHERHEIT
- ⚡ 1000V 22C IEC 60900 C



REPOSIÇÕES DISPONÍVEIS



53154

462,00€



MALETA DE FERRAMENTA ISOLADA 20 PEÇAS DE 3/8"

CUMPRE COM:

- VDE
- GEPRÜFTE SICHERHEIT
- 1000V 22C IEC 60900 C



54562

68,50€



CONJUNTO DE CHAVES DE FENDAS INTERCAMBIÁVEIS 25PCS ISOLADAS

CUMPRE COM:

- VDE
- GEPRÜFTE SICHERHEIT
- 1000V 22C IEC 60900 C



15162

32,50€



MÓDULO DE 8 CHAVES DE FENDAS ISOLADAS VDE

CUMPRE COM:

- VDE
- GEPRÜFTE SICHERHEIT
- 1000V 22C IEC 60900 C

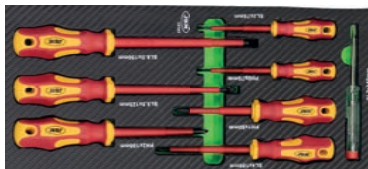

REPOSIÇÕES DISPONÍVEIS

52519

25,50€

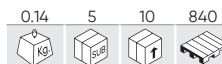

KIT DE 7 CHAVES ISOLADAS ATÉ 1.000V

CUMPRE COM:

- VDE
- GEPRÜFTE SICHERHEIT
- 1000V 22C IEC 60900 C

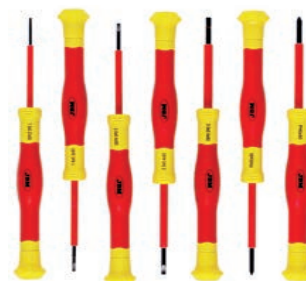

LUVAS ISOLANTES PARA TRABALHOS SOB TENSÃO

REF.	DESCRIÇÃO	kg	boxes	pieces	€	
54130	T.9	0.35	-	21	220	65,00€
54131	T.10	0.40	-	21	100	65,00€

CUMPRE COM:

- VDE / CLASS 0 / CAT III
- IEC ELECTRICAL SAFETY GLOVES 60903-2014



53165

19,60€



NAVALHA CORTA CABOS ISOLADA (CURVADA)

CUMPRE COM:

- VDE
- GEPRÜFTE SICHERHEIT
- 1000V 22C IEC 60900 C
- CERTIFICATE EN60900



54114

248,00€



MEDIDOR DE ISOLAMENTO

Tensão	AC / DC
Medição de voltagem em corrente alternada (AC)	0-750V
Medição de voltagem em corrente continua (DC)	0-1000V
Medição de resistência (Ω)	0-200Ω, 200-2000Ω, 0-200mΩ, 200-2000mΩ
Ambiente operacional	0°C/40°C
Ambiente de armazenamento	-10°C/60°C
Bateria	6 Pilas/Batteries AA
Categoria de medição	CAT III
Categoria de instalação	2
Peso	1,48Kg
Dimensões (CxLxA)	200x92x55mm



54132 190,00€

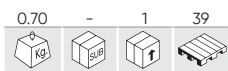

PROTEÇÃO FACIAL ISOLANTE PARA TRABALHOS SOB TENSÃO

CUMPRE COM:

- EN 170:2022
- EN 166:2001
- ANSI Z87.1
- CLASS I



Altura	205mm
Proteção	Clase I/Class I
Tipo	Tratamiento anti-vaho/Anti-fogging treatment
Peso	0,70Kg

54241 120,00€

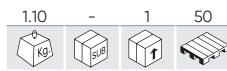

GANCHO DE RESGATE ISOLADO - 45KV



Tensão de funcionamento	45KV
Material	Fibra de vidro/Fiberglass, Resina poliéster/Polyester resin
Comprimento	1650mm
Peso	1,10Kg

54129 110,00€

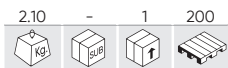

TAPETE ISOLANTE CLASSE 0

Medição de intensidade de corrente alternada (AC)	1000V
Medição de intensidade de corrente contínua (DC)	1500V
Proteção	Clase/Class 0
Peso	2,10Kg
Dimensões (CxLxA)	1000x600x2mm



CUMPRE COM:

- IEC ELECTRICAL SAFETY MATTING 61111 : 2009
- CLASS 0

54386 5.839,00€

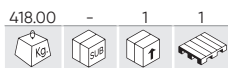

ELEVADOR PARA MONTAGEM DE BATERIAS EM VEÍCULOS ELÉCTRICOS 1200KG



REPOSIÇÕES DISPONÍVEIS



VÍDEO TUTORIAL

Capacidade	1200Kg
Altura máxima de elevação	1840mm
Altura mínima de elevação	650mm
Dimensões da plataforma	1290x768mm
Dimensões da plataforma alargada	1400x768mm
Tempo de elevação (sem carga)	24s
Tempo de descida (sem carga)	140s
Incluindo o suporte	Si/Yes
Peso	418,00Kg
Dimensões (CxLxA)	1840x770x650mm

54564 5.511,00€



ELEVADOR PARA MONTAGEM DE BATERIAS EM VEÍCULOS ELÉCTRICOS SEM SUPORTES 1200KG



REPOSIÇÕES DISPONÍVEIS

Capacidade	1200Kg
Altura máxima de elevação	1840mm
Altura mínima de elevação	650mm
Dimensões da plataforma	1290x768mm
Dimensões da plataforma alargada	1400x768mm
Tempo de elevação (sem carga)	24s
Tempo de descida (sem carga)	140s
Incluindo o suporte	No
Peso	418,00Kg
Dimensões (CxLxA)	1840x770x650mm

DISTÂNCIA DE SEGURANÇA

REF.	DESCRIÇÃO					€
53940	POSTE DE PLÁSTICO PARA CORRENTE - AMARELO / PRETO	0.55	-	6	90	15,50€
54326	CORRENTE DE PVC - 7M - AMARELO/PRETO	0.30	-	20	600	8,50€
53987	FITA DE SINAL AMARELO/PRETO - 200M	0.59	-	40	560	10,00€
53942	ELO DE FECHAR PRETO	0.01	50	5000	75000	0,50€
54322	CONJUNTO DE 2 SINAIS DE AVISO DE ALTA TENSÃO	0.05	25	100	-	21,00€



CARROS DE FERRAMENTAS COM 7 GAVETAS

ESPECIAL VEÍCULOS ELÉCTRICOS

REF.	GAVETAS	COR	EQUIPADO	PEÇAS	MATERIAL					€
54236	7	●	Com ferramentas	23	Aço	67.70	-	1	4	1.856,00€
54234	7	●	Com ferramentas	23	Aço	67.70	-	1	4	1.856,00€
54235	7	●	Com ferramentas	23	Aço	67.70	-	1	4	1.856,00€
54233	7	●	Com ferramentas	23	Aço	67.70	-	1	4	1.856,00€

CONTÉM

REF.					€
52162	A	1	0.17	6 72 576	38,00€
53940	B	4	0.55	- 6 90	15,50€
54326	C	4	0.30	- 20 600	8,50€
53942	D	8	0.01	50 5000 75000	0,50€
54093	E	1	2.88	- 4 64	441,00€
54114	F	1	1.48	- 10 100	248,00€
54129	G	1	2.10	- 1 200	110,00€
54130	H	1	0.35	- 21 220	65,00€
54132	I	1	0.70	- 1 39	190,00€
54241	J	1	1.10	- 1 50	120,00€
54322	K	1	0.05	25 100 -	21,00€



ACESSÓRIOS DE OFICINA

392 ENROLADOR DE MANGUEIRA

394 ESCADAS

395 PLATAFORMAS

396 CARRINHOS DE MÃO

398 DIFERENCIAIS



CARRETEL DE CABO ELÉCTRICO

REF.		m	V	W	IP					€
53586		21m	230V	1500 - 3000W	IP44	8.35	-	2	36	168,00€
53585		21m	230V	1500 - 3000W	IP44	8.35	-	2	36	168,00€
53584		12m	230V	1500 - 3000W	IP44	5.10	-	4	48	119,00€
53526		12m	230V	1500 - 3000W	IP44	5.15	-	4	48	119,00€



BLOCO DE CABO



PROTEÇÃO DE SOBRECARGA



COM REPARTIDOR



COM SUPORTE DE PAREDE

CARRETEL DE MANGUEIRA DE AR

REF.		m	"	Pressão do trabalho	Pressão de ruptura						€
53582		22m	3/8"	10BAR/150PSI	30BAR/450PSI	9.5mm	10.40	-	1	14	174,00€
53583		22m	3/8"	10BAR/150PSI	30BAR/450PSI	9.5mm	10.75	-	1	14	174,00€
53532		13m	3/8"	10BAR/150PSI	30BAR/450PSI	9.5mm	6.60	-	2	30	119,00€
53581		13m	3/8"	10BAR/150PSI	30BAR/450PSI	9.5mm	6.70	-	2	36	119,00€
53881		11,5m	1/4"	10BAR/150PSI	30BAR/450PSI	8mm	4.50	-	4	48	79,00€
53882		11,5m	1/4"	10BAR/150PSI	30BAR/450PSI	8mm	4.50	-	4	48	79,00€



COM REPARTIDOR



COM ALÇA



COM ACOPLAMENTO



53582 - 53583

53532-53581-53881-53882

COM SUPORTE DE PAREDE



53872

118,00€

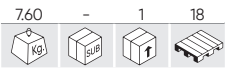

CARRETEL DE MANGUEIRA DE ÁGUA - 15+1,5M

Comprimento do tubo	15+1,5M
Pressão do trabalho	8BAR
Conectores	3/4"
Diâmetro	15,8mm
Material	PVC
Peso	7,50Kg
Dimensões (CxLxA)	440x230x410mm



REPOSIÇÕES DISPONÍVEIS

50797

490,00€

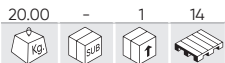

CARRETEL DE MANGUEIRA PARA ÓLEO 15+1 M, 1/2"

Comprimento do tubo	15+1m
Pressão do trabalho	180BAR
Pressão de ruptura	540BAR
Conectores	1/2" BSPT
Diâmetro	12,7mm
Material	Acero/Steel
Peso	19,00Kg
Dimensões (CxLxA)	640x255x630mm



51033

89,00€

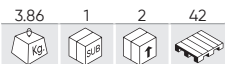

EXTENÇÃO MANUAL DE CABO ELÉCTRICO 25M

Tensão	300V
Potência	1.110-3.200W
Comprimento do cabo	25m
Proteção IP	IP20
Cabo	HO5W-F 3X1,5 mm2 (PVC)
Peso	3,86Kg
Dimensões (CxLxA)	320x230x155mm



EXTENÇÃO DE CORRENTE ELÉTRICA

REF.	m					€
53166	3m	0.45	5	30	600	11,30€
53167	5m	0.65	5	20	600	13,90€
53168	10m	1.20	-	10	300	31,00€



ESCADA TELESCÓPICA

CUMPRE COM: EN 131

REF.	DESCRIÇÃO	Max.	Min.					€
51982	ESCADA TELESCÓPICA 6 DEGRAUS 2M	2000mm	730mm	5.51	-	1	34	120,00€
51983	ESCADA TELESCÓPICA 10 PASOS 3.2M	3200mm	930mm	9.41	-	1	34	185,00€
51984	ESCADA TELESCÓPICA 12 PASOS	3800mm	1020mm	9.78	-	1	21	190,00€

51982



REPOSIÇÕES DISPONÍVEIS



51983



REPOSIÇÕES DISPONÍVEIS



51984



REPOSIÇÕES DISPONÍVEIS



52149

230,00€

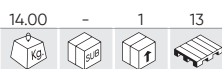

ESCADA TELESCÓPICA EM "V" DOBRÁVEL



Capacidade	150Kg
Altura mínima	835mm
Altura máxima	3800mm
Conformidade com a diretiva europeia	EN131
Material	Al, PT
Peso	14,00Kg
Dimensões (CxLxA)	160x490x835mm

54176

188,00€

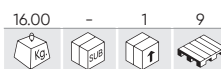

ESCADA MULTIFUNÇÕES



REPOSIÇÕES DISPONÍVEIS



Capacidade	150Kg
Altura mínima	1030mm
Altura máxima	3700mm
Conformidade com a diretiva europeia	EN131
Material	Al
Peso	16,00Kg
Dimensões (CxLxA)	1235x640x1850mm

54681

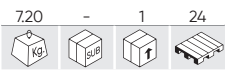

ESCADA DE 3 DEGRAUS

Capacidade	150Kg
Medidas das bandejas	380x26mm
Distância entre tabuleiros	240mm
Conformidade com a diretiva europeia	EN14183: 2003
Peso	6,00Kg
Altura	720mm
Dimensões (CxLxA)	475x650x1150mm
Dimensões da plataforma alargada	475x650x1250mm



74,50€

50517

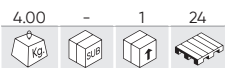

ESCADOTE DE ALUMÍNIO DE 4 DEGRAUS

Capacidade	150Kg
Altura máxima	1300mm
Material	Al
Conformidade com a diretiva europeia	EN131
Peso	4,00Kg
Dimensões (CxLxA)	110x420x1300mm



129,00€

50518



ESCADOTE DE ALUMÍNIO DE 6 DEGRAUS

Capacidade	150Kg
Altura máxima	1910mm
Material	Al
Conformidade com a diretiva europeia	EN131
Peso	5,32Kg
Dimensões (CxLxA)	120x480x1910mm



169,00€

52230

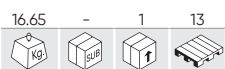

PLATAFORMA DE ALUMÍNIO TELESCÓPICA



REPOSIÇÕES DISPONÍVEIS

Capacidade	150Kg
Dimensões dobradas	300x1090x900mm
Comprimento mínimo	1090mm
Comprimento máximo	1750mm
Altura mínima	550mm

Altura máxima	930mm
Material	Al
Conformidade com a diretiva europeia	EN131
Peso	16,65Kg
Dimensões (CxLxA)	300x1750x900mm

398,00€

50913

229,00€

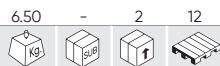

PLATAFORMA DE ALUMÍNIO GRANDE

Capacidade	100Kg
Material	Al
Conformidade com a diretiva europeia	EN131
Dimensões (CxLxA)	1400x300x800mm
Peso	6,50Kg
Dimensões dobradas	1400x300x14mm



50656

290,00€

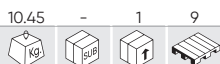

JOGO 2 PLATAFORMAS DE ALUMÍNIO

Capacidade	100Kg
Dimensões da plataforma grande (CxLxA)	1300x300x550mm
Dimensões da plataforma grande dobrada (CxLxA)	1300x300x140mm
Dimensões da plataforma pequena (CxLxA)	1000x300x300mm
Dimensões da plataforma pequena dobrada (CxLxA)	1000x300x140mm
Material	Al
Contém	11897, 15552
Conformidade com a diretiva europeia	EN131
Peso	10,45Kg



REPOSIÇÕES DISPONÍVEIS

52202

95,00€

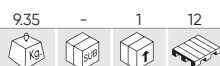

CARRINHO DE MÃO 2 RODAS BASICO DE AÇO CAP.200KG



REPOSIÇÕES DISPONÍVEIS

Capacidade	200Kg
Material	S
Peso	9,35Kg
Dimensões (CxLxA)	500x450x1100mm

50924

342,00€



CARRO PORTA BIDÕES 200KG



Capacidade	200Kg
Material	Fe
Peso	31,00Kg
Dimensões (CxLxA)	990x790x830mm

54308

95,00€

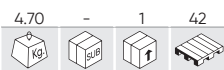

CARRINHO DE MÃO DOBRÁVEL ALUMINIO 90KG

Capacidade	90Kg
Material	Al
Peso	4,70Kg
Dimensões (CxLxA)	440x485x1150mm
Dimensões dobradas	485x70x785mm



54310

59,00€

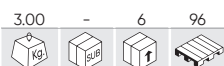

CARRINHO DE MÃO DOBRÁVEL ALUMINIO 75KG

Capacidade	75Kg
Material	Al
Peso	3,00Kg
Dimensões (CxLxA)	270x390x1000mm
Dimensões dobradas	55x390x640mm



54306

219,50€



CARRINHO DE MÃO DOBRÁVEL ALUMINIO 250KG

Capacidade	250Kg
Material	Al
Peso	11,00Kg
Dimensões (CxLxA)	610x620x1200mm
Dimensões dobradas	80x590x1000mm



52200

98,00€

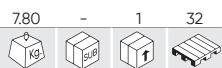

CARRINHO PLATAFORMA DE AÇO 150KG



Capacidade	150Kg
Material	S
Peso	7,80Kg
Dimensões (CxLxA)	735x480x830mm
Dimensões dobradas	735x480x230mm

54305

233,00€



CARRO DOBRÁVEL PLATAFORMA ALUMINIO 300KG



Capacidade	300Kg
Material	Al
Peso	19,00Kg
Dimensões (CxLxA)	900x610x895mm
Dimensões dobradas	900x610x330mm

54262

88,00€

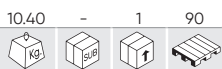

TALHA DE CORRENTE MANUAL DE 1T



Capacidade	1T
Altura de elevação	2,8M
Número de ramais	1
Dimensões da cadeia de carga	6x30x3000mm
Dimensões da cadeia manual	4,5x25x2500mm
Material da cadeia de carga	Acero/Steel 20Mn2
Material da cadeia manual	Acero/Steel Q235
Esforço para carga máxima	304N
Peso	8,50Kg
Dimensões (CxLxA)	250x155x200mm

54263

130,00€



TALHA DE CORRENTE MANUAL DE 2 TONELADA



Capacidade	2T
Altura de elevação	2,8M
Número de ramais	2
Dimensões da cadeia de carga	6x30x3000mm
Dimensões da cadeia manual	4,5x25x2700mm
Material da cadeia de carga	Acero/Steel 20Mn2
Material da cadeia manual	Acero/Steel Q235
Esforço para carga máxima	310N
Peso	12,00Kg
Dimensões (CxLxA)	300x160x195mm

54264

240,00€

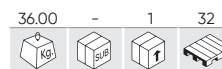

TALHA DE CORRENTE MANUAL DE 5 TONELADA



Capacidade	5T
Altura de elevação	2,8M
Número de ramais	2
Dimensões da cadeia de carga	6x30x3000mm
Dimensões da cadeia manual	4,5x25x2700mm
Material da cadeia de carga	Acero/Steel 20Mn2
Material da cadeia manual	Acero/Steel Q235
Esforço para carga máxima	361N
Peso	33,00Kg
Dimensões (CxLxA)	400x280x200mm



ACESSÓRIOS DO VEÍCULO

400 SINALIZAÇÃO

402 KITS DE EMERGÊNCIA

404 LÂMPADAS

405 TAPETES

406 SEGURANÇA

407 KITS DE PRIMEIROS SOCORROS

408 CONJUNTOS DE FOLE E ABRAÇADEIRAS

409 LIMPADORES DE PARA-BRISAS

410 BICICLETA

411 OUTROS

414 SENSORES DE ESTACIONAMENTO

414 TUBOS FLEXÍVEIS



53778

4,50€

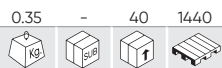

TRIÂNGULO DE SINALIZAÇÃO HOMOLOGADO 27R032736



Peças	1
Material	ABS, PPMA, PVC, PP
Normas	E4 27R-032736
Dimensões dobradas	440x25x45mm
Peso	0,35Kg
Dimensões (CxLxA)	440x405x385mm

52795

5,80€

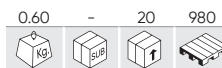

TRIÂNGULO DE SINALIZAÇÃO HOMOLOGADO 27R032738



Peças	1
Material	ABS, PPMA, PVC, PP
Normas	E4 27R-032738
Peso	0,50Kg
Dimensões (CxLxA)	440x405x385mm

KAMIZELKA ODBLASKOWA

CUMPRE COM: EN ISO20471:2023+A1:2016

REF.					€
50654	●	0.13	-	100 2600	4,00€
50966	●	0.12	-	100 2600	4,00€
50966C	●	0.12	-	100 2600	4,00€



50654



50966



50966C

FITA REFLEXIVA DE MARCAÇÃO PARA VEÍCULOS DE MERCADORIAS

CUMPRE COM: CEPE/ONU 104R

REF.					€
51935	●	1.04	-	10 280	139,00€
51936	●	1.04	-	10 480	139,00€
51937	●	1.02	-	10 280	139,00€



53636

22,00€

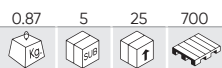

CHAPA DE SINALIZAÇÃO V-20 "CARGA SUPERDIMENSIONADA" - PP



Material	PP
Normas	V20
Peso	0,87Kg
Dimensões (CxLxA)	500x500mm

53507

27,00€

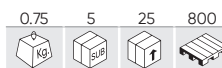

CHAPA DE SINALIZAÇÃO V-20 "CARGA SUPERDIMENSIONADA"



Material	PMMA, Al
Normas	V20
Peso	0,87Kg
Dimensões (CxLxA)	500x500mm

54904 **45,40€**

0.27 20 80 640

NEW

SINALIZADOR DE EMERGÊNCIA GEOLOCALIZÁVEL V16

Luz de emergência para sinalizar qualquer veículo em qualquer tipo de situação de emergência, muito prático e fácil de usar.

- Obligatoriu în Spania începând cu 1 ianuarie 2026.
- Conectat la DGT 3.0. Fără conexiune în afacerea Spaniei.

Brilho	70cd
Proteção IP	IP54
Frequência	0,9 Hz
Temperatura de trabalho	20-50°C
Resistência	180Pa
Temperatura de cor do LED	1700-1800 K
Certificação	V16
Material	ABS/PC
Método de carregamento	Pila/Battery AA (x3)
Magnetizado	Si/Yes
Inclui	GPS ~ x3 Batteries
Visualização	1000M
Peso	0,173Kg
Dimensões (CxLxA)	82x82x49mm

54904N **45,40€**

0.27 20 80 640

NEW

SINALIZADOR DE EMERGÊNCIA GEOLOCALIZÁVEL V16 - PRETO



V16
DGT
GPS

VÍDEO TUTORIAL EM EXPOSITOR DE 20 UDS

18258 **19,50€**

0.25 - 100 1800

NEW

SUPORTE DE VENTOSA PARA SINALIZADOR GEOLOCALIZÁVEL



18259 **5,50€**

0.10 - 100 5600

NEW

EXTENSÃO TELESCÓPICA PARA SUPORTE DE SINALIZADOR GEOLOCALIZÁVEL



18306 **4,70€**

0.05 - 100 1800

NEW

SUPORTE DE VENTOSA PARA BALIZA DE SINALIZAÇÃO DE EMERGÊNCIA V-16



18307 **4,70€**

0.05 - 100 1800

NEW

SUPORTE DE VENTOSA PARA BALIZA DE SINALIZAÇÃO DE EMERGÊNCIA V-16 - ANÔNIMA



54013 **35,00€**

1.15 5 10 250

KIT DE REPARAÇÃO DE PNEUS - COMPRESSOR DE LÍQUIDO DE AR



 REPOSIÇÕES DISPONÍVEIS

Peças	4
Inclui	15317, 15300, 11960, 53150
Peso	1,15Kg
Dimensões (CxLxA)	210x210x70mm

54760 **38,00€**

1.40 - 6 210

KIT DE REPARAÇÃO DE PNEUS - COMPRESSOR DE LÍQUIDO DE AR



 REPOSIÇÕES DISPONÍVEIS

 VÍDEO TUTORIAL

Peças	2
Inclui	17684, 17676
Peso	1,60Kg
Dimensões (CxLxA)	240x165x95mm

KIT EMERGÊNCIA

Ver o preço para as quantidades desenho personalizável, pede cotação. Serigrafia e fotolito não inclui.

54833 4,00€

0.09 - 200 2000

BOLSA PARA KIT DE LUZ DE EMERGÊNCIA E COLETE DE SEGURANÇA – PRETO

NEW

Peças	1
Material	PVC
Cor	Negro/Black
Dimensões (CxLxA)	225x140x110mm

54832 4,00€

0.09 - 200 2000

BOLSA DE PVC PRETA PARA KIT DE EMERGÊNCIA JBM

NEW

Peças	1
Material	PVC
Cor	Negro/Black
Dimensões (CxLxA)	225x140x110mm

54913 3,50€

0.07 - 100 600

ESTOJO PRETO EM EVA PARA KIT DE EMERGÊNCIA

NEW

Peças	1
Material	EVA
Cor	Negro/Black
Dimensões (CxLxA)	240x125x60mm

54835 4,50€

0.04 - 150 1500

ESTOJO DE EVA DE PROTEÇÃO PARA BALIZA DE EMERGÊNCIA

NEW

Peças	1
Material	Espuma EVA / EVA Foam
Cor	Negro/ Black
Dimensões (CxLxA)	100x100x70mm

51694 3,55€

0.14 - 100 1200

BOLSA PRETA PARA KIT DE EMERGÊNCIA COM VIVO

Peças	1
Cor	Negro/Black
Dimensões (CxLxA)	557x90x130mm

51696 3,65€

0.12 - 100 1200

ESTOJO PARA KIT DE EMERGÊNCIA VERMELHA

Peças	1
Cor	Rojo/Red
Dimensões (CxLxA)	550x90x130mm

53621 2,50€

0.05 - 100 3200

BOLSA PLANA PRETA PARA KIT DE EMERGÊNCIA

Peças	1
Cor	Negro/Black
Dimensões (CxLxA)	550x150mm

53623 2,50€

0.05 - 100 3200

BOLSA PLANA CINZA PARA KIT DE EMERGÊNCIA

Peças	1
Cor	Gris/Grey
Dimensões (CxLxA)	550x150mm

KIT EMERGÊNCIA

Ver o preço para as quantidades desenho personalizável, pede cotação.
Serigrafia e fotolito não inclui.

55089 36,00€

0.48 - 65 1300 **NEW**

KIT DE EMERGÊNCIA - ESTOJO EVA E SINALIZADOR GEOLOCALIZÁVEL



54835 54904

55087 42,00€

0.34 - 25 500 **NEW**

KIT DE EMERGÊNCIA - SACO EVA + BALIZA DE SINALIZAÇÃO (V-16) + COLETE DE SEGURANÇA



54913 50966C 54904

54534 52,00€

0.37 - 25 500

KIT DE EMERGÊNCIA - ESTOJO DE PVC, COLETE E SINALIZADOR GEOLOCALIZÁVEL



54832 50966C 54904

55088 42,00€

0.48 - 160 **NEW**

KIT DE EMERGÊNCIA - SACO PVC + BALIZA DE SINALIZAÇÃO (V-16) + COLETE DE SEGURANÇA



54833 50966C 54904

KIT EMERGÊNCIA ESTOJO CON RIBETE

REF.	Color	Quantity	Weight (Kg)	Length (cm)	Width (cm)	Height (cm)	Price (€)
53088	Grey	x1	0.59	-	10	200	11,50€
53089	Black	x1	0.61	-	10	200	11,50€
53090	Red	x1	0.59	-	10	200	11,50€

KIT EMERGÊNCIA ESTOJO MINI

REF.	Color	Quantity	Weight (Kg)	Length (cm)	Width (cm)	Height (cm)	Price (€)
53092	Grey	x1	0.52	-	10	200	10,20€
53093	Black	x1	0.52	-	10	200	10,20€



KIT EMERGÊNCIA

REF.	△						€
52773	●	x2	MK H4	1.01	-	10 200	17,80€
52781	●	x2	MK H4	1.14	-	10 200	17,80€
52774	●	x2	MK H7	0.99	-	10 200	17,80€
52775	●	x2	MK H7+H1	1.01	-	10 200	18,10€
52783	●	x2	MK H7+H1	1.01	-	10 200	18,10€



KIT EMERGÊNCIA ESTOJO BORDA

REF.	△						€
53178	●	x1		0.64	-	10 200	12,20€
53179	●	x1		0.65	-	10 200	12,20€
53180	●	x1		0.63	-	10 200	12,20€
53182	●	x2		0.99	-	10 200	15,80€
53183	●	x2		0.99	-	10 200	15,80€
53184	●	x2		0.98	-	10 200	15,80€



MINI ESTOJO DE LÂMPADA

REF.							€
51615	12V	H9	0.09	10	100	1500	6,50€
50915	12V	H7+H1	0.10	10	100	1800	4,60€
51614	12V	H4	0.10	10	100	1800	3,95€
50431	12V	H7	0.08	10	100	1800	3,80€



51615

50915

50431

51614

50551

350,00€

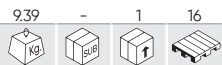

ARMÁRIO DE LÂMPADAS PARA TURISMOS

Lâmpadas Halógenas

x10	H1 55 W P14.5s
x4	H2 55 W X511
x4	H3 55 W PK22s
x10	H4 60/55 W P43t
x10	H7 55 W PX26d
x4	HB3 65 W P20d
x4	HB4 55 W P20d
x4	H9 65 W PGJ19-5
x4	H11 65 W PGJ19-2

Foco Europeu

x20	T5 1,2 W W2.1x4,6d
x12	T10 5 W W2.1x9,6d
x12	T10 3 W W2.1x9,6d
x10	T13 10 W W2.1x9,6d
x10	T15 18 W W2.1x9,6d
x10	T20 21 W W5x16d
x10	T20A 21 W W5x16d Ambar
x10	T20 21/5 W W5x16d

Stop de 1 Polo

x30	P21W 21 W BA15s
x10	P21WA 21 W BA15s Ambar
x10	PY21W 21 W BAU15s Com desc.

Stop de 2 Polos

x40	R21/5 W 21/5 W BAY15d PLAFONIER
x22	C5W 5 W SV8.5 11x38

Lâmpadas Piloto

x30	RSW 5 W BA15s
x30	R10W 10 W BA15s

Lâmpadas indicadoras

x22	T4W 4 W BA9s
-----	--------------



50585

18,50€



TAPETE DE BORRACHA UNIVERSAL - REVERSIBLE



Peças	4
Dimensões frontais	670x460mm
Dimensões traseiras	460x330mm
Material	Goma/Rubber
Compatível com	Multimarca/Multi-brand
Peso	2,86Kg

53241

9,00€

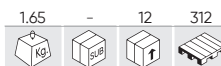

TAPETE DE BORRACHA UNIVERSAL



Peças	4
Dimensões frontais	635x445mm
Dimensões traseiras	330x430mm
Material	Goma/Rubber
Compatível com	Multimarca/Multi-brand
Peso	1,65Kg

52534

18,00€



TAPETE DE TELA UNIVERSAL COM TALONERA BORRACHA



Peças	4
Dimensões frontais	425x660mm
Dimensões traseiras	295x425mm
Material	Moqueta/Carpet, Goma/Rubber
Compatível com	Multimarca/ Multi-brand
Peso	1,55Kg

52535

16,50€



TAPETE DE TELA UNIVERSAL + TALONERA TELA



Peças	4
Dimensões frontais	425x660mm
Dimensões traseiras	295x425mm
Material	Moqueta/Carpet, Goma/Rubber
Compatível com	Multimarca/Multi-brand
Peso	1,55Kg

52530

14,00€



TAPETE DE TELA UNIVERSAL



Peças	4
Dimensões frontais	390mm
Dimensões traseiras	365x480mm
Material	Moqueta/Carpet, Goma/Rubber
Compatível com	Multimarca/Multi-brand
Peso	2,00Kg



52259

3,75€

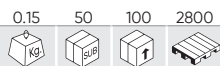

MARTELO DE JANELA DO CARRO COM SUPORTE E CORTADOR DE CINTOS DE SEGURANÇA



Largura	750mm
Altura	130mm
Peso	0,15Kg

51266

30,00€



CINTO DE SEGURANÇA DE 3 PONTOS ENROLÁVEL PARA AUTOCARROS



Material	PL
Normas	E4-16R-0436232
Comprimento	2900mm
Peso	1,13Kg

50644

13,00€



CINTO DE SEGURANÇA DE 2 PONTOS PARA AUTOCARROS



Material	PL
Normas	E8-16R-08/00-12199-00
Comprimento	1250mm
Peso	0,40Kg

50717

23,00€



CINTO DE SEGURANÇA DE 2 PONTOS ENROLÁVEL PARA AUTOCARROS



Material	PL
Normas	E4-16R-0436232
Comprimento	1330mm
Peso	0,75Kg

51412

3,00€

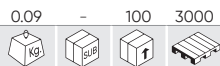

PORTA-PLACA DE MATRICULA ANÔNIMA

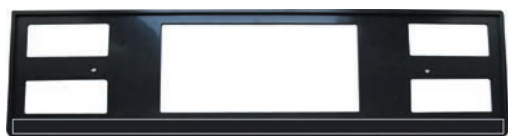

Material	PVC
Dimensões (CxX)	532x137mm
Peso	0,09Kg

51697

0,80€



ESPÁTULA TIRA GELO



Dimensões (CxLxA)	180x85x30mm
Peso	0,03Kg

54042

13,00€

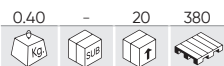

BOLSA DE PRIMEIROS SOCORROS DIN13164:2022

- x1 Fita adesiva DIN13019-A 5x2,5
- x4 Fitas adesivas din 13019-e 10x6
- x2 Adesivos elásticos para os dedos 4x7 cm
- x2 2 Adesivos elásticos para os dedos 12x2 cm
- x2 Tiras de fita adesiva à prova d'água 1,9x7,2 cm
- x4 Tiras de fita adesivas à prova d'água 2,5x7,2 cm
- x1 Bandagem estéril DIN 13151-K 8x8 cm
- x2 Bandagens estéreis DIN 13151-M 8x10 cm
- x1 Bandagem estéril DIN 13151-G 10x12 cm
- x1 Bandagem de primeiros socorros DIN 13152-BR 60x40 cm
- x1 Bandagem de primeiros socorros DIN 13152-A 60x80 cm
- x2 Bandagens estéreis DIN 61634FB6 6 cm x 400 cm
- x3 Bandagens estéreis DIN 61634FB6 8 cm x 400 cm
- x1 Manta de resgate 160x210 cm
- x6 Compressas estéreis para feridas 10x10 cm
- x2 Bandagens triangulares DIN 13168-D
- x1 Tesoura DIN 58279-A145 145 cm
- x4 Luvas descartáveis din en 455-1
- x2 Lenços umedecidos para limpar pele

54042N

13,00€



- x1 Lista de conteúdos
- x1 Guia de primeiros socorros
- x2 Máscaras cirúrgicas DIN EN 14683

51246

8,00€

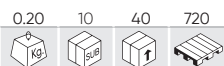

BOLSA DE PRIMEROS SOCORROS

- x1 Folha de primeiros socorros
- x1 Tesoura
- x1 Par de luvas
- x2 Toalhetas de álcool
- x2 Pensos para cortes
- x1 25gr. De algodão



- x1 Pensos para queimaduras
- x1 Liga
- x1 Rolo adesivo

54072

38,50€



MALETA DE PRIMEIROS SOCORROS DIN13157

- x1 Gesso adesivo 5 x 25 - DIN13019-A
- x1 Conjunto de bandagens adesivas 10 x 6 cm (8 unid.) - DIN13019-E
- x6 Remendos de dedo 4 x 6,5 cm
- x6 Remendos de dedo 120 x 20 mm
- x6 Remendos de dedo 7,2 x 1,9 cm
- x12 Remendos de dedo 25 x 72 mm
- x1 Conjunto de bandagens de primeiros socorros 6 x 8 cm - DIN13151-K
- x3 Conjuntos de bandagens de primeiros socorros 8 x 10 cm - DIN13151-M
- x1 Conjunto de ataduras de primeiros socorros 10 x 12 cm - DIN13151-G
- x1 Compressa estéril (curativo de tratamento de queimadura) 60 x 80 cm - DIN13152-A
- x3 Curativos esterilizados (compressas) 100 x 100 mm, 2 unidades / bolsa - DIN58953-2
- x2 Tapa-olhos - 55 mm x 75 mm 1,5 g
- x1 Compressa fria para tratamento de emergência, min. 200 Cm2
- x1 Manta de primeiros socorros, 160 x 210 cm, 12 microns
- x2 Bandagens elásticas (gaze), 6 cm por 400 cm - DIN61634 FB6
- x2 2 Bandagens elásticas (gaze), 8 cm por 400 cm - DIN61634 FB8
- x2 Bandagens triangulares 96x96x136 cm - DIN13168-D
- x1 Tesoura de metal 190 mm - DIN58279-B190
- x2 Sacos de plástico para lixo, 300 x 400 mm, 45 microns
- x5 Materiais não tecidos 20 x 30 cm, min. 15 G/h9m2
- x1 Luvas descartáveis de pvc l-aq11.5 (Conjunto de 4) - DIN EN 455-1



- x1 Livreto de informações
- x2 Máscaras cirúrgicas DIN EN 14683
- x4 Toalhetes de limpeza de pele saudáveis

52644

0.19	-	20	400

KIT DE FOLE DE TRANSMISSÕES UNIVERSAL

REF.							€
11922	A	1PCS	0.10	-	80	1260	5,70€
13880	B	1PCS	0.01	-	600	21000	0,47€
52633	C	1PCS	0.02	100	800	6400	1,00€



8,80€

53693

19.80	-	1	16

KIT DE 100 FOLE DE TRANSMISSÕES

REF.							€
52633	A	100PCS	0.02	100	800	6400	1,00€
13738	B	100PCS	0.08	-	150	1800	3,50€
13879	C	100PCS	0.09	-	150	5250	2,40€



521,00€

53698

19.80	-	1	24

KIT DE 100 FOLE DE TRANSMISSÃO PARA FURGONETA

REF.							€
52633	A	100PCS	0.02	100	800	6400	1,00€
13739	B	100PCS	0.13	-	100	1600	5,50€
13880	C	100PCS	0.01	-	600	21000	0,47€



717,00€

53695

11.25	-	1	24

KIT DE 80 FOLE DE TRANSMISSÃO UNIVERSAL

REF.							€
52633	A	80PCS	0.02	100	800	6400	1,00€
11922	B	1PCS	0.10	-	80	1260	5,70€
13880	C	80PCS	0.01	-	600	21000	0,47€



504,00€

SERIE124

22.15	-	-	20

SÉRIE PROMOCIONAL ESPECIAL KIT FOLE

REF.							€
51861	A	1PCS	4.00	-	2	32	199,00€
52633	B	100PCS	0.02	100	800	6400	1,00€
13738	C	100PCS	0.08	-	150	1800	3,50€
13879	D	100PCS	0.09	-	150	5250	2,40€



710,00€

KIT DE FOLE DE TRANSMISSÕES

REF.							€
51703	PARA CARRINHAS		0.28	-	20	400	10,50€
51705	PARA TURISMO		0.23	-	20	400	8,45€



51861

199,00€

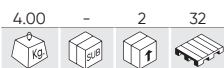

MÁQUINA PNEUMÁTICA P/MONTAR FOLES DE TRANSMISSÕES



Entrada de ar	1/4"
Pressão do trabalho	9BAR
Material	Alumínio/Aluminum
Abertura	20-100mm
Peso	4,00Kg
Dimensões (CxLxA)	200x200x450mm

52829

19,00€

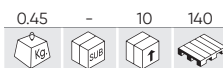

FERRAMENTA P/MONTAR FOLES DE TRANSMISSÕES



Diâmetro exterior	100mm
Diâmetro interior	95mm
Peso	0,45Kg
Comprimento	410mm

ABRAÇADEIRAS

REF.	mm					€
11890	50-125mm	0.01	100	1000	8000	0,55€
11891	15-45mm	0.004	100	2000	48000	0,50€
52633	15-45mm / 50-125mm	0.02	100	800	6400	1,00€



LIMPADOR DE PARA-BRISA

REF.	"	mm					€
53745	11"	280mm	0.20	10	50	800	6,80€
53746	12"	310mm	0.20	10	50	800	6,90€
53747	13"	330mm	0.20	10	50	900	6,90€
53748	14"	350mm	0.20	10	50	800	7,00€
53749	15"	380mm	0.20	10	50	900	7,00€
53750	16"	410mm	0.20	10	50	900	7,10€
53751	17"	430mm	0.20	10	50	900	7,20€
53752	18"	460mm	0.25	10	50	800	7,60€
53753	19"	480mm	0.25	10	50	800	7,90€
53754	20"	510mm	0.25	10	50	900	8,00€
53755	21"	530mm	0.25	10	50	700	8,00€
53756	22"	560mm	0.25	10	50	600	8,20€
53757	24"	610mm	0.25	10	50	600	8,70€
53758	26"	650mm	0.30	10	50	350	9,00€
53759	28"	700mm	0.30	10	50	550	9,20€
53760	30"	750mm	0.30	10	50	500	10,30€

11 ADAPTADORES DIFERENTES: PARA VÁRIOS APLICATIVOS



JBMWBEXP

26,00€

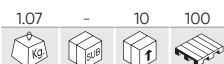

EXPOSITOR ESCOVAS DE LIMPA VIDROS OBN



53919

81,00€

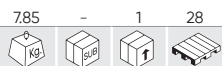

SUPOORTE DE REPARO DE BICICLETAS



Material	S, ABS, NY
Capacidade	30Kg
Altura máxima	1880mm
Altura mínima	1070mm
Peso	7,85Kg

54166

33,00€



BOMBA DE PÉ PARA PNEUS DE BICICLETA



Material	Al
Pressão do trabalho	160PSI
Compatível com	Válvulas/Valves Schrader, Presta, Dunlop
Medidas	32x530mm
Peso	0,90Kg

54170

17,70€

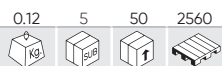

BOMBA DE MÃO PORTÁTIL PARA BICICLETA



Material	Al
Pressão do trabalho	100PSI
Compatível com	Válvulas/Valves Presta, Schrader
Medidas	21x195mm
Peso	0,12Kg

54074

19,70€

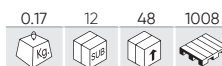

FERRAMENTA MULTIFUNCCIONAL DE REPARO DE BICICLETAS



x1	Ponta cruzada	x1	Pino de desmontagem
x7	Soquetes hex	x1	Chave inglesa
x1	Chave de fenda	x1	Chave de roda dentada T25
x1	Ferramenta de montagem de cadeia	x1	Gancho de cadeia
x2	Alavancas para pneus		

54073

70,00€



CONJUNTO DE FERRAMENTAS PARA BICICLETA - 20 PÇS



Peças	20
Dimensões (CxLxA)	220x220x70mm
Peso	2,00Kg

54169

15,20€

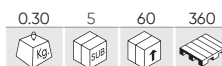

CADEADO DE COMBINAÇÃO PARA BICICLETA



Material	S, ABS, PVC
Medidas	10x1000mm
Peso	0,30Kg

53561

28,00€

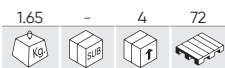

CALÇO DE RODA



REPOSIÇÕES
DISPONÍVEIS



Peças	1
Material	S, PP
Capacidade	30T
Peso	1,66Kg
Dimensões (CxLxA)	470x200x300mm

53508

14,00€



CALÇOS DE RODA



Peças	2
Material	S, PP
Capacidade	1T
Peso	0,35Kg
Dimensões (CxLxA)	220x90x90mm

51858

15,00€

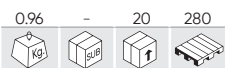

PÁ DOBRÁVEL



Material	ME
Altura máxima	600mm
Altura mínima	240mm
Peso	0,96Kg

53033

22,00€



PÁ COM CABO EXTENSÍVEL



Material	Al
Altura máxima	119mm
Altura mínima	85mm
Peso	0,63Kg

53964

11,00€

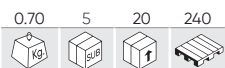

CORDA MULTIUSOS 30M 1/4"



Material	PP
Medida	30m
Diâmetro	1/4"
Carga máxima	550Kg
Peso	0,70Kg

53965

29,00€

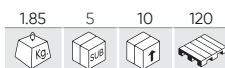

CORDA MULTIUSOS 30M 1/2"



Material	PP
Medida	30m
Diâmetro	1/2"
Carga máxima	1200Kg
Peso	1,85Kg

KIT SUPORTE + MATERIAL DE CUIDADO DO VEÍCULO

50400

198,00€

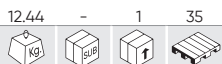

- 53705 SUPORTE DE PAREDE
- 51978 ROLO COBRE ASSENTOS
- 52057 ROLO DE FILM PARA VOLANTE
- 52058 CABO PARA ROLO DE FILM
- 50409 TAPETE ANÔNIMO EM PAPEL

50403

119,00€



- 52065 SUPORTE DE PAREDE
- 51978 ROLO COBRE ASSENTOS
- 52057 ROLO DE FILM PARA VOLANTE
- 52058 CABO PARA ROLO DE FILM

50410

189,00€



- 53705 SUPORTE DE PAREDE
- 52244 ROLO COBRE ASSENTOS
- 52057 ROLO DE FILM PARA VOLANTE
- 52058 CABO PARA ROLO DE FILM
- 50409 TAPETE ANÔNIMO EM PAPEL

53705

98,00€



SUPORTE DE PAREDE PARA ROLO COBREASSENTOS, ROLO VOLANTE E TAPETES DE PAPEL



Cor Verde/Green, Negro/Black
 Peso 4,90Kg
 Dimensões (CxLxA) 730x200x500mm

52065

45,00€

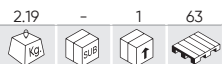

SUPORTE DE PAREDE DE ROLO COBRE-ASSENTO



Cor Verde/Green, Negro/Black
 Comprimento 735mm
 Peso 2,19Kg
 Dimensões (CxLxA) 790x155x115mm

50916

0,99€

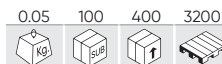

KIT MANUTENÇÃO DE LIMPEZA EM BOLSA INDV.



52057 8,00€

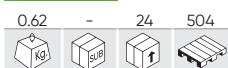

ROLO DE FILM PARA VOLANTE

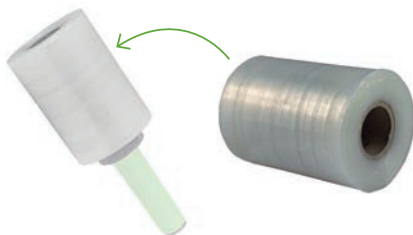

Diâmetro	90mm
Comprimento	180m
Compatível com	52058
Espessura	23MIL
Peso	0,62Kg
Dimensões (CxLxA)	128x90x90mm

52058 4,80€



CABO PARA ROLO DE FILM COM REF.52057



Diâmetro	30mm
Comprimento	195mm
Compatível com	52057
Peso	0,06Kg
Dimensões (CxLxA)	195x55x35mm

51978 89,00€



ROLO COBRE ASSENTOS 25MC 250UDS



Peças	250
Material	25mc
Peso	9,70Kg

52244 89,00€



ROLO COBRE ASSENTOS DESENHO ANÔNIMO 25MC 250UDS



Peças	250
Material	25mc
Peso	9,55Kg

50409 26,00€

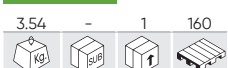

TAPETE ANÔNIMO EM PAPEL



Peças	250
Material	Papel/Paper
Peso	3,54Kg
Dimensões (CxLxA)	457x430x25mm

51824 45,00€

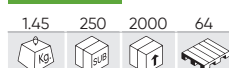

PROTECTOR DE VOLANTE PLÁSTICO - 250UDS



Peças	250
Material	Plástico/Plastic
Espessura	18µm
Peso	1,45Kg
Dimensões (CxLxA)	320x320x165mm

53226

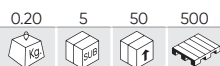

CAPA PARA ASSENTO DE CARRO

Marcas	Universal
Material	Nylon
Peso	0,20Kg
Dimensões (CxLxA)	345x270x5mm

15,00€



51863

64,00€

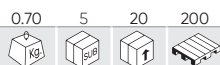

SENSOR DE ESTACIONAMENTO COM MEDIDOR DE APROXIMAÇÃO VISUAL E ACÚSTICO

Tensão nominal	12V
Potência	3,6W
Temperatura de trabalho	-20°C/+70°C
Distância de detecção	0,3-2,0m
Ângulo de detecção	H-60°, V-60°
Quantidade de sensores	4
Indicadores	1
Peso	0,70Kg



51973

53,00€

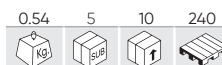

SENSOR DE ESTACIONAMENTO COM MEDIDOR DE DISTÂNCIA ACÚSTICO

Tensão nominal	12V
Potência	3,6W
Temperatura de trabalho	-20°C/+70°C
Distância de detecção	0,3-2,0m
Ângulo de detecção	H-60°, V-60°
Quantidade de sensores	4
Indicadores	0
Peso	0,54Kg



TUBOS FLEXÍVEL INNERBRAID

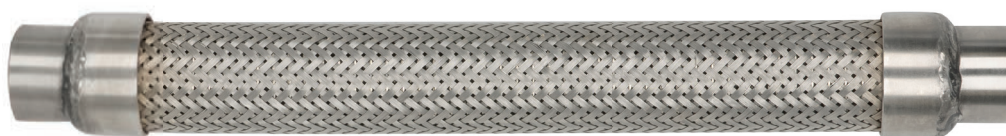

REF.	DESCRIÇÃO	KG	M³	CM	QTD	€
51706	Ø 25mmL x 300mmL	0.35	-	25	1500	22,80€
51707	Ø 45mmL x 100mmL	0.27	-	25	1200	9,05€
51708	Ø 45mmL x 150mmL	0.38	-	25	900	14,20€
51709	Ø 45mmL x 200mmL	0.50	-	25	750	14,70€
51710	Ø 45mmL x 250mmL	0.65	-	25	600	17,80€
51711	Ø 45mmL x 300mmL	0.71	-	25	450	21,20€
51712	Ø 50mmL x 100mmL	0.30	-	25	-	8,65€
51713	Ø 50mmL x 150mmL	0.45	-	25	-	13,10€
51714	Ø 50mmL x 200mmL	0.56	-	25	750	15,80€
51715	Ø 50mmL x 250mmL	0.70	-	25	600	20,30€
51716	Ø 50mmL x 300mmL	0.83	-	25	450	23,60€

REF.	DESCRIÇÃO	KG	M³	CM	QTD	€
51717	Ø 55mmL x 100mmL	0.35	-	25	-	11,20€
51718	Ø 55mmL x 150mmL	0.50	-	25	-	14,80€
51719	Ø 55mmL x 200mmL	0.65	-	25	400	22,00€
51720	Ø 55mmL x 250mmL	0.85	-	25	350	23,50€
51721	Ø 55mmL x 300mmL	1.00	-	25	375	25,00€
51722	Ø 60mmL x 100mmL	0.36	-	25	750	13,10€
51723	Ø 60mmL x 150mmL	0.50	-	25	450	18,70€
51724	Ø 60mmL x 200mmL	0.66	-	25	400	24,40€
51725	Ø 60mmL x 250mmL	0.83	-	25	350	28,30€
51726	Ø 60mmL x 300mmL	0.96	-	25	250	31,40€
51727	Ø 60mmL x 400mmL	1.62	-	25	200	49,00€

DISPONÍVEL EM CAIXA INDIVIDUAL

ACESSÓRIOS DE PNEUS

416 CONTRAPESOS

418 REPARAÇÃO DE FUROS

419 VÁLVULAS DE PNEUS

419 REMOÇÃO E INSTALAÇÃO



51908

44,00€

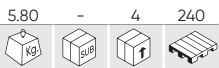

**DISPENSADOR DE CONTRAPESOS AUTO-
ADESIVOS PASTILHAS DE FERRO 5GR**



Peças	1000
Material	Hierro/Iron
Gramas	5
Peso	5,80Kg
Dimensões (CxLxA)	35x295x295mm

53256

34,00€



**DISPENSADOR DE CONTRAPESOS AUTO-
ADESIVOS PASTILHAS DE FERRO 5G X 1.000**



Peças	1000
Material	Hierro/Iron
Gramas	5
Peso	5,30Kg
Dimensões (CxLxA)	40x295x295mm



NEW CONTRAPESO DE CLIP ADESIVA FERRO

REF.	DESCRIÇÃO					€
54844	x100 60GR. (12X5G)	6.00	-	4	240	39,00€
54655	x100 60GR (4X10G 4X5G)	6.00	-	4	200	39,00€
54885	x100 45GR. (3X5G + 3X10G)	4.50	-	4	240	23,00€



54844



54885



54655



54787



54788



54884

NEW CONTRAPESO DE CLIP ADESIVA FERRO - PRETO

REF.	DESCRIÇÃO					€
54787	x100 60GR (12X5G)	5.95	100	4	200	37,00€
54788	x100 60G (4X10G + 4X5G)	6.05	100	4	200	37,00€

NEW CONTRAPESO DE CLIP ADESIVA ZINCO

REF.	DESCRIÇÃO					€
54884	x100 60GR (12X5G)	4.80	-	4	360	98,00€

53864

138,00€

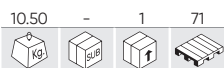

CAIXA DE CONTRAPESOS SURTIDO

CONTRAPESOS DE ZINC COM GRAPA

PARA JANTE UNIVERSAL			PARA JANTE ALUMÍNIO		
54656	20 PCS	5g	54666	20 PCS	5g
54657	20 PCS	10g	54667	20 PCS	10g
54658	20 PCS	15g	54668	20 PCS	15g
54659	20 PCS	20g	54669	20 PCS	20g
54660	20 PCS	25g	54670	20 PCS	25g
54661	10 PCS	30g	54671	10 PCS	30g
54662	10 PCS	35g	54673	10 PCS	35g
54663	10 PCS	40g	54674	10 PCS	40g

CONTRAPESOS DE CLIP ADESIVAS EM PASTILHAS

52666	70 PCS	60g: 4x10g / 4x5g
-------	--------	-------------------



CONTRAPESO COM GRAPA DE ZINC

JANTE UNIVERSAL

REF.	g						€/△
54656	5g	100	0.50	-	16	1024	10,50€
54657	10g	100	1.00	-	16	1024	21,00€
54658	15g	100	1.50	-	8	768	31,50€
54659	20g	100	2.00	-	8	640	42,00€
54660	25g	100	2.50	-	8	480	52,50€
54661	30g	100	3.00	-	6	504	63,00€
54662	35g	100	3.50	-	4	320	73,50€
54663	40g	100	4.00	-	4	256	84,00€
54664	45g	100	4.50	-	4	320	94,50€
54665	50g	100	5.05	-	4	256	97,00€

APRESENTAÇÃO EM SACOS DE 100 UNIDADES.

ESPECIAL PARA JANTE ALUMÍNIO

REF.	g						€/△
54666	5g	100	0.50	-	16	800	10,50€
54667	10g	100	1.00	-	8	768	21,00€
54668	15g	100	1.50	-	12	600	31,50€
54669	20g	100	2.00	-	8	550	42,00€
54670	25g	100	2.50	-	6	480	52,50€
54671	30g	100	2.96	-	6	300	63,00€
54673	35g	100	3.50	-	4	320	73,50€
54674	40g	100	4.00	1	4	320	84,00€
54675	45g	100	4.50	-	4	320	94,50€
54676	50g	100	5.05	-	4	256	97,00€

APRESENTAÇÃO EM SACOS DE 100 UNIDADES.



51355

19,00€

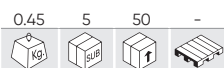

ALICATES DE EQUILÍBRIO DE PESO

Peças	1
Material	CSTL
Comprimento	240mm
Abertura	32mm
Peso	0,45Kg
Dimensões (CxLxA)	320x120x30mm



54013

35,00€

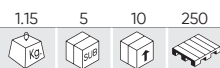

KIT DE REPARAÇÃO DE PNEUS -
COMPRESSOR DE LÍQUIDO DE AR



REPOSIÇÕES
DISPONÍVEIS



Peças	4
Inclui	15317, 15300, 11960, 53150
Peso	1,15Kg
Dimensões (CxLxA)	210x210x70mm

54760

38,00€



KIT DE REPARAÇÃO DE PNEUS -
COMPRESSOR DE LÍQUIDO DE AR



REPOSIÇÕES
DISPONÍVEIS



VÍDEO
TUTORIAL



Peças	2
Inclui	17684, 17676
Peso	1,60Kg
Dimensões (CxLxA)	240x165x95mm

52652

2,80€



CHAVE MULTIFUNCCIONAL
PARA OBUSES



Peças	1
Material	Acero, Steel
Peso	0,03Kg
Dimensões (CxLxA)	115x65x10mm

52653

3,00€



FERRAMENTA PARA OBUSES



Peso	0,03Kg
Dimensões (CxLxA)	172x50x15mm

51814

8,00€



SPRAY TAPA FUROS
300ML



Cor	Blanco/White
Capacidade	300mL
Contém	CAS 74-98-6, CAS 107-21-1, CAS 308062-28-4
Níveis	pH10
Peso	0,30Kg
Dimensões (CxLxA)	225x65x50mm

52662

39,00€



KIT DE REPARAÇÃO DE PNEUS



REPOSIÇÕES
DISPONÍVEIS



Peças	19
Inclui	12973, 13805, 13806
Peso	0,63Kg
Dimensões (CxLxA)	200x145x45mm

52663

30,00€



KIT DE REPARAÇÃO DE PNEUS



REPOSIÇÕES
DISPONÍVEIS



Peças	25
Inclui	12973, 13805, 13806
Peso	1,20Kg
Dimensões (CxLxA)	280x180x60mm

52673 18,00€

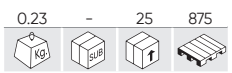

JOGO DE TAMPÃO E OBUSES PARA PNEUS



REPOSIÇÕES DISPONÍVEIS



Peças	217
Material	Al, PT
Inclui	11903, 11904, 11905, 11906, 11907, 11960
Peso	0,23Kg
Dimensões (CxLxA)	226x115x50mm

53150 24,00€

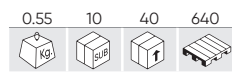

COMPRESSOR DE AR



Tensão de funcionamento	DC12V
Corrente máxima	10A
Potência	100W
Pressão de ar máxima	10BAR
Fluxo de ar	16L/min
Comprimento do cabo	2,8m
Peso	0,55Kg
Dimensões (CxLxA)	55x165x120mm

52643 599,00€

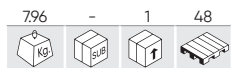

RISCADOR DE PNEUS

Tensão	220V
Potência	350W
Frequência	50-60Hz
Peso	7,96Kg
Dimensões (CxLxA)	200x130x190mm



REPOSIÇÕES DISPONÍVEIS



VÁLVULAS PARA PNEUS

REF.	DESCRIÇÃO					€
51741	TR413 45mm	0.01	100	1000	48000	0,50€
51742	TR414 51mm	0.01	100	1000	60000	0,50€
51743	TR418 64mm	0.02	100	1000	48000	0,58€



51741



51742



51743

FERRAMENTA DESMONTADORA DE PNEUS

REF.					€
52657	0.18	5	20	800	40,50€
52658	0.17	-	20	800	43,00€
52659	0.26	-	20	1920	40,50€
54329	0.20	10	100	600	45,00€



52657

52658

52659

54329

54825

0.55 5 20 320

NEW

KIT PARA LIMPEZA E RECONDICIONAMENTO DE ALOJAMENTOS DE VÁLVULAS PARA JANTES

Peças	6
Conexão rápida	3/8"
Peso	0,55Kg
Dimensões (CxLxA)	205x130x57mm



30,50€

52649

5,00€

0.32 10 50 2250

FERRAMENTA DE METAL PARA INSTALAR VÁLVULAS DE PNEUS



Material	Metal
Peso	0,32Kg
Dimensões (CxLxA)	405x150x10mm

52650

5,00€

0.15 10 100 2400

FERRAMENTA DE PLÁSTICO PARA INSTALAR VÁLVULAS DE PNEUS



Material	Plástico/Plastic
Peso	0,15Kg
Dimensões (CxLxA)	370x95x30mm

52655

40,50€

0.39 - 25 1500

AVALANCA PLÁSTICA DE REMOVER PNEUS



Material	Plástico/Plastic
Peso	0,39Kg
Dimensões (CxLxA)	170x80x60mm

52656

39,50€

0.40 5 20 1920

AVALANCA PLÁSTICA DE REMOVER PNEUS



Material	Plástico/Plastic
Peso	0,40Kg
Dimensões (CxLxA)	180x170x60mm

51416

15,00€

1.05 10 20 320

CHAVE TELESCÓPICA PARA RODAS COM SOQUETES REVERSÍVEIS 330-490MM



330-490mm	
17-19, 21-23mm	

54911

34,00€

1.40 - 10 490

NEW

CHAVE DINAMOMÉTRICA DE 120 NM COM CHAVES DE CAIXA REVERSÍVEIS PARA RODAS



VIDEO TUTORIAL



420mm	
17-19, 21-23mm	

CHAVE DE RODA JUNTA SOLDADA

REF.	"			mm						€
51661	1/2"		355mm	17, 19, 21mm	1.17	5	20	440		15,00€
52881	1/2"		400mm	17, 19, 21, 22mm	1.40	-	10	300		19,00€
52880	3/4"		700mm	24, 27, 32mm	3.75	-	5	90		45,00€



51661



52881



52880

51362

3,00€

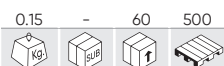

AVALANCA PARA PNEUMÁTICOS 12" (30,48CM)



Comprimento	12"-305mm
Material	Acero de carbono/Carbon steel
Peso	0,15Kg
Dimensões (CxLxA)	305x26x10mm

51358

7,50€

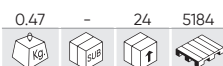

AVALANCA PARA PNEUMÁTICOS 16" (40,64CM)



Comprimento	16"-406mm
Material	Acero de carbono/Carbon steel
Peso	0,47Kg
Dimensões (CxLxA)	406x26x10mm

51359

9,00€







AVALANCA PARA PNEUMÁTICOS 24" (60,96CM)



Comprimento	24"-609,6mm
Material	Acero de carbono/Carbon steel
Peso	0,90Kg
Dimensões (CxLxA)	609,6x26x10mm

CASQUILHO CENTRADOR PARA RODAS DE PESADOS

REF.	mm					€
52645	25x22x2,5mm	0.01	50	1000	38000	0,50€
52646	25x12x2,0mm	0.00	50	1000	80000	0,50€
53037	23x12x2,5mm	0.01	50	1000	35000	0,50€
53038	21x12x2,5mm	0.01	50	1000	35000	0,50€
53039	25x19x2,5mm	0.02	50	1000	35000	0,50€



52645



52646



53037



53038



53039

52552

138,00€



CALÇADORA DE PNEUS PORTÁTIL

Capacidade	18L
Pressão do trabalho	6-8BAR
Pressão máxima	10BAR
Normas	2014/68/EU, 2014/29/EU
Material	S
Temperatura de trabalho	-20/40°C
Peso	12,00Kg
Dimensões (CxLxA)	430x360x300m



REPOSIÇÕES DISPONÍVEIS



NEW DESMONTADORA DE PNEUS COM TORRE BASCULANTE AUTOMÁTICA



VIDEO TUTORIAL

54965

3.549,00€

233,00	-	1	1

Alimentação	220V
Potência	0,75Kw
Pressão do trabalho	8-10BAR
Torque máx.	1078Nm
Diâmetro máximo da roda	10-24"
Nível de ruído	75dB
Peso	233,00Kg
Dimensões (CxLxA)	880x435x1880mm



REPOSIÇÕES DISPONÍVEIS

55021

3.549,00€

233,00	-	1	1

Alimentação	380V
Potência	1,10Kw
Pressão do trabalho	8-10BAR
Torque máx.	1078Nm
Diâmetro máximo da roda	10-24"
Nível de ruído	75dB
Peso	233,00Kg
Dimensões (CxLxA)	880x435x1880mm



REPOSIÇÕES DISPONÍVEIS

NEW DESMONTADORA DE PNEUS COM TORRE BASCULANTE AUTOMÁTICA E BRAÇO AUXILIAR



VIDEO TUTORIAL

54964

4.399,00€

298,00	-	1	1

Alimentação	220V
Potência	0,75Kw
Pressão do trabalho	8-10BAR
Torque máx.	1078Nm
Diâmetro máximo da roda	10-22"
Nível de ruído	75dB
Peso	298,00Kg
Dimensões (CxLxA)	880x435x1880mm



REPOSIÇÕES DISPONÍVEIS

55022

4.399,00€

298,00	-	1	1

Alimentação	380V
Potência	1,10Kw
Pressão do trabalho	8-10BAR
Torque máx.	1078Nm
Diâmetro máximo da roda	10-24"
Nível de ruído	75dB
Peso	298,00Kg
Dimensões (CxLxA)	880x435x1880mm



REPOSIÇÕES DISPONÍVEIS

54581 2.389,00€

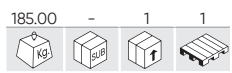

DESMONTADORA DE PNEUS SEMIAUTOMÁTICA



VÍDEO TUTORIAL



REPOSIÇÕES DISPONÍVEIS



Alimentação	220V
Potência	0,75Kw
Pressão do trabalho	8-10BAR
Torque máx.	1078Nm
Diâmetro máximo da roda	10-22"
Nível de ruído	75dB
Peso	184,00Kg
Dimensões (CxLxA)	865x335x1880mm

54582 1.889,00€



EQUILIBRADOR DE RODAS DIGITAL



VÍDEO TUTORIAL



REPOSIÇÕES DISPONÍVEIS



Potência	200W
Tensão máxima de entrada	220V/50Hz
RPM (rotações por minuto)	200
Tempo de trabalho	8s
Carga máxima	65Kg
Diâmetro da roda	10-24"
Largura da jante	1,5-20"
Ruído	<70dB
Peso	75,00Kg
Dimensões (CxLxA)	915x760x1180mm

54970 2.647,50€

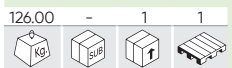

NEW

BALANCEADORA DE RODAS DIGITAL COM PEDAL DE FREIO E LASER

Potência	200W
Tensão	220V/50Hz
Tempo de trabalho	8s
Precisão	±1g
RPM (rotações por minuto)	200
Diâmetro da roda	10-24"
Largura da jante	40-510mm
Ruído	<70db
Peso	103,00Kg
Dimensões (CxLxA)	1178x918x1664mm



REPOSIÇÕES DISPONÍVEIS



53605 154,00€

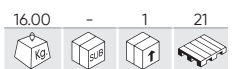

DESMONTADOR DE PNEU MANUAL

Faixa	7½"-16"
Material	S
Peso	16,00Kg
Dimensões (CxLxA)	950x210x200mm



52664

178,00€

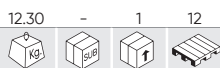

ALAVANCA DE MUDANÇA DE RODAS INDUSTRIAIS



Peças	2
Material	CSTL
Peso	12,30Kg
Dimensões (CxLxA)	740x130x125mm

54198

69,00€

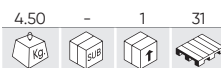

PORTA PNEUS COM RODAS



Capacidade	136Kg
Material	S, PT
Peso	4,50Kg
Dimensões (CxLxA)	660x660x110mm

54136

107,00€

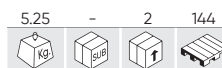

DESMONTADOR DE PNEU MANUAL



Abertura	65mm
Material	S
Peso	5,25Kg
Dimensões (CxLxA)	162x110x257mm

53542

980,00€



DESTANOLADOR PNEUMATICO DE PNEUS



Consumo real de ar	4CFM (113L/min)
Pressão do trabalho	6,2BAR
Velocidade	10000RPM
Entrada de ar	1/4"
Mangueira	3/8"
Abertura	68mm
Percurso	80mm
Material	S, Al
Peso	4,60Kg
Dimensões (CxLxA)	396x320x160mm

52660

126,00€



CARRO PORTA PNEUS, CAP. 200KG



Capacidade	200Kg
Abertura	590mm
Material	S
Peso	7,88Kg
Dimensões (CxLxA)	700x400x750mm

52842

11,00€

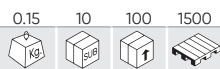

ROLO PARA REPARAÇÃO DA PNEUMÁTICO



Peças	1
Material	S, W
Comprimento	170mm
Diâmetro	38mm
Peso	0,15Kg

53419

10,40€

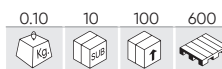

KIT DE 3 PROTETORES DE JANTES



Peças	3
Material	ABS
Comprimento	155mm
Peso	0,10Kg
Dimensões (CxLxA)	155x40x30mm

SEGURANÇA E EPI

426 LUVAS/EPI

430 MEDIDOR DE OZONO

430 DELIMITAÇÃO



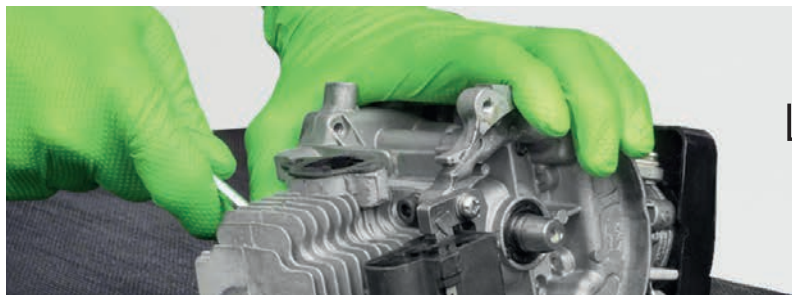

LUVAS DESCARTÁVEIS 100% NITRILO

LUVAS DESCARTÁVEIS DE NITRILO

5MIL - 5.5G

REF.							€
54151	●	M	100PCS	0.60	10	520	9,00€
54152	●	L	100PCS	0.60	10	520	9,00€
54153	●	XL	100PCS	0.60	10	520	9,00€

CUMPRE COM:

GB/T 19001-2016, ISO 9001:2015, ISO 14001:2015, ISO 45001:2018

3.5MIL - 4.2G

REF.							€
54155	●	M	100PCS	0.46	10	570	8,00€
54156	●	L	100PCS	0.50	10	570	8,00€
54157	●	XL	100PCS	0.55	10	570	8,00€

CUMPRE COM:

GBT 19001-2016, ISO 180 9001:2015, ISO 14001:2015, ISO 45001:2018

3.5MIL - 4.2G

REF.							€
53984	●	M	100PCS	0.45	10	500	8,00€
53985	●	L	100PCS	0.50	10	500	8,00€
53986	●	XL	100PCS	0.55	10	500	8,00€

CUMPRE COM:

GBT 19001-2016, ISO 180 9001:2015, ISO 14001:2015, ISO 45001:2018

LUVAS DESCARTÁVEIS DE NITRILO - TEXTURA DIAMANTE

7MIL - 8.4G

REF.							€
54177	●	M	100PCS	0.92	10	310	16,00€
54178	●	L	100PCS	0.96	10	310	16,00€
54179	●	XL	90PCS	0.97	10	310	16,00€

CUMPRE COM:

GBT 19001-2016, ISO 180 9001:2015, ISO 14001:2015, ISO 45001:2018

7MIL - 8.4G

REF.							€
54369	●	M	100PCS	0.90	10	240	16,00€
54370	●	L	100PCS	0.88	10	240	16,00€
54371	●	XL	100PCS	1.05	10	240	16,00€

CUMPRE COM:

GBT 19001-2016, ISO 180 9001:2015, ISO 14001:2015, ISO 45001:2018

7MIL - 8.4G

REF.							€
53551	●	M	100PCS	0.90	10	310	16,00€
53552	●	L	100PCS	1.00	10	310	16,00€
53553	●	XL	90PCS	1.00	10	310	16,00€

CUMPRE COM:

GBT 19001-2016, ISO 9001:2015, ISO 14001:2015, ISO 45001:2018



LUVAS COM PALMA REFORÇADA DE POLIURETANO

REF.						€	
51640N	T.8		0.05	12	144	3456	1,54€
51642N	T.9		0.05	12	144	4320	1,54€
51636N	T.10		0.05	12	144	3456	1,54€
51638N	T.11		0.05	12	144	4320	1,54€

CUMPRE COM:

EN ISO 21420:2020, EN 388:2016+A1:2018



LUVAS COM PALMA REFORÇADA DE NITRILO

REF.						€	
51633	T.8		0.04	12	144	3456	1,54€
51634	T.9		0.05	12	144	3456	1,54€
51632N	T.10		0.05	12	144	3456	1,54€
51398N	T.11		0.05	12	144	2592	1,54€

CUMPRE COM:

EN ISO 21420:2020, EN 388:2016+A1:2018



LUVAS TÉRMICAS DE TRABALHO

REF.						€	
54192	T.8		0.15	12	144	3456	9,60€
54193	T.9		0.10	12	144	3456	9,60€
54194	T.10		0.15	12	144	3456	9,60€
54195	T.11		0.10	12	144	3456	9,60€

CUMPRE COM:

EN ISO 21420:2020, EN 388:2016+A1:2018



LUVAS ANTI-CORTE TACTILES

REF.						€	
52570	T.8		0.03	12	144	3456	2,75€
52571	T.9		0.03	12	144	2592	2,75€
52572	T.10		0.03	12	144	2592	2,75€
52573	T.11		0.04	12	144	2592	2,75€

CUMPRE COM:

EN ISO 21420:2020, EN 388:2016+A1:2018



LUVAS DE COURO

REF.						€	
52738	T.9		0.10	12	144	2304	5,00€
52739	T.10		0.12	12	144	2304	5,00€

CUMPRE COM:

EN 388:2016, EN 420:2003 + A1:2009



LUVAS COM PALMA REFORÇADA DE COURO

REF.						€	
52310	T.10		0.20	12	120	1920	3,90€

CUMPRE COM:

EN 388:2016, EN 420:2003 + A1:2009



LUVAS DE ALGODÃO COM PALMA REFORÇADA DE PONTOS DE BORRACHA

REF.						€
51785	0.04	12	300	3600		1,00€

CUMPRE COM:

EN 420:2003 + A1:2009, EN 388:2016



LUVAS DE TRABALHO

REF.						€
54188	T.8	0.15	12	60	2040	19,00€
54189	T.9	0.15	12	60	720	19,00€
54190	T.10	0.15	12	60	720	19,00€
54191	T.11	0.15	12	60	720	19,00€

CUMPRE COM:

EN 388:2016+A1:2018



ÓCULOS ESPORTIVO DE PROTEÇÃO - ANTI-NEVOEIRO

53596 4,00€

0.01	12	144	2016



EM EXPOSITOR DE 12 UDS

Tipo	Protección solar sport antivaho/Antifog sport protective
Cor	Transparente/Transparent
Normas	EN166:2002-04, EN166:2003-01
Peso	0,01Kg

53597 4,00€

0.01	12	144	2016



EM EXPOSITOR DE 12 UDS

Tipo	Protección solar sport antivaho/Antifog sport protective
Cor	Negro/Black
Normas	EN166:2002-04, EN166:2003-01
Peso	0,01Kg

53598 4,50€

0.01	12	144	2016



EM EXPOSITOR DE 12 UDS

Tipo	Protección solar sport antivaho/Antifog sport protective
Cor	Transparente/Transparent, Negro/Black
Normas	EN166:2002-04, EN166:2003-01
Peso	0,01Kg



52430

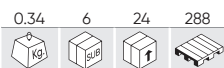

AUSCULTADORES (PASIVO) PARA PROTECÇÃO AUDITIVA

12,60€



Conformidade com a diretiva europeia	EN352-1:2003
Tipo	Protección auditiva/Hearing protection
Peso	0,34Kg
Dimensões (CxLx)A	216x195mm

53785

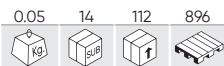

ÓCULOS DE PROTECÇÃO - ANTI-NEVOEIRO

4,80€



Tipo	Protección antivaho/Antifog safety
Cor	Blanco/White
Normas	EN166:2002-04
Peso	0,05Kg

14793

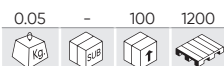

BOMBA DOSEADORA PARA GARRAÇÃO DE 5L

12,00€



53862

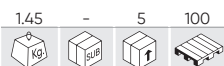

TAPETE COM TANQUE PARA LÍQUIDO DESINFECTANTE

6,00€



Tipo	Para líquido desinfectante/For disinfectant liquid
Capacidade	8L
Material	TPE
Peso	1,45Kg
Dimensões (CxLxA)	850x540x50mm

53863



TAPETE DE SECAGEM

3,00€



Tipo	Para secado/For drying
Material	PL
Peso	0,70Kg
Dimensões (CxLxA)	760x460x20mm

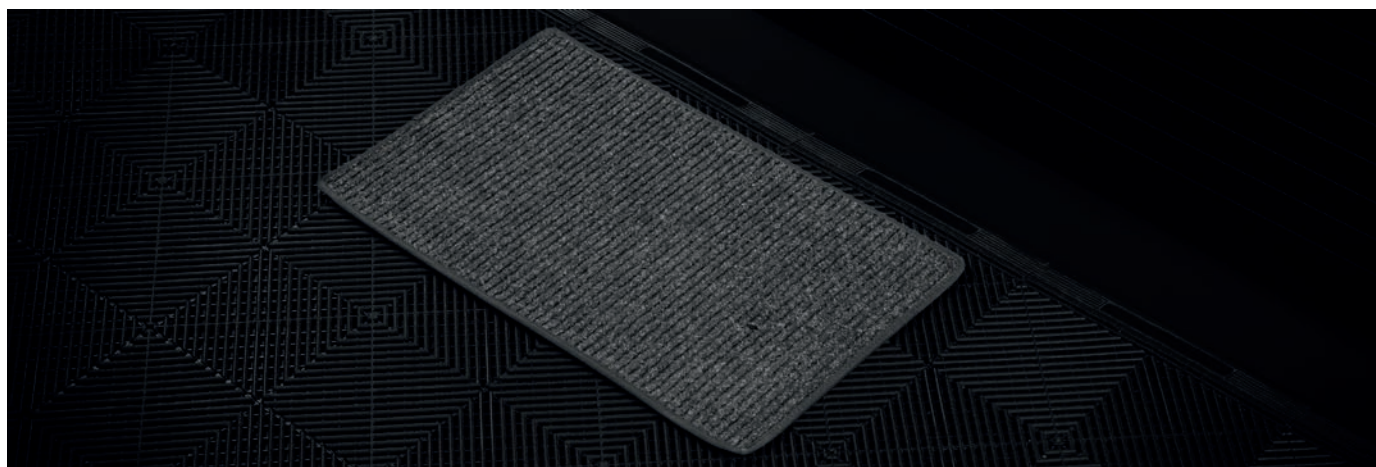

53796

76,00€

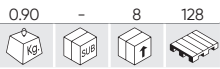

GERADOR DE OZÔNIO PORTÁTIL 600MG/H (12V/220V)



Potência	15W
Tensão	12V
Fluxo de ar	600mg/h
Intensidade do som	45dB
Volume máximo de desinfecção	500m3
Temporizador	1h, Modo retención/Hold mode
Sistema de diluição	Ventilador/Fan
Material	ME, PT
Peso	0,90Kg
Dimensões (CxLxA)	130x180x80mm

53786

98,00€

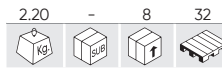

GERADOR DE OZÔNIO PORTÁTIL 5000MG/H (220V)



REPOSIÇÕES DISPONÍVEIS



Potência	60W
Tensão	110-230V
Fluxo de ar	80CFM (2,24m3/min)
Produção de ozônio	5000mg/h
Intensidade do som	45dB
Volume máximo de desinfecção	500m3
Tempo de trabalho necessário para 500m3	120min
Temporizador	2h
Sistema de diluição	Ventilador/Fan
Peso	2,20Kg
Dimensões (CxLxA)	172x187x158mm

DISTÂNCIA DE SEGURANÇA - ESPECIAL VDE

REF.	0.55	-	6	90	€
53940	0.55	-	6	90	15,50€
54326	0.30	-	20	600	8,50€
53987	0.59	-	40	560	10,00€
53942	0.01	50	5000	75000	0,50€
54322	0.05	25	100	-	21,00€



53940



54326



54322

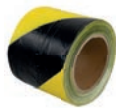

53987



53942

DISTÂNCIA DE SEGURANÇA

REF.	0.55	-	6	114	€
53808	0.55	-	6	114	16,50€
53809	0.30	5	40	960	8,00€
53811	0.45	-	32	576	9,90€
53839	0.01	10	2000	16000	0,34€



53808



53809



53811



53839

CONSUMÍVEIS

- 432** CHAVETAS E ANÉIS DE RETENÇÃO
- 433** REBITES
- 434** PARAFUSOS, PORCAS, ARRUELAS
- 436** ARRUELAS PARA MOTOR E CARTER
- 438** OUTROS
- 439** JUNTAS E ANÉIS DE VEDAÇÃO
- 440** CONECTORES DE MANGUEIRAS
- 441** ELÉTRICOS
- 444** AGRAFOS E PRESILHAS DE PLÁSTICO



52044

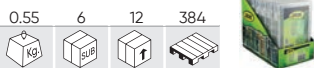

19,00€

ESTOJO DE CLIPS "R" 150 PEÇAS



REPOSIÇÕES DISPONÍVEIS



2,3x43 (x25), 3,2x52 (x20), 3,8x75 (x8), 2x32 (x42), 1,6x36(x30), 1,6x42 (x25)

52027

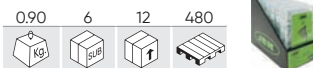

14,00€

ESTOJO DE CAVILHAS DE FENDAS SORTIDAS 365 PEÇAS



REPOSIÇÕES DISPONÍVEIS



1,2x25 (x50), 1,6x32 (x50), 2x40 (x50), 2,5x40 (x50), 3,2x40 (x50), 3,2x50 (x50), 4x50 (x40), 5x63 (x10), 6,3x63 (x15)

53348

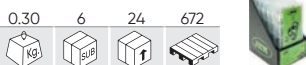

14,00€

ESTOJO DE CIRCLIPI TIPO "E"



M15 - 1/16" (x15), M3 - 1/8" (x15), M5 - 3/16" (x20), M6 - 1/4" (x25), M9 - 3/8" (x25), M12 - 1/2" (x20), M15 - 5/8" (x10), M19 - 3/4" (x10), M22 - 7/8" (x10)

53350



14,00€

ESTOJO DE PASSADORES ELÁSTICOS



1/16" x 3/16" (x4), 1/16" x 5/16" (x4), 1/16" x 3/4" (x4), 5/64" x 1/4" (x4), 5/64" x 1/2" (x4), 5/64" x 1" (x4), 3/32" x 5/8" (x4), 3/32" x 1" (x4), 3/32" x 1-1/4" (x4), 1/8" x 5/8" (x5), 1/8" x 1" (x5), 1/8" x 1-1/4" (x5), 5/32" x 5/8" (x4), 5/32" x 1" (x4), 5/32" x 1-1/2" (x4), 3/16" x 5/8" (x5), 3/16" x 1" (x5), 3/16" x 1-1/4" (x5), 7/32" x 5/8" (x4), 7/32" x 1-1/4" (x4), 7/32" x 1-3/4" (x4), 1/4" x 5/8" (x4), 1/4" x 1-1/4" (x4), 1/4" x 1-3/4" (x4), 5/16" x 3/4" (x4), 5/16" x 1-1/2" (x4), 5/16" x 2" (x4), 3/8" x 3/4" (x2), 3/8" x 1-1/2" (x2), 3/8" x 2" (x2)

53363

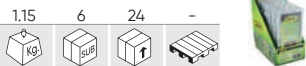

34,00€

ESTOJO DE PASSADORES CLEVIS



3,5x44 (x6), 2,5x42 (x20), 2,5x58 (x7), 2x3 (x7)

8x50 (x5), 9,5x50 (x18), 11x63 (x5), 12,5x50 (x3)

53364



16,00€

CONJUNTO DE 60 CHAVES EM ESTOJO



3x3x25 (x4), 3x3x20 (x4), 5x5x30 (x5), 5x5x25 (x5), 5x5x20 (x5), 6x6x40 (x5), 6x6x30 (x5), 6x6x20 (x5), 8x8x40 (x5), 8x8x30 (x5), 10x10x40 (x5), 10x10x30 (x5), 12x12x40 (x2)

53371

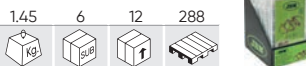

29,00€

ESTOJO DE PASSADORES COM ANILHA



5x36 (x16), 6x45 (x18), 8x45 (x6), 11x45 (x10)

53372



26,50€

ESTOJO DE CHAVETAS



M3x50 (x50), M4x60 (x30), M5x75 (x20), M6x50 (x20), M6x75 (x16), M8x60 (x8)

54873 12,50€

0.35 6 24 720

NEW

ESTOJO COM 20 PINOS CLEVIS



3/8"x1"(x1), 3/8"x2"(x2), 3/8"x2-3/8"(x1), 5/16" x 1-1/2" (x2), 5/16" x 2-1/2" (x2), 5/16" x 1-1/4" (x1), 5/16" x 1" (x1), 5/16" x 2-1/4" (x2), 5/16" x 2" (x2), 5/16" x 3" (x2), 1/4" x 1-1/4" (x1), 1/4" x 1-1/2" (x2), 1/4" x 2" (x1)

54943 15,90€

0.40 6 24 720

NEW

KIT DE 295 UNIDADES - CLIPES, ANÉIS DE RETENÇÃO, CONTRAPINOS, PINOS



3/8" (x12), 1/2" (x12), 5/8" (x12), 3/4" (x12) 1/4" (x20), 3/8" (x20)

1/8x5/8" (x12), 1/8x1"(x12), 5/32x5/8" (x12), 5/32x1" (x12), 3/16x5/8" (x12), 3/16x1" (x12)

3/32x3/8" (x25), 3/32x1/2" (x25), 1/8x1/2" (x25), 1/8x5/8" (x25), 5/32x5/8" (x25), 3/16x3/4" (x10)

54938 12,00€

0.25 6 24 720

NEW

ESTOJO DE ANILHAS PLANAS E DE PRESSÃO 350 PEÇAS



ø3 #6 (x50), ø4 #8 (x40), ø5 #10 (x30), ø6 1/4" (x25), ø8 5/16" (x15), ø 10 3/8" (x15)

ø3 #6 (x50), ø4 #8 (x40), ø5 #10 (x30), ø6 1/4" (x25), ø8 5/16" (x15), ø 10 3/8" (x15)

53373 16,00€

0.25 6 24 672

ESTOJO DE ANILHAS DENTADAS INTERIOR



M3x10 (x30), M4x12 (x30), M5x14 (x40), M6x14 (x50), M8x18 (x50), M10x20 (x40), M12x25 (x20)

53383 11,50€

0.20 6 24 672

ESTOJO DE ANILHAS SEEGER EXTERIORES



M4 (x50), M6 (x40), M8 (x45), M10 (x30), M12 (x30), M14 (x25), M16 (x25), M18 (x25), M20 (x15), M22 (x15)

53382 11,00€

0.15 6 24 672

ESTOJO DE ANILHAS SEEGER INTERIORES



M4 (x50), M6 (x40), M8 (x45), M10 (x30), M12 (x30), M14 (x25), M16 (x25), M18 (x25), M20 (x15), M22 (x15)

52711 32,00€

0.44 - 24 384

ESTOJO DE REBITES PLÁSTICOS 150 PÇS



REPOSIÇÕES DISPONÍVEIS

6x19,3mm (x25), 6x17,8mm (x25), 6x25,5mm (x25), 6x24,5mm (x25), 6x24mm (x50)

52703 22,00€

0.79 6 24 480

ESTOJO DE REBITES FÊMEA 235 PCS



REPOSIÇÕES DISPONÍVEIS

M3 (x50), M4 (x50), M5 (x50), M6 (x50), M8 (x20), M10 (x15), M12 (x10)

53360

0.45 6 24 672



18,00€

ESTOJO DE REBITES PORCA



3x9 (x40), 4x11 (x35), 5x13 (x25), 6x15 (x25), 8x18 (x15), 10x21 (x10)

53361

0.20 6 24 672



24,00€

ESTOJO DE REBITES PORCA DE ALUMÍNIO



3x9 (x40), 4x11 (x35), 5x13 (x25), 6x15 (x25), 8x18 (x15), 10x21 (x10)

52043

0.80 6 12 384



18,00€

ESTOJO DE REBITES 300 PEÇAS



REPOSIÇÕES DISPONÍVEIS



4,8x16,90mm (x50), 4,8x24,80mm (x40), 3,2x9,70mm (x90), 4,8x12,70mm (x70), 4,80x20mm (x50)

54932

0.33 6 24 504

NEW

12,50€

SORTIDO DE PARAFUSOS PRISIONEIRO COM CABEÇA SEXTAVADA INTERNA SAE 160 PEÇAS

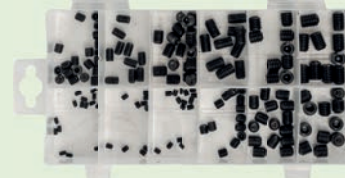

4-40x3/16" (x15), 1/4"-20 x 1/4" (x20), 8-32 x 3/16" (x15), 1/4"-28 x 1/4" (x15), 10-24 x 1/4" (x10), 1/4"-20 x 3/8" (x10), 5/16"-18 x 3/8" (x20), 3/8"-16 x 3/8" (x10), 5/16"-24 x 3/8" (x15), 3/8"-16 x 1/2" (x10), 5/16"-18 x 1/2" (x10), 3/8"-24 x 3/8" (x10)

54933

0.34 6 24 504

NEW

9,00€

SORTIDO DE PARAFUSOS PRISIONEIRO COM CABEÇA SEXTAVADA INTERNA MÉTRICOS 160 PEÇAS

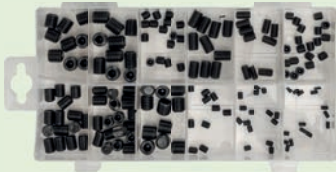

3x5mm (x15), 4x5mm (x15), 5x6mm (x10), 6x6mm (x20), 6x6mm F (x15), 6x10mm (x10), 8x10mm (x20), 8x10mm F (x15), 8x12mm (x10), 10x10mm (x10), 10x10mm F (x10), 10x12mm (x10)

54939

0.30 6 24 720

NEW

10,50€

ESTOJO DE ANILHAS GROWER E DENTADAS 720 PEÇAS

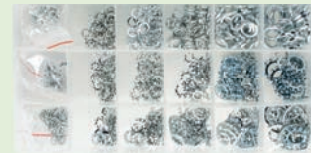

#6 (x50), #8 (x50), #10 (x50), 1/4" (x40), 5/16" (x30), 3/8" (x20)
#6 (x50), #8 (x50), #10 (x50), 1/4" (x40), 5/16" (x30), 3/8" (x20)
#6 (x50), #8 (x50), #10 (x50), 1/4" (x40), 5/16" (x30), 3/8" (x20)

53351

0.90 6 12 -



14,00€

ESTOJO DE PARAFUSOS E PORCAS



M4x12 (x10), M4x20 (x10), M5x16 (x10), M5x25 (x10), M6x20 (x10), M6x30 (x10), M8x25 (x5), M8x40 (x5), M10x16 (x5), M10x40 (x5)
M4 (x20), M5 (x20), M6 (x20), M8 (x10), M10 (x10)
M4 (x20), M5 (x20), M6 (x20), M8 (x10), M10 (x10)



53354

14,00€

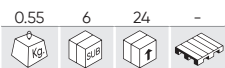

ESTOJO DE PARAFUSOS AUTORROSCANTES



#8x12.5 (x30), #8x16 (x30), #8x19 (x30), #8x25 (x30), #10x12.5 (x20), #10x16 (x20), #10x19 (x20), #10x25 (x20)

53362

14,00€

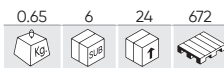

ESTOJO DE PARAFUSOS ALLEN



4x12 (x25), 5x12 (x25), 5x25 (x20), 10x40 (x3), 6x25 (x10), 8x40 (x5), 10x25 (x3), 6x12 (x10), 8x25 (x5)

53365

16,00€

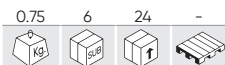

ESTOJO DE PORCAS BOLBOLETA



M4 (x40), M5 (x40), M6 (x25), M8 (x25), M10 (x20)

53366

15,00€

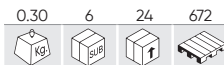

ESTOJO DE PARAFUSOS E PORCAS TIPO U



M3.5x8 (x40), M4.2x16 (x20), M5x12 (x15), M6.35x19 (x10)
 M3.5 (x20), M3.5 Con muesca/with notch (x20), M4 (x20), M5 (x15), M6.35 (x10)

53369

16,00€

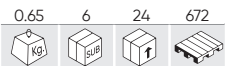

ESTOJO DE PARAFUSOS



2.8x13mm (x65), 2.8x16mm (x55), 3.5x10mm (x60), 3.5x13mm (x65), 3.5x16mm (x60), 3.5x19mm (x45), 4.2x13mm (x50), 4.2x16mm (x40), 4.2x25mm (x30), 4.2x31mm (x20), 4.8x19mm (x25), 4.8x25mm (x20), 4.8x32mm (x15)

52029

14,00€

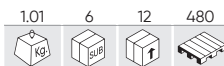

ESTOJO DE PORCAS AUTOBLOCANTES 228U.

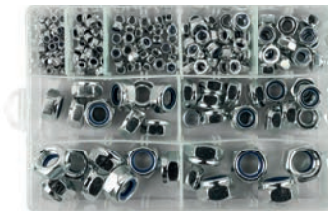

M3 (x50), M4 (x50), M5 (x40), M6 (x30), M8 (x20), M10 (x15), M12 (x10), M14 (x8), M16 (x5)

52028

16,50€

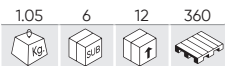

ESTOJO DE PORCAS 243 PEÇAS



REPOSIÇÕES DISPONÍVEIS



M3 (x50), M4 (x50), M5 (x50), M6 (x30), M8 (x20), M10 (x20), M12 (x10), M14 (x8), M16 (x5)

52032

30,00€

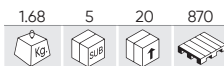

ESTOJO DE ANILHAS DE PRESSÃO PRETAS - 1.735U.



3mm (x600), 4mm (x400), 5mm (x220), 6mm (x220), 8mm (x110), 10mm (x65), 12mm (x50), 14mm (x40), 16mm (x30)

52158

38,50€



ESTÔJO DE ANILHAS DE FERRO GALVANIZADO, 475PCS



- 5x20x1.5 (x50), 6x20x1.5 (x50), 7x20x1.5 (x50), 8x20x1.5 (x50), 8x25x1.75 (x50), 10x30x2.5 (x25), 6x30x2 (x25), 7x30x2 (x25), 8x30x2 (x25), 4x11x0.98 (x50), 12x40x3 (x25), 4x20x1.5 (x50)

53377

22,00€

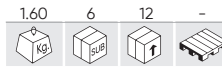

ESTOJO DE ANILHAS DE FERRO SOBRE-MEDIDAS



- 20x6x1.5 (x20), 20x8x1.5 (x20), 20x10x1.5 (x20), 25x6x1.5 (x20), 25x8x1.5 (x20), 25x10x1.5 (x20), 32x2x1.5 (x20), 32x4x1.5 (x20), 32x6x1.5 (x20), 32x8x1.5 (x20), 32x10x1.5 (x20), 32x10x1.5 (x20)

53464

153,00€

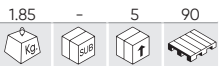

SORTIMENTO DE ANILHAS DE COBRE PARA INJETORES 551 PCS

Ø15.0x8.0x1.5 - UNIVERSAL	30	Ø13.0x7.0x1.5 - DEUTZ	12
Ø15.0x7.0x1.5 - MERCEDES	12	Ø13.5x7.5x1.5 - FORD	30
Ø13.0x7.5x2.5 - RENAULT	30	Ø15.0x7.5x1.5 - FIAT	12
Ø15.0x7.5x1.5 - IVECO, FORD, BMW, MAN	30	Ø15.5x7.5x1 - MAN ROVER	12
Ø15.0x7.5x2.0 - IVECO, FORD, BMW, MAN	30	Ø16.5x7.5x2 - MERCEDES	30
Ø15.45x8.0x2.0 - UNIVERSAL	30	Ø13.7x7.3x3 - KIA	12
Ø13.5x10x2.0 - MAZDA (REF.. 53464)	12	Ø13.7x7.3x2 - KIA	12
Ø15.5x7.5x2.5 - FORD	30	Ø10x6.0x1.0	50
Ø15.5x7.5x1.5 - LAND ROVER	12	Ø15.8x7.5x3.0	30
Ø15.0x7.5x3.0 - RENAULT	30	SACO DE 30 CONECTORES DE MANGUEIRA EM "T"	20



REPOSIÇÕES DISPONÍVEIS

Ø8x5.8x1	30
SACO DE 30 CONECTORES DE MANGUEIRA EM "L"	30
SACO DE 30 RETENÇÃO SPRINGS	25

52031

45,50€

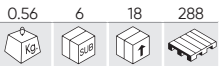

SORTIMENTO DE ANILHAS ALUMÍNIO 900 PEÇAS



- 3x7x1.5 (x50), 4x8x1.5 (x50), 5x6x1.5 (x50), 16x22x1.5 (x50), 14x22x1.5 (x50), 14x20x1.5 (x50), 6x10x1.5 (x50), 6x11x1.5 (x50), 7x11x1.5 (x50), 7x12x1.5 (x50), 8x12x1.5 (x50), 8x14x1.5 (x50), 9x12x1.5 (x50), 10x14x1.5 (x50), 11x16x1.5 (x50), 11x17x1.5 (x50), 12x16x1.5 (x50), 12x18x1.5 (x50)

53353

18,00€

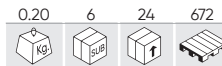

SORTIMENTO DE ANILHAS DE COBRE



- M6 (x30), M8 (x25), M10 (x20), M12 (x15), M14 (x10), M16 (x10)

54918

24,50€

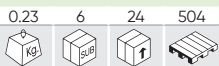

NEW

ESTOJO DE ANILHAS PARA BUJÃO DO CÂRTER FORD 120 PEÇAS



- 12x25x1.2mm (x20), 14x25x1.5mm (x20)
- 12x22x2mm (x20), 14x24x2mm (x20)
- 12x21x2.5mm (x20), 14x22x2.5mm (x20)

54929

14,50€

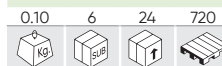

NEW

ESTOJO DE ANILHAS DE FIBRA E NYLON 60 PEÇAS



- 1/2" (x20), 16mm (x5), 18mm (x5), 20mm (x5)
- 1/2" (x10), 12mm (x10), 14mm (x10)

54930 47,00€

0.42 6 24 720

NEW

ESTOJO DE BUJÕES DE DRENO DE ÓLEO SOBREDIMENSIONADOS

1/2"-20"(x6), M14-1.5 (x2)
 1/2"-20"(x4)
 M14x24 (x5), 1/2"- 13.5x19 (x5), 1/2"-15x21 (x5)

54931 63,00€

0.50 6 12 720

NEW

ESTOJO DE BUJÕES DE DRENO DE ÓLEO 40 PEÇAS

12mm-1.25 (x3), 12mm-1.75 (x3), 14mm-1.5 (x3)
 12mm-1.75 (x3), 14mm-1.5 (x3), 14mm-1.5 (x5), 1/2"-20 (x3), 12mm-1.75 (x3)
 12mm-1.75 (x3), 14mm-1.5 (x3), 14mm-1.5 (x5)

52163 95,00€

0.65 6 18 288

SORTIMENTO DE ANILHAS DE COBRE PARA BUJÕES DE CÂRTER

REPOSIÇÕES DISPONÍVEIS

10mm (x100), 12mm (x100), 14mm (x100), 16mm (x100), 18mm (x100), 20mm (x25)

52030 104,00€

1.21 6 12 288

CONJUNTO DE ANILHAS DE COBRE 900 PCS

REPOSIÇÕES DISPONÍVEIS

3x7x1,5 (x50), 4x8x1,5 (x50), 5x6x1,5 (x50), 16x22x1,5 (x50), 14x22x1,5 (x50), 14x20x1,5 (x50), 6x10x1,5 (x50), 6x11x1,5 (x50), 7x11x1,5 (x50), 7x12x1,5mm (x50), 8x12x1,5 (x50), 8x14x1,5 (x50), 9x12x1,5 (x50), 10x14x1,5 (x50), 11x16x1,5 (x50), 11x17x1,5 (x50), 12x16x1,5 (x50), 12x18x1,5 (x50)

53229 38,70€

0.40 5 10 640

SORTIMENTO DE ANILHAS DE COBRE PARA INJETOR 150 PCS

REPOSIÇÕES DISPONÍVEIS

13,8x7,3x1,4 (x10), 14,6x7,5x1,3 (x10), 14,6x7,5x3,0 (x10), 15,0x7,0x2,0 (x10), 15,0x7,5x1,0 (x10), 15,0x7,5x1,5 (x10), 15,0x7,5x2,0 (x10), 15,0x7,5x2,5 (x10), 15,0x7,5x3,0 (x10), 15,5x7,5x2,0 (x10), 16,0x7,5x1,5 (x10), 16,0x7,5x1,7 (x10), 16,0x7,5x2,0 (x10), 16,4x7,5x2,0 (x10), 20,0x9,4x0,9 (x10)

53340 92,00€

0.90 5 10 1050

SORTIMENTO DE ANILHAS DE COBRE PARA INJETORES 375 PCS

REPOSIÇÕES DISPONÍVEIS

13,8x7,3x1,4 (x25), 14,6x7,5x1,3 (x25), 14,6x7,5x3,0 (x25), 15,0x7,0x2,0 (x25), 15,0x7,5x1,0 (x25), 15,0x7,5x1,5 (x25), 15,0x7,5x2,0 (x25), 15,0x7,5x2,5 (x25), 15,0x7,5x3,0 (x25), 15,5x7,5x2,0 (x25), 16,0x7,5x1,5 (x25), 16,0x7,5x1,7 (x25), 16,0x7,5x2,0 (x25), 16,4x7,5x2,0 (x25), 20,0x9,4x0,9 (x25)

ANILHAS PARA BUJÃO DE CÂRTER FERRO-BORRACHHA

REF.	DESCRIÇÃO					€
52719	ø 10mm	0.01	100	5000	150000	0,19€
51843	ø 12mm	0.01	100	5000	200000	0,19€
51554	ø 13mm	0.01	100	5000	180000	0,30€
51546	ø 14mm	0.01	100	5000	150000	0,19€
51799	ø 16mm	0.01	100	2500	-	0,20€

REF.	DESCRIÇÃO					€
51538	ø 10mm	0.01	100	5000	-	0,15€
51539	ø 12mm	0.00	100	5000	-	0,18€
51540	ø 14mm	0.01	100	5000	-	0,19€
51541	ø 16mm	0.01	100	5000	-	0,25€
51542	ø 18mm	0.01	100	5000	-	0,25€
51543	ø 20mm	0.01	100	2000	-	0,30€
51544	ø 22mm	0.01	100	3000	-	0,30€
51545	ø 26mm	0.01	100	2000	-	0,36€



54390

199,00€

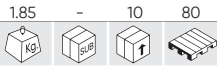

CONJUNTO DE CONECTORES E TUBOS DE COMBUSTÍVEL (95 PÇS)

	6.3x6mm (x3), 7.89x8mm (x3), 9.49x8mm (x3), 9.89x8mm (x3), 11.80x10mm (x3)
	6.3x6mm (x3), 7.89x8mm (x3), 9.49x8mm (x3), 9.89x8mm (x3), 11.8x10mm (x3)
	6.3x6mm (x5), 7.89x8mm (x5), 9.49x8mm (x5), 9.89x8mm (x5), 11.8x10mm (x5)
	6x7.5mm (x3), 8x7.5mm (x6), 7.5x200mm (x3), 12x200mm (x1), 6x340mm (x2), 8x340mm (x6), 9.5x340mm (x2)
	15-18mm (x12), 17-20mm (4)



REPOSIÇÕES DISPONÍVEIS



53599

31,00€

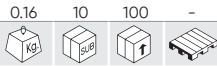

KIT DE VÁLVULAS PARA O AR CONDICIONADO



REPOSIÇÕES DISPONÍVEIS



5x19mm R12 (x50)	5x19mm R12 (x30)	5x19mm (x30)	6x19mm (x3)	6x26mm (x1)	7x20mm R134A (x10)	6x22mm (x5)	8x22mm (x1)	9x22mm (x4)
------------------	------------------	--------------	-------------	-------------	--------------------	-------------	-------------	-------------

53378

15,00€

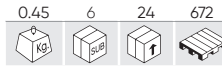

ESTOJO DE ABRAÇADEIRAS DE TUBO 20 PEÇAS



1" (x4)	2-1/2" (x2)	1-1/4" (x2)	3" (x2)	1-3/4" (x2)	3-1/2" (x2)	2" (x4)	4" (x2)
---------	-------------	-------------	---------	-------------	-------------	---------	---------

53358

11,50€

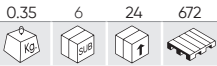

ESTOJO DE MOLAS – 200 PCS



5/16x1-3/4 (x12)	9/32x1/2 (x10), 1/4x13/32 (x10), 7/32x11/16 (x10), 7/32x1-1/2 (x10), 3/8x5/8 (x6), 3/8x3/4 (x12), 23/64x1-3/8 (x8), 9/32x3/4 (x10)
13/64x13/16 (x10), 7/32x1 (x10), 1/4x7/8 (x10), 5/16x1-1/8 (x8), 5/16x1-1/4 (x10), 3/16x1-3/4 (x8), 9/32x1-1/2 (x10), 11/32x1-7/16 (x10), 11/32x1-27/32 (x12), 9/32x2 (x12), 5/32x3-1/8 (x12)	

53352

12,00€

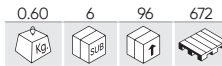

ESTOJO DE PARAFUSOS DE GANCHO



2.4x41 (x50)	4x64 (x12)	4.2x85 (x5)
2.4x25 (x60)	4x45 (x12)	4x50 (x12)

52033

46,00€

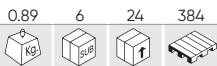

ESTOJO DE BICOS PARA ENGRASSAR – 135 PEÇAS



REPOSIÇÕES DISPONÍVEIS

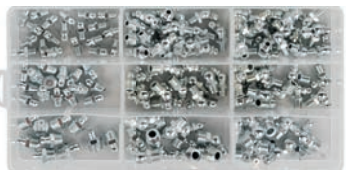

90°: 6x1 (x20), 8x1 (x15), 10x1 (x10)
0°: 6x1 (x20), 8x1 (x15), 10x1 (x10)
45°: 6x1 (x20), 8x1 (x15), 10x1 (x10)

53359

17,00€

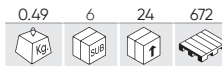

ESTOJO DE LUBRIFICADORES 110 PEÇAS



90°: 6x1 (x60), 8x1.25 (x10), 10x1.5 (x10)
0°: 6x1 (x5), 8x1.25 (x5), 10x1.5 (x5)
45°: 6x1 (x5), 8x1 (x5), 10x1 (x5)

54944 17,50€

0.30 6 24 720

NEW

CONJUNTO DE GRAMPOS DE BORRACHA 42PCS

$5/16''$ (x8), $3/8''$ (x6), $1/4''$ (x20), $1/2''$ (x4), $5/8''$ (x4)

54937 21,00€

0.60 6 24 720

NEW

ESTOJO DE MOSQUETÕES COM ROSCA 20 PEÇAS

$1-3/8'' \times 11/16''$ (x6), $1-5/8'' \times 3/4''$ (x4), $3'' \times 1-5/16''$ (x2), $2-9/16'' \times 1-1/4''$ (x2), $1-15/16'' \times 7/8''$ (x4), $2-3/4'' \times 1-1/16''$ (x2)

54935 23,00€

0.40 6 12 720

NEW

ESTOJO DE ABRAÇADEIRAS MINI PARA MANGUEIRAS 56 PEÇAS

6-8mm (x10), 9-11mm (x10), 11-13mm (x10), 14-16mm (x10), 16-18mm (x10), 19-21mm (x6)

54936 12,50€

0.30 6 24 720

NEW

ESTOJO DE ABRAÇADEIRAS PARA TUBOS 34 PEÇAS

$5/8''$ (16mm) (x8), $3/4''$ (19mm) (x8), $7/8''$ (22mm) (x6), $1-1/4''$ (32mm) (x4), $1''$ (25mm) (x4), $1-1/16''$ (28mm) (x4)

53381 16,00€

0.19 6 12 384

SORTIMENTO DE ANILHAS DE FIBRA 600 PEÇAS

$10 \times 5.5 \times 1$ (x160), $16 \times 10 \times 1$ (x80), $19 \times 12 \times 1$ (x40), $22 \times 16 \times 1$ (x30), $22.5 \times 14 \times 1$ (x20), $32 \times 22 \times 1$ (x20), $12 \times 6.5 \times 1$ (x100), $16 \times 8 \times 1$ (x60), $20 \times 12.5 \times 1$ (x40), $27 \times 20 \times 1$ (x20), $25.4 \times 17.5 \times 1$ (x15), $32 \times 24 \times 1$ (x15)

54946 12,50€

0.15 6 24 720

NEW

CONJUNTO DE ANILHAS DE VEDAÇÃO 141PCS

$1/2'' \times 17mm$ (x5), $3/8'' \times 8mm$ (x5), $1/2'' \times 16mm$ (x10), $1/2'' \times 19mm$ (x10), $3/4'' - 11 \times 24 \times 2mm$ (x10), $3/4'' - 15 \times 24mm$ (x10), $1/4''$ (x5), $3/8'' \times 10mm$ (x5), $1/2'' \times 10mm$ (x5), $3/8'' \times 10$, $21 \times 17mm$ (x10), $3/8'' \times 8mm$ (x10), $3/4''$, $16 \times 24mm$ (x3), $1-1/2''$, $27 \times 38mm$ (x3), $1/2''$ (x10), $1/2''$, $12 \times 18mm$ (x5), $1-1/4''$, $30 \times 39mm$ (x5), $1''$ (x5)



50807 38,00€

0.16 6 24 768

KIT DE O'RINGS PARA AACC

5.29×1.78 (x20), 6.07×1.78 (x20), 6.8×1.9 (x20), 7.65×1.78 (x20), 7.80×1.90 (x20), 8.0×2.0 (x20), 8.80×1.90 (x20), 10.82×1.78 (x15), 10.77×2.62 (x15), 11.0×2.0 (x15), 12.0×2.0 (x15), 13.9×1.80 (x10), 13.95×2.62 (x10), 14.0×2.0 (x10), 15.0×2.0 (x10), 17.0×2.0 (x10), 17.17×1.78 (x10), 17.04×3.53 (x10)

50651

20,00€

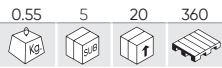

SORTIMENTO DE O'RINGS MÉTRICAS

	TAPA DEL ESTUCHE						BAZA TRUSEI					
Posição no estôjo	006	007	008	009	010	011	211	212	213	214	215	216
Larg. borracha (mm)	2	2	2	2	2	2	3	3	3	3	3	3
Ø Interior (mm)	3	4	5	6	7	8	20	22	24	25	27	28
Quantidade	16	16	16	16	16	16	12	12	12	12	12	12
Posição no estôjo	113	112	111	110	012		221	220	219	218	217	
Larg. borracha (mm)	2.5	2.5	2.5	2.5	2		3	3	3	3	3	
Ø Interior (mm)	14	12	11	10	10		36	35	33	32	30	
Quantidade	13	13	13	13	17		12	12	12	12	12	
Posição no estôjo	114	115	116	210			222	325	326	327		
Larg. borracha (mm)	2.5	2.5	2.5	3			3	4	4	4		
Ø Interior (mm)	16	17	19	19			38	38	41	44		
Quantidade	13	13	13	10			12	10	9	9		



50652

20,00€

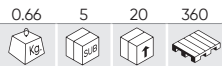

SORTIMENTO DE O'RINGS PULGADAS

	TAPA DEL ESTUCHE						BAZA TRUSEI					
Posição no estôjo	006	007	008	009	010	011	211	212	213	214	215	216
Larg. borracha (mm)	1/16	1/16	1/16	1/16	1/16	1/16	1/8	1/8	1/8	1/8	1/8	1/8
Ø Interior (mm)	1/8	5/32	3/16	7/32	1/4	5/16	13/16	7/8	15/16	1	11/16	11/8
Quantidade	20	20	20	20	20	20	10	10	10	10	10	10
Posição no estôjo	113	112	111	110	012		221	220	219	218	217	
Larg. borracha (mm)	3/32	3/32	3/32	3/32	1/16		1/8	1/8	1/8	1/8	1/8	
Ø Interior (mm)	9/16	1/2	7/16	3/8	3/8		17/16	13/8	15/16	11/4	13/16	
Quantidade	13	13	13	13	13		10	10	10	10	10	
Posição no estôjo	114	115	116	210			222	325	326	327		
Larg. borracha (mm)	3/32	3/32	3/32	1/8			1/8	3/16	3/16	3/16		
Ø Interior (mm)	5/8	11/16	3/4	3/4			11/2	11/2	15/8	13/4		
Quantidade	13	13	13	10			10	7	7	7		



53910

19,00€

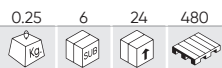

ESTOJO DE CONECTORES DE MANGUEIRA 113 PEÇAS

RETO		TUBO EM T	
4.8x4.8	10	3.9x3.9x3.9	8
6.3x6.3	8	4.8x4.8x4.8	8
7.9x7.9	6	6.3x6.3x6.3	6
9.5x9.5	6	9.5x9.5x9.5	3
3.17x3.17	30	3.17x3.17x3.17	12

REDUTOR	
9.5x6.3	6
6.3x4.8	10



53434

18,00€

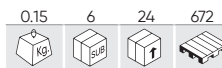

ESTOJO DE CONECTORES DE MANGUEIRA 65 PEÇAS

PCS	
4x28.7	10
3.9x30.8	5
10.4x44	10
5.6x47.1	5
7.9x38	10
4.7x38.9	5
5.2x33.9	10
7x30	10



54830 52,00€

0.26 5 20 400

NEW

ESTOJO COM 85 CONECTORES DE RETORNO PARA SISTEMAS DIESEL



43x24mm (x5), 30,5x24mm (x10), 23,5x22,4mm (x15), 22x19,5mm (x15), 31x33mm (x10), 33,3x17,5mm (x10), 22x17,5mm (x15), 48x36,2mm (x5)

53992 18,00€

0.10 6 84 1512



ESTOJO DE MANGAS DE SOLDA TERMOENCOLHÍVEIS 100PCS



Ø1.7mm / 0.25-0.34mm ² / 26-24 AWG	25
Ø2.7mm / 0.5-1.0mm ² / 22-18 AWG	35
Ø4.7mm / 1.5-2.5mm ² / 16-14 AWG	30
Ø6.0mm / 4.0-6.0mm ² / 12-10 AWG	10

53374 10,00€

0.15 6 24 672



ESTOJO DE TUBOS TERMO-RETRACTÍLES

REF.	PCS
M2x40	30
M2.5x40	25
M3.5x40	20
M5x40	20
M7x80	16
M10x80	8
M13x85	8



53376 10,50€

0.15 6 24 816



ESTOJO DE TUBOS TERMO-RETRACTÍLES VERMELHOS

REF.	PCS
M2x40	30
M2.5x40	25
M3.5x40	20
M5x40	20
M7x80	16
M10x80	8
M13x85	8



REF. DESCRIÇÃO

51920 MAÇARICO

€
 0.14 10 100 400 18,00€

53349 14,00€

0.25 6 24 672



ESTOJO DE PASSA-CABOS DE BORRACHA

ABERTOS	PCS	FECHADOS	PCS
M19,5x23	2	M25	2
M16x24	3	M22	3
M13x15	3	M19	4
M11,5x19	4	M15	5
M10x20	3	M12	10
M10x12	5	M9	20
M9,8x11,5	6	M7	20
M8x14	3		
M7,5x13	7		
M6x7,5	10		
M3,5x6	15		



53370 26,00€

0.30 6 12 -



ESTOJO DE PASSA-CABOS DE BORRACHA - M2,3,4,5,6,8,10

REF.	PCS
M2	25
M3	25
M4	30
M5	30
M6	30
M8	20
M10	20



54941

10,90€

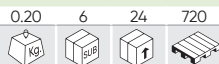

NEW

CONJUNTO DE CLIPES ELÉTRICOS 28PCS



- 38mm (x3) 50mm (x3) ■ 10AMP (x1), 25AMP (x1), 30AMP (x1)
- 38mm (x3) 50mm (x3) ■ 10AMP (x1), 25AMP (x1), 30AMP (x1)
- Mini (x10)

54942

14,90€



NEW

CONJUNTO DE 65 UNIDADES DE JUNÇÃO RÁPIDA DE FIOS



- 22-18 A.W.G. (x20) ■ 18-14 A.W.G. (x20)
- 18-14 A.W.G. (x20) ■ 12-10 A.W.G. (x5)

54940

13,00€

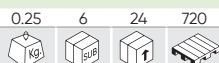

NEW

KIT DE CONECTOR DE CABO ROSCADO 158PCS



- 2x#22 (x20), 2x#16 (x20) ■ 2x#18 (x9), 4x#14 & 1x#18 (x9)
- 2x#22 (x20), 3x#16 (x20) ■ 2x#14 (x5), 2x#10 & 2x#12 (x5)
- 1x#18 & 1x#20 (x25), 4x#16 & 1x#20 (x25)

53355

11,50€

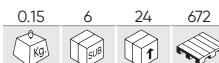

ESTOJO DE FUSÍVEIS MINI



- 5A (x20), 10A (x20), 15A (x20), 20A (x20), 25A (x20), 30A (x20)

53356

12,00€

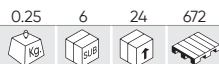

ESTOJO DE FUSÍVEIS



REPOSIÇÕES DISPONÍVEIS



- 5A (x20), 10A (x20)
- 20A (x20), 25A (x20), 30A (x20)
- 15A (x20)

53367

9,50€



ESTOJO DE FUSÍVEIS DE 48 U



- 5A (x8), 10A (x8), 15A (x8)
- 20A (x8), 25A (x8), 30A (x8)

53368

9,00€

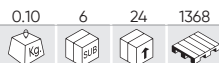

ESTOJO DE FUSÍVEIS DE 50 U.



- 5A (x8), 10A (x8), 15A (x8), 20A (x8), 25A (x8), 30A (x10)

53380

12,40€

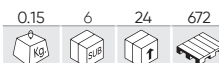

ESTOJO DE FUSÍVEIS



- 5A (x20), 10A (x20), 15A (x20), 20A (x20), 25A (x20), 30A (x20)

52053

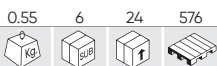

ESTOJO DE TERMINAIS 635 PEÇAS

	RV1.25-4S		50		FDD1.25-250		45
	RV2-4S		50		FDD2-250		40
	RV2-6S		30		FDD5.5-250		25
	RV5.5-6S		20		MDD1.25-250		50
	RV5.5-5S		20		MDD2-250		50
	RV2-5S		40		MDD5.5-250		30
	BV5.5		15		SV1-4S		50
	BV2		25		SV2-4S		40
	BV1.25		30		DFDN 1.25-250		25

45,00€



REPOSIÇÕES DISPONÍVEIS

52054



ESTOJO DE FUSÍVEIS 252 PEÇAS

	3A		20		4A		8
	4A		20		5A		8
	5A		20		3A		8
	7.5A		20		7.5A		8
	10A		20		10A		8
	15A		20		15A		8
	20A		20		20A		8
	25A		20		25A		8
	30A		20		30A		8

17,00€



REPOSIÇÕES DISPONÍVEIS

53357

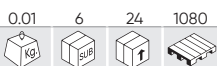

7,00€

KIT DE 2 PINÇAS DE CROCODILO



Peças	2
Amperes	30AMP
Comprimento	100mm
Peso	0,01Kg

53385

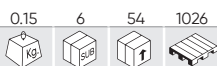

19,30€

ALICATE PARA EXTRAÇÃO DE GRAMPOS DE CARROCERIA



Peças	1
Material	Cr-V
Comprimento	170mm
Abertura	27mm
Peso	0,15Kg

52851

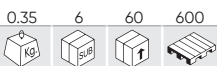

9,65€

JOGO DE 2 ALAVANCAS PARA EXTRAÇÃO DE GRAMPOS



Peças	2
Peso	0,35Kg
Dimensões (CxLxA)	310x103x30mm

53110

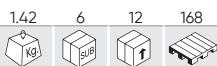

29,50€

KIT DE 6 ALAVANCAS



Peças	6
Peso	1,42Kg
Dimensões (CxLxA)	600x250x40mm



UNIDADES NO CASO



UNIDADES POR SACO DE PEÇAS SOBRESSALENTES



APRESENTAÇÃO EM UM EXPOSITOR

52896

27,50€



SORTIMENTO DE CLIPS PARA MAZDA 190PCS

REF.	DESCRIÇÃO			€/kg
13104	OE:2042301	8	8	3,70€
13105	OE:999100402	15	15	5,60€
13106	OE:B0016830200	8	8	4,40€
13107	OE:N30413356A	8	8	4,40€
13108	OE:992640543A	20	20	4,10€
13109	OE:99249051B	30	30	6,30€
13110	OE:6508197AA	15	15	3,90€
13111	OE:B1016825200	10	10	2,45€
13112	OE:B09251833	6	6	2,75€
13113	OE:992640543A	20	20	4,80€
13114	OE:B45556741	20	20	4,75€
13115	OE:G03158762	30	30	5,30€



INFORMAÇÕES TÉCNICAS



52886

18,00€



SORTIMENTO DE CLIPS PARA LEXUS / TOYOTA 89 PCS

REF.	DESCRIÇÃO			€/kg
13002	OE:9018906001	8	8	2,65€
13003	OE:9046707138	5	4	3,70€
13004	OE:9046707117	10	10	3,40€
13005	OE:9046709138	10	10	2,60€
13006	OE:9046709101	5	5	2,75€
13007	OE:75521611000	10	10	2,75€
13008	OE:7503933060	8	8	5,00€
13009	OE:9017905060	4	4	3,70€
13010	OE:677711250	8	8	3,05€
13011	OE:9046708124	5	5	2,55€
13012	OE:7539533030	8	8	4,00€
13013	OE:9046711063	8	8	3,90€



INFORMAÇÕES TÉCNICAS



52887

22,00€



SORTIMENTO DE CLIPS PARA HONDA 150 PCS

REF.	DESCRIÇÃO			€/kg
13014	OE:75103S.J4003	12	12	3,15€
13015	OE:90675SB003	5	5	2,45€
13016	OE:91566SP0003	6	6	2,45€
13017	OE:91513SE003	25	25	5,60€
13018	OE:91530ST5003	25	25	2,90€
13019	OE:90687SA50030	15	15	3,70€
13020	OE:91620SR2003	8	8	3,80€
13021	OE:38529689A6300	8	8	2,85€
13022	OE:90683SA5003	10	10	4,00€
13023	OE:90672671003	10	10	3,25€
13024	OE:91534SEO000	18	18	5,40€
13025	OE:34355SD2003	8	8	3,35€



INFORMAÇÕES TÉCNICAS





52899

34,00€

0.50 6 24 336



SORTIMENTO DE CLIPS PARA PEUGOT / CITROEN 345 PCS

REF.	DESCRIÇÃO			€/△
13128	OE:947098	50	50	3,70€
13129	OE:856535	20	20	4,40€
13130	OE:6991W4	20	20	7,90€
13131	-	20	20	5,40€
13132	OE:694143	25	25	5,30€
13133	OE:743707	35	35	7,70€
13134	OE:7703074022	30	30	8,90€
13135	OE:7703077059	35	35	7,70€
13136	OE:698317	15	15	5,50€
13137	OE:699502	25	25	4,95€
13138	OE:6995X3	30	30	5,50€
13139	OE:69945	40	40	8,50€



INFORMAÇÕES TÉCNICAS



52900

34,50€

0.50 6 24 288



SORTIMENTO DE CLIPS PARA FIAT 308 PCS

REF.	DESCRIÇÃO			€/△
13140	OE:14591784	30	30	5,70€
13141	OE:1459487	20	10	3,90€
13142	OE:1300433650	25	25	6,50€
13143	OE:71717421	8	8	4,50€
13144	OE:82456515	25	25	4,75€
13145	OE:5757139	25	25	8,50€
13146	-	20	8	9,90€
13147	OE:46306526	25	25	6,90€
13148	OE:14591687	25	25	7,00€
13149	OE:14592387	25	25	6,10€
13150	OE:83468473	30	30	4,80€
13151	OE:7677865	50	30	11,90€



INFORMAÇÕES TÉCNICAS



52901

35,00€

0.48 6 24 216



SORTIMENTO DE CLIPS PARA VOLVO 350 PCS

REF.	DESCRIÇÃO			€/△
13152	OE:8099905N07	25	25	6,90€
13153	OE:4292906	30	30	6,60€
13154	OE:12681763	20	20	7,20€
13155	OE:51131804205	40	40	12,60€
13156	OE:947098	40	40	7,20€
13157	OE:591740	40	40	8,50€
13158	OE:6384801G00	25	25	7,90€
13159	OE:9133417	20	20	6,20€
13160	OE:9133073	40	40	11,20€
13161	OE:3272075327462B	30	30	7,90€
13162	OE:327462A	20	20	5,90€
13163	OE:3923712	20	20	6,30€



INFORMAÇÕES TÉCNICAS



52889

19,00€

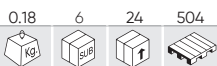

SORTIMENTO DE CLIPS PARA VOLKSWAGEN 85 PCS

REF.	DESCRIÇÃO			€/kg
13038	OE:1H0868243B	2	2	2,85€
13039	OE:N90833801	10	10	2,95€
13040	OE:3A0853575	8	8	3,90€
13041	OE:4A0853825	5	5	3,50€
13042	OE:6U085733	15	15	4,05€
13043	OE:3B0853576	3	3	2,65€
13044	OE:1H0819055B01C	6	6	3,40€
13045	OE:443853909A	5	5	2,60€
13046	OE:171885767	6	6	3,40€
13047	OE:N9020160H	5	5	2,75€
13048	OE:N0385501	10	10	3,70€
13049	OE:191941142	10	10	4,45€



52891

28,00€

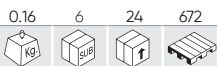

SORTIMENTO DE CLIPS PARA FORD 169 PCS

REF.	DESCRIÇÃO			€/kg
13056	OE:388577S	8	8	3,20€
13057	OE:N801925S	5	5	3,30€
13058	OE:N806289S	20	20	4,75€
13059	OE:N379830S	20	20	5,20€
13060	OE:1007932	5	5	2,65€
13061	OE:16500308	20	20	5,50€
13062	OE:N803170S	20	20	5,20€
13063	OE:W706713S300	6	6	2,45€
13064	OE:N388246S	20	20	5,70€
13065	OE:F22216774A	15	15	4,30€
13066	OE:1673046	5	5	4,00€
13067	OE:FICZ16674A	25	25	5,60€

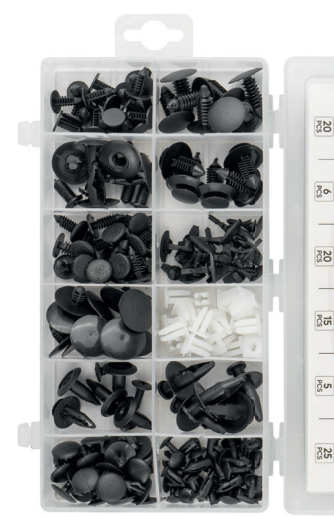

52894

22,00€

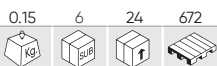

SORTIMENTO DE CLIPS PARA NISSAN 139 PCS

REF.	DESCRIÇÃO			€/kg
13080	OE:76906T300	15	15	3,70€
13081	OE:0155300172	20	20	5,10€
13082	OE:68425H5000	10	10	2,95€
13083	OE:75521611000	6	6	2,95€
13084	OE:62869N4700	20	20	4,40€
13085	OE:6384401A00	5	5	2,95€
13086	OE:7688257A00	5	5	2,85€
13087	OE:6684101G00	25	25	7,30€
13088	OE:1099830880	10	10	5,10€
13089	OE:8942798070	10	10	3,20€
13090	OE:6384801G00	8	8	3,80€
13091	OE:6385401A00	5	5	2,75€



52890

22,00€

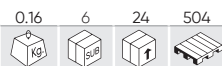

SORTIMENTO DE CLIPS PARA AUDI 31 PCS

REF.	DESCRIÇÃO			€/box
13050	OE:3B0868243	5	15	3,90€
13051	OE:1H0867199A	5	20	2,75€
13052	OE:1H0868243B	3	3	2,65€
13053	OE:357853575	10	10	5,70€
13054	OE:1H0853585A	5	5	5,20€
13055	OE:3A0853575	3	3	6,80€



INFORMAÇÕES TÉCNICAS



52892

22,00€



SORTIMENTO DE CLIPS PARA BMW 95 PCS

REF.	DESCRIÇÃO			€/box
13068	OE:51311802258	25	25	6,00€
13069	OE:5131804205	30	30	9,90€
13070	OE:51118174185	10	10	3,50€
13071	OE:51481938725	10	10	3,80€
13072	OE:703867299	15	15	4,85€
13073	OE:51131960054	5	5	4,75€



INFORMAÇÕES TÉCNICAS



52897

38,00€

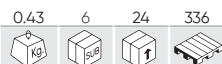

SORTIMENTO DE CLIPS PARA RENAULT 300 PCS

REF.	DESCRIÇÃO			€/box
13116	OE:7703077421	50	50	11,90€
13117	-	50	50	7,70€
13118	OE:7703081184	60	60	36,50€
13119	-	15	15	12,90€
13120	OE:7703074022	60	60	11,90€
13121	OE:7703077059	65	65	19,30€



INFORMAÇÕES TÉCNICAS



52898

36,00€

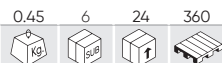

SORTIMENTO DE CLIPS PARA VAUXHALL / OPEL 300 PCS

REF.	DESCRIÇÃO			€/box
13122	OE:90218614	20	20	4,30€
13123	OE:174864	40	40	10,50€
13124	OE:N0385501	100	100	18,30€
13125	OE:2345959	50	50	11,00€
13126	OE:2240582	50	50	5,30€
13127	OE:180942	40	40	12,60€



INFORMAÇÕES TÉCNICAS



52893

26,00€

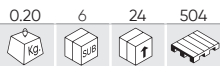

SORTIMENTO DE CLIPS PARA BENZ 95 PCS

REF.	DESCRIÇÃO			€/kg
13074	OE:A0019884481	30	30	9,80€
13075	OE:A0019882981	20	20	11,90€
13076	OE:A1249900492	15	15	7,20€
13077	OE:A0019888081	4	4	5,80€
13078	OE:A1249880492	6	6	5,80€
13079	OE:A0019880325	20	20	7,20€



INFORMAÇÕES TÉCNICAS



52895

22,00€

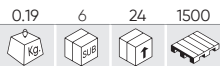

SORTIMENTO DE CLIPS PARA MITSUBISHI 134 PCS

REF.	DESCRIÇÃO			€/kg
13092	OE:8942180270	15	50	3,55€
13093	OE:9018905013	30	30	6,30€
13094	OE:MU480033	10	10	3,25€
13095	OE:128100231	8	6	2,75€
13096	OE:MU480034	8	8	3,80€
13097	OE:MR138807	3	3	2,65€
13098	OE:MB253964	4	4	3,50€
13099	OE:HB121467	30	30	5,80€
13100	OE:MB271999	3	3	2,75€
13101	OE:MB696120	8	8	3,20€
13102	OE:MR200300	5	5	2,65€
13103	OE:MB846992	10	10	3,90€



INFORMAÇÕES TÉCNICAS



52888

24,00€

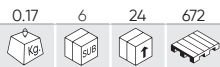

SORTIMENTO DE CLIP UNIVERSAL 128 PCS

REF.	DESCRIÇÃO			€/kg
13026	OE:388577S	8	8	2,65€
13027	-	10	10	4,00€
13028	OE:6003423	6	6	2,85€
13029	OE:VW:N989022 CHRYSLER: 6003349 FORD:385661	6	6	3,50€
13030	OE:CHRYSLER: 6502328 GM:20699808	25	25	5,90€
13031	OE:N804379S	4	4	3,80€
13032	OE:FORD:F2221674A MAZDA:6508197AA	15	15	4,35€
13033	OE:GM:16674629 FORD:N806113S	10	10	3,60€
13034	OE:0153301781	20	20	5,80€
13035	OE:GM:10124502 BMW:52201964201 LAND ROVER:D2M10080	6	6	3,05€
13036	OE:VW:N9020160H BMW:51471904317 OPEL:2207713	6	6	2,65€
13037	-	12	12	4,30€



INFORMAÇÕES TÉCNICAS



53720

19,00€

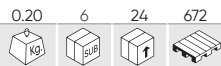

SORTIMENTO DE 112 PÇS DE CLIPES PARA TAPEÇARIA DE BMW MINI

REF.	DESCRIÇÃO			€/△
14447	OE: 51471911992	7	6	2,75€
14449	OE: 51717002953	13	10	4,85€
14471	OE: 51489119216	5	5	4,35€
14472	OE: A0009905492	5	5	3,00€
14474	OE: 51118174185	8	8	3,40€
14475	OE: 2019900050	6	6	3,70€
14476	OE: 51481915964	9	9	4,65€
14477	OE: 0009881625	15	15	5,70€
14478	OE: 7146976114	15	15	9,40€
14479	OE: 91503SP0003	6	6	3,70€
14480	-	15	15	4,65€
14481	OE: 51161943122	8	8	3,60€



53719

19,00€

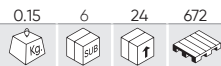

SORTIMENTO DE CLIPES PARA PAINÓS DE PORTA / MOLDURAS

REF.	DESCRIÇÃO			€/△
14359	-	8	8	2,05€
14458	-	6	6	3,80€
14459	OE: 7147122912	2	2	3,20€
14460	OE: 51411973500	8	8	2,45€
14461	-	8	8	3,00€
14462	-	8	8	3,70€
14463	OE: 611769	10	10	3,70€
14464	OE: 7147145753	10	10	3,40€
14465	-	8	8	4,55€
14466	OE: 51418224768	8	4	3,70€
14468	-	8	8	2,85€
14469	OE: 7147133419	8	8	3,30€



53718

19,00€

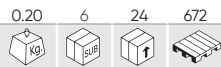

SORTIMENTO DE 151 PÇS DE CLIPES PARA TAPEÇARIA DE MERCEDES-BENZ

REF.	DESCRIÇÃO			€/△
14422	OE: A0009913940	20	20	3,40€
14446	OE: 9903492	6	6	6,40€
14447	OE: 51471911992	12	12	2,75€
14448	OE: N105835019B9	10	10	4,65€
14449	OE: A0009905492	12	12	4,85€
14450	OE: N0385012	12	12	4,85€
14451	OE: A1239900092	25	25	4,85€
14452	-	20	20	5,90€
14453	-	6	6	7,00€
14455	-	12	12	4,85€
14456	-	6	6	3,00€
14457	OE: A1249900492	10	10	3,80€



53717

19,00€

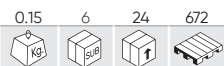

SORTIMENTO DE 96 PÇS DE CLIPES PARA PAINÉIS DE PORTA/MOLDURAS DE MERCEDES-BENZ

REF.	DESCRIÇÃO			€/∆
14434	-	8	8	3,40€
14435	-	6	6	3,30€
14436	OE: A0009910198	8	8	3,80€
14437	OE: A0019912698	6	6	3,30€
14438	OE: A0089880978	8	8	3,00€
14439	OE: 0069884378	8	8	3,90€
14440	-	8	8	3,90€
14441	OE: 0019884981	10	10	3,70€
14442	-	6	6	3,30€
14443	-	8	8	3,20€
14444	OE: 0019886081	10	10	4,35€
14445	-	10	10	3,20€



INFORMAÇÕES TÉCNICAS



53716

19,00€



SORTIMENTO DE 79 PÇS DE CLIPES PARA PAINÉIS DE PORTA/MOLDURAS/TAPEÇARIA DE VAG/SEAT/SKODA

REF.	DESCRIÇÃO			€/∆
14422	OE: A0009913940	6	6	3,40€
14423	OE: 6E0837732	15	15	8,30€
14424	-	7	7	4,20€
14425	OE: 6Q0868243	2	2	4,10€
14426	OE: 171201969	8	8	4,35€
14427	OE: 4D0807300	8	4	2,65€
14428	OE: 251823717	12	12	3,10€
14429	-	6	6	4,10€
14430	OE: 8E0821989A	3	3	5,20€
14431	OE: 3B0868243	2	2	3,20€
14432	OE: 1H0823171	10	10	3,20€



INFORMAÇÕES TÉCNICAS



53715

19,00€

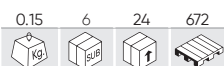

SORTIMENTO DE 110 PÇS DE CLIPES PARA TAPEÇARIA DE PEUGEOT/CITROËN

REF.	DESCRIÇÃO			€/∆
14410	-	10	10	3,80€
14411	-	10	5	3,80€
14412	-	10	10	3,80€
14413	-	10	10	7,60€
14414	OE: 2346824	10	10	3,80€
14415	OE: A1249900492	10	10	3,70€
14416	OE: 6992C6	10	5	2,45€
14419	-	15	15	4,45€
14420	-	15	15	3,40€
14421	OE: 14093311	10	10	5,70€



INFORMAÇÕES TÉCNICAS



53714

16,00€

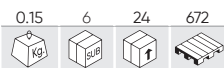

SORTIMENTO DE 80 PÇS DE CLIPES PARA MOLDURAS DE PEUGEOT/CITROËN

REF.	DESCRIÇÃO			€/∆
14398	OE: 6995X3	8	8	2,85€
14399	OE: 129943	12	6	4,35€
14402	OE: 856548	8	8	3,00€
14404	OE: 71728806	8	8	4,35€
14405	OE: 968865987703	16	8	3,20€
14406	OE: 856540	10	10	3,50€
14408	OE: 856534	10	10	3,20€
14409	OE: 357853586	8	8	3,00€



INFORMAÇÕES TÉCNICAS



53713

16,00€



SORTIMENTO DE 93 PÇS DE CLIPES PARA PAINÉIS DE PORTA DE PEUGEOT/H16CITROËN

REF.	DESCRIÇÃO			€/∆
14350	OE: 6991Y8	6	6	3,70€
14358	OE: PG 6991Y8 CT 6991Y8 FIAT 9654280780 RENAULT 703077469	10	10	4,10€
14387	-	8	8	3,20€
14388	OE: 7703077250	8	8	4,65€
14389	OE: 6995A3	6	6	2,75€
14390	-	6	6	3,00€
14391	-	15	15	4,95€
14392	-	6	6	3,00€
14393	-	8	8	3,40€
14395	-	8	8	3,70€
14396	-	6	6	2,55€
14397	-	6	6	3,00€



INFORMAÇÕES TÉCNICAS



53712

16,00€

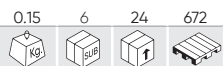

SORTIMENTO DE 109 PÇS DE CLIPES DE ESTOFADO PARA TAPEÇARIA DE RENAULT DACIA

REF.	DESCRIÇÃO			€/∆
14374	OE: 7703077435	3	3	3,30€
14375	-	15	15	4,20€
14376	OE: 7L6868307	20	20	6,00€
14377	-	10	10	4,35€
14378	OE: 7703077117	12	12	4,35€
14379	-	6	6	3,30€
14381	-	10	10	3,80€
14382	OE: 7703077153	6	6	4,20€
14383	OE: 7703072360	10	10	2,35€
14384	OE: W705956S300	12	12	4,55€
14416	OE: 6992C6	5	5	2,45€



INFORMAÇÕES TÉCNICAS



53711

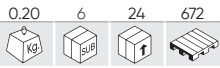

SORTIMENTO DE 90 PÇS DE CLIPES PARA MOLDURAS+H13 DE RENAULT DACIA

REF.	DESCRIÇÃO	10	10	€/△
14356	OE: RENAULT 7703077368 OPEL 4430858	10	10	4,35€
14358	OE: PG 6991Y8 CT 6991Y8 FIAT 9654280780 RENAULT 703077469	12	10	4,10€
14364	OE: OP 7701470779 NI 7703077421 RENAULT 7703077421 IV 500326896	10	10	4,35€
14365	OE: OP 7701470779 NI 7703077421 RENAULT 7703077421 IV 500326896	10	10	4,35€
14366	OE: PG 6991Y8 CT 6991Y8 FIAT 9654280780 RENAULT 703077469	8	8	3,20€
14367	-	3	3	2,85€
14368	OE: 7703077476	8	8	3,20€
14369	OE: 7701061797	15	15	11,60€
14370	-	3	3	6,90€
14371	-	3	3	6,90€
14372	-	4	4	2,65€
14373	-	4	4	3,00€



INFORMAÇÕES TÉCNICAS



53710

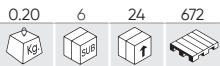

SORTIMENTO DE 85 PÇS DE CLIPES PARA PAINÉIS DE PORTA DE RENAULT DACIA

REF.	DESCRIÇÃO	12	6	€/△
14350	OE: 6991Y8	12	6	3,70€
14351	-	8	15	3,70€
14352	OE: 51447780135	7	7	2,85€
14353	OE: 7703077476	8	2	4,75€
14355	OE: 7703077354	8	8	3,80€
14356	OE: RENAULT 703077368 OPEL 4430858	10	4	4,35€
14357	OE: 7703077430	10	12	4,35€
14358	OE: PG 6991Y8 CT 6991Y8 FIAT 9654280780 RENAULT 703077469	10	6	4,10€
14359	OE: 51418224768	4	3	2,05€
14361	-	8	15	3,80€



INFORMAÇÕES TÉCNICAS



16294

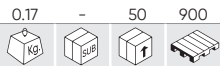

PÔSTER DE CLIPS TAMANHO REAL

Peças	1
Material	Papel plastificado/Laminated paper
Peso	0,17Kg
Dimensões (CxX)	1000x640mm

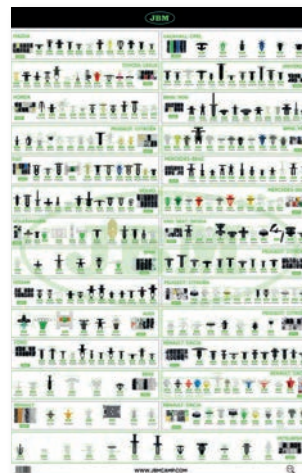

TAMAÑO REAL DE LOS CLIPS
CLIPS REAL SIZE

PROMOCIONAL

454 PRODUTOS PROMOCIONAIS

456 ECRÃS / ACESSÓRIOS

457 ROUPAS DE TRABALHO

458 EMBALAGEMS



53956

353,00€

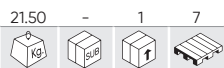

CADEIRA GIRATÓRIA



REPOSIÇÕES DISPONÍVEIS

Material	PU
Capacidade	200Kg
Peso	21,50Kg
Dimensões (CxLxA)	840x650x330mm

15789

2.492,00€

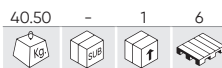

EXPOSITOR DIGITAL DO DISTRIBUIDOR JBM



Tamanho do painel	43"
Resolução	1920x1080FHD
Brilho	350nits
Tempo de resposta	5ms
Vida útil	50000h
Peso	40,50Kg
Dimensões (CxLxA)	610x450x1850mm

53973

284,00€

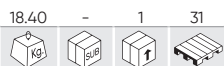

TENDA FOLDABLE JBM 3X3M



REPOSIÇÕES DISPONÍVEIS

Material	PL
Peso	18,40Kg
Dimensões (CxLxA)	3x3x3m

15152

160,00€



LATERAL P/CARPA STAND JBM 3X3M REF. 53973



Material	PL
Peso	0,75Kg
Dimensões (CxLxA)	495x360x60mm

54506

46,50€

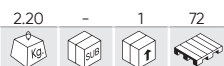

BANDEIRA PUBLICITÁRIA JBM 3M



Comprimento	3m
Peso	2,20Kg

54507

74,00€



BANDEIRA PUBLICITÁRIA JBM 5M



Comprimento	5m
Peso	2,80Kg

54672

189,00€

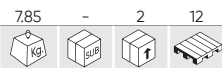

FRITADEIRA DE AR DIGITAL DUPLA 9L



REPOSIÇÕES DISPONÍVEIS



Capacidade	9L
Número de predefinições	8
Potência	1800W
Tensão	220-240V
Temperatura de trabalho	80-200°C
Peso	7,20Kg
Dimensões (CxLxA)	420x383x316mm

54889

135,00€

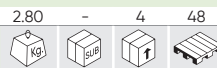

NEW

CAFETEIRA DE CÁPSULAS



Compatível com	Cápsulas monodosis/Single-dose capsules
Extração	Espresso / Lungo
Pressão máxima	20Bar
Tensão	220-240V
Frequência	50Hz
Potência	1350W
Peso	2,50Kg
Dimensões (CxLxA)	330x116x228mm

14975

70,00€



SUPORE DE PRESUNTO



Peso	2,95Kg
Dimensões (CxLxA)	500x330x440mm

13968

1,35€

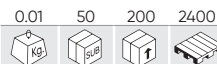

SACO JBM PUBLICIDADE



Peso	0,01Kg
Dimensões (CxLxA)	350x250x1mm

54278

4,50€

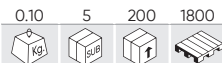

TAMPA JBM



Material	CO
Peso	0,10Kg
Dimensões (CxLxA)	200x170x90mm

54325

29,00€

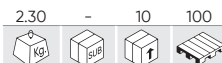

TAPETE 100X65CM



Material	PL, PVC
Peso	2,30Kg
Dimensões (CxL)	1000x650mm

54480

1,10€

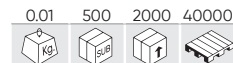

CHAVE DE IGNIÇÃO JBM



Material	PL
Diâmetro	30mm
Peso	0,10Kg
Dimensões (CxL)	100x30mm

14807

11,30€

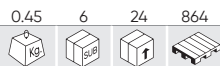

SELO DE GARANTIA JBM



Material	PP
Espessura	28µm
Idiomas	Multidioma/Multi language
Peso	0,45Kg
Dimensões (CxL)	125x75mm

16900

11,00€

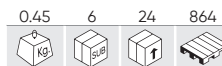

SELO DE GARANTIA JBM



Material	PP
Espessura	28µm
Idiomas	Multidioma/Multi language
Peso	0,45Kg
Dimensões (CxL)	125x75mm

53914

82,00€

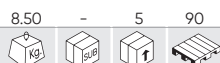

POSTE DE SEPARAÇÃO COM FITA RETRACTIL



Material	S
Altura	3m
Tubo	63mm
Diâmetro	320mm
Peso	8,50Kg

Vendido individualmente. Compre a quantidade necessária para delimitar o seu espaço.

53492

380,00€



EXPOSITOR DE FERRAMENTA PNEUMÁTICA



Peso	13,00Kg
Dimensões (CxLxA)	970x530x240mm

GANCHO

REF.	TIPO	mm					€
14034		106mm	0.20	20	80	1920	9,00€
14623		84mm	0.10	-	10	800	8,00€
14626		115mm	0.10	-	10	-	7,00€
11318		100mm	0.04	20	600	14400	2,50€
16364		280mm	0.20	10	200	9999	3,50€
51315		100mm	0.02	20	320	44800	2,50€

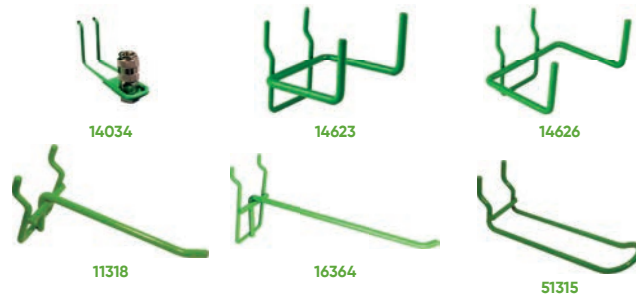

BANDEJA

REF.	TIPO	mm					€
14622		320mm	0.95	-	10	360	18,00€
14624		290mm	0.65	-	10	300	18,00€
14625		200mm	0.50	-	10	700	14,00€

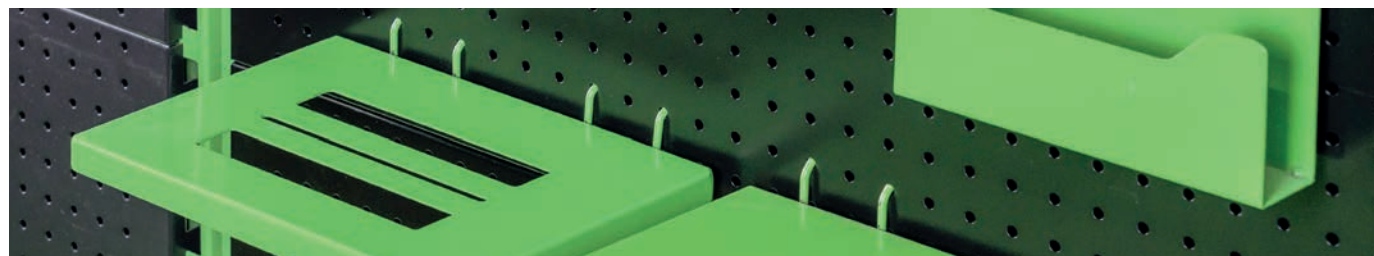
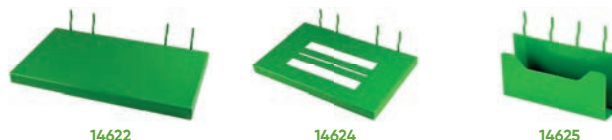

53877**430,50€****EXPOSITOR DE FERRAMENTAS****CONTÉM**

REF.	PCS	DESCRIÇÃO					€
14945	1	ESTANTE DE FERRAMENTAS-BASE	37.80	-	1	16	338,00€
14946	1	CABEÇAL PARA EXPOSITOR DE FERRAMENTAS	3.40	-	1	54	58,00€
14380	1	BANDEJA DE SUPORTE DE FERRAMENTAS 53877	5.00	-	1	34	61,00€
11318	20	GANCHO PONTA COMPRIDA	0.04	20	600	14400	2,50€

**53878****574,00€****FERRAMENTA EXPOSITOR + CABEÇA COM ILUMINAÇÃO****CONTÉM**

REF.	PCS	DESCRIÇÃO					€
14945	1	ESTANTE DE FERRAMENTAS-BASE	37.80	-	1	16	338,00€
14947	1	SUPORTE LEVE DE ESTANTE DE FERRAMENTAS	8.55	-	1	7	215,00€
14380	1	BANDEJA DE SUPORTE DE FERRAMENTAS 53877	5.00	-	1	34	61,00€
11318	20	GANCHO PONTA COMPRIDA	0.04	20	600	14400	2,50€

**COLETE JBM**

REF.						€
70001	M	0.30	-	5	200	35,00€
70002	L	0.40	-	5	200	35,00€
70003	XL	0.40	-	5	200	35,00€

CAMISETA JBM

REF.						€
70020	S	0.20	5	50	800	12,00€
70021	M	0.20	5	50	800	12,00€
70022	L	0.20	5	50	800	12,00€
70023	XL	0.20	5	50	800	12,00€
70024	XXL	0.20	5	50	800	12,00€
70025	XXXL	0.20	5	50	800	12,00€

13929

3,85€

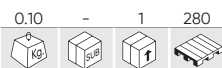

GANCHO DE VESTUÁRIO



Comprimento	490mm
Peso	0,10Kg



CAIXA DE PAPELÃO JBM

CAIXA DE FERRAMENTAS MANUAIS DE REPOSIÇÃO

REF.	DESCRIÇÃO				€
14922	CAIXA DE FERRAMENTAS DE MÃO PARA PEÇAS 14,5X9X10CM	0.10	100	-	1,65€
14923	CAIXA DE FERRAMENTAS MANUAIS DE REPOSIÇÃO 17.5 X 9 X 7 CM	0.10	100	-	1,65€
14924	CAIXA DE FERRAMENTAS DE MÃO PARA PEÇAS 24X11X7CM	0.10	100	-	1,65€
14925	CAIXA DE FERRAMENTAS DE MÃO PARA PEÇAS 31,5X13X4CM	0.10	100	-	1,65€
14926	CAIXA DE FERRAMENTAS DE MÃO PARA PEÇAS 32X8,5X7CM	0.10	100	-	1,65€



CAIXA PROMOCIONAL

REF.	DESCRIÇÃO				€
13717	CAIXA PARA PRESUNTO 76X14X29CM	0.90	1	200	11,90€
14083	CAIXA DE CARTÃO VERDE PROMO JBM 80X28X49CM	1.80	1	100	20,50€
14976	CAIXA DE CARTÃO DE PUBLICIDADE 80X31X61 CM	2.20	1	80	29,50€
15056	CAIXA DE CARTÃO DE PUBLICIDADE, 40X30X61 CM	1.60	1	70	18,10€



CAIXA JBM

REF.	DESCRIÇÃO				€
11330	PEQUENA CAIXA DE CARTÃO JBM 19X10X11CM (FOLES)	0.05	200	2400	0,86€
12950	CAIXA DE CARTÃO JBM 60X40X30CM	0.80	15	75	5,90€
12952	CAIXA DE CARTÃO JBM 40X30X20CM	0.40	20	240	2,90€
13217	CAIXA DE CARTÃO JBM 57X30X25CM (KITS DE EMERGÊNCIA)	0.55	15	150	4,05€
14974	CAIXA DE CARTÃO JBM 54X24X40CM (20 KITS DE FOLIOS)	0.65	20	240	5,10€
15051	CAIXA DE CARTÃO 40X32X30 CM	0.40	20	160	2,75€
14189	CONTAINER DE PALLET AMERICANO DE TRIPLO CANAL	10.00	1	40	87,00€
14507	CONTAINER DE PALLET EUROPEU	8.00	1	40	73,00€



INDICE NUMERICO

REF.	PÁGINA
10000	174
10054	283
10055	283
10735	112
10750	174
10751	174
10771	174
10923	174
11107	174
11121	208
11122	208
11123	208
11124	208
11125	208
11126	207
11127	207
11128	207
11129	207
11130	207
11131	207
11132	207
11133	207
11134	207
11135	207
11136	207
11137	207
11138	207
11139	207
11140	207
11141	207
11142	207
11143	207
11144	207
11145	207
11146	207
11147	207
11148	207
11149	207
11150	207
11151	207
11152	207
11153	207
11154	207
11155	207
11156	207
11157	207
11158	207
11159	207
11160	207
11161	207
11162	207
11163	207
11164	207
11165	207
11166	207
11167	207
11168	207
11169	207

REF.	PÁGINA
11170	207
11171	207
11172	207
11173	207
11174	207
11175	207
11176	207
11177	207
11178	207
11179	207
11180	207
11181	207
11182	207
11183	207
11184	207
11185	207
11186	207
11187	207
11188	207
11189	207
11190	207
11191	207
11192	207
11193	207
11194	207
11195	208
11314	207
11315	207
11316	207
11318	456, 457
11324	174
11325	174
11330	458
11613	208
11614	208
11615	208
11616	208
11617	208
11618	208
11619	208
11621	207
11622	207
11623	207
11624	208
11625	208
11628	207
11890	409
11891	409
11922	408
11938	206
11990	206
11994	112
11996	112
11997	112
11998	112
12009	193
12029	269
12030	269

REF.	PÁGINA
12061	208
12062	208
12063	208
12064	208
12065	208
12066	208
12067	208
12068	208
12069	208
12070	208
12071	208
12072	208
12074	206
12075	206
12937	206
12950	458
12952	458
12977	267
12984	208
12988	197
13002	444
13003	444
13004	444
13005	444
13006	444
13007	444
13008	444
13009	444
13010	444
13011	444
13012	444
13013	444
13014	444
13015	444
13016	444
13017	444
13018	444
13019	444
13020	444
13021	444
13022	444
13023	444
13024	444
13025	444
13026	448
13027	448
13028	448
13029	448
13030	448
13031	448
13032	448
13033	448
13034	448
13035	448
13036	448
13037	448
13038	446
13039	446

REF.	PÁGINA
13040	446
13041	446
13042	446
13043	446
13044	446
13045	446
13046	446
13047	446
13048	446
13049	446
13050	447
13051	447
13052	447
13053	447
13054	447
13055	447
13056	446
13057	446
13058	446
13059	446
13060	446
13061	446
13062	446
13063	446
13064	446
13065	446
13066	446
13067	446
13068	447
13069	447
13070	447
13071	447
13072	447
13073	447
13074	448
13075	448
13076	448
13077	448
13078	448
13079	448
13080	446
13081	446
13082	446
13083	446
13084	446
13085	446
13086	446
13087	446
13088	446
13089	446
13090	446
13091	446
13092	448
13093	448
13094	448
13095	448
13096	448
13097	448

REF.	PÁGINA
13098	448
13099	448
13100	448
13101	448
13102	448
13103	448
13104	444
13105	444
13106	444
13107	444
13108	444
13109	444
13110	444
13111	444
13112	444
13113	444
13114	444
13115	444
13116	447
13117	447
13118	447
13119	447
13120	447
13121	447
13122	447
13123	447
13124	447
13125	447
13126	447
13127	447
13128	445
13129	445
13130	445
13131	445
13132	445
13133	445
13134	445
13135	445
13136	445
13137	445
13138	445
13139	445
13140	445
13141	445
13142	445
13143	445
13144	445
13145	445
13146	445
13147	445
13148	445
13149	445
13150	445
13151	445
13152	445
13153	445
13154	445
13155	445

REF.	PÁGINA
13156	445
13157	445
13158	445
13159	445
13160	445
13161	445
13162	445
13163	445
13217	458
13226	71
13227	71
13228	71
13229	71
13230	71
13231	71
13232	71
13499	193
13500	193
13667	71, 109
13668	112
13680	205
13681	205
13682	205
13683	205
13689	205
13717	458
13723	207
13724	207
13725	207
13726	207
13727	207
13728	207
13729	207
13730	207
13731	207
13732	207
13733	207
13734	207
13735	207
13736	207
13738	408
13739	408
13745	207
13746	207
13748	207
13809	197
13810	197
13813	219
13814	219
13839	174
13879	408
13880	408
13929	458
13930	196
13931	196
13932	196
13933	196

REF.	PÁGINA
13934	196
13935	196
13936	196
13937	196
13938	196
13939	196
13968	455
13982	339
14031	174
14032	174
14033	174
14034	456
14075	196
14076	196
14077	196
14078	196
14081	373
14083	458
14114	112
14145	368
14146	368
14147	368
14148	368
14172	207
14173	207
14177	207
14178	207
14189	458
14190	196
14191	196
14192	196
14193	196
14195	197
14196	197
14197	197
14198	197
14199	197
14200	197
14201	196
14202	196
14203	196
14204	196
14205	196
14206	196
14207	196
14208	196
14209	196
14296	84, 86, 87, 90, 93, 97, 98, 103, 107
14297	84, 86, 87, 90, 93, 97, 98, 103, 107
14298	84, 86, 87, 90, 93, 97, 103
14299	84, 86, 87, 90, 93, 97, 103
14303	66
14314	197
14315	197
14327	100
14350	451, 452
14351	452
14352	452

REF.	PÁGINA
14353	452
14354	115
14355	452
14356	452
14357	452
14358	451, 452
14359	449, 452
14361	452
14364	452
14365	452
14366	452
14367	452
14368	452
14369	452
14370	452
14371	452
14372	452
14373	452
14374	451
14375	451
14376	451
14377	451
14378	451
14379	451
14380	457
14381	451
14382	451
14383	451
14384	451
14387	451
14388	451
14389	451
14390	451
14391	451
14392	451
14393	451
14395	451
14396	451
14397	451
14398	451
14399	451
14402	451
14404	451
14405	451
14406	451
14408	451
14409	451
14410	450
14411	450
14412	450
14413	450
14414	450
14415	450
14416	450, 451
14419	450
14420	450
14421	450
14422	449, 450
14423	450
14424	450
14425	450
14426	450
14427	450

REF.	PÁGINA
14428	450
14429	450
14430	450
14431	450
14432	450
14434	450
14435	450
14436	450
14437	450
14438	450
14439	450
14440	450
14441	450
14442	450
14443	450
14444	450
14445	450
14446	449
14447	449
14448	449
14449	449
14450	449
14451	449
14452	449
14453	449
14455	449
14456	449
14457	449
14458	449
14459	449
14460	449
14461	449
14462	449
14463	449
14464	449
14465	449
14466	449
14468	449
14469	449
14471	449
14472	449
14474	449
14475	449
14476	449
14477	449
14478	449
14479	449
14480	449
14481	449
14507	458
14534	194
14560	194
14561	197
14622	158, 456
14623	158, 456
14624	158, 456
14625	158, 456
14626	158, 456
14710	217
14711	217
14712	217
14713	217
14714	217

REF.	PÁGINA
14715	217
14728	208
14729	208
14730	208
14731	208
14732	208
14733	208
14734	208
14736	208
14737	208
14738	208
14739	208
14740	208
14741	208
14742	208
14743	208
14744	208
14745	208
14746	208
14747	208
14748	208
14793	429
14807	456
14837	134
14838	134
14839	134
14840	134
14841	134
14842	134
14893	138
14894	139
14895	138
14896	139
14897	138
14898	139
14899	138
14900	139
14922	458
14923	458
14924	458
14925	458
14926	458
14945	457
14946	457
14947	457
14950	147
14951	147
14952	147
14953	147
14974	458
14975	455
14976	458
14985	143
14986	142
14987	143
14988	143
14989	142
14990	143
14991	142
14993	142
14994	141
14995	141
15010	125

REF.	PÁGINA
15011	125
15012	125
15014	139, 138
15049	148
15051	458
15052	174
15056	458
15068	115
15069	115
15073	98
15076	98
15084	111, 244, 344
15122	40, 90, 109
15138	50
15139	50
15140	50
15147	50
15148	50
15149	50
15152	454
15155	90, 109
15156	39, 86, 109
15157	109
15158	86, 108
15159	108
15160	108
15161	86, 90, 108
15162	36, 111, 388
15313	115
15315	109
15316	41, 109
15375	216
15454	57, 109
15514	90, 110
15541	109
15631	339
15680	146
15681	86, 108
15682	146
15683	146
15684	146
15685	146
15686	146
15687	146
15688	146
15689	146
15706	65, 110
15730	94, 105
15731	94, 105
15732	94, 105
15733	94, 105
15734	94, 105
15735	94, 105
15736	86, 94, 105
15737	69, 111
15789	454
15799	110
15874	347
16052	174
16053	174
16111	64, 110
16161	116

REF.	PÁGINA
16162	116
16163	116
16294	452
16295	248
16309	266
16316	267
16344	115
16354	117
16355	117
16356	117
16357	117
16358	115
16359	115
16360	115
16361	115
16362	115
16363	115
16364	158, 456
16400	311
16490	81
16490B	81
16490G	81
16490K	81
16490O	81
16490P	81
16490R	81
16490S	81
16490Y	81
16491	82
16491B	82
16491G	82
16491K	82
16491O	82
16491P	82
16491R	82
16491S	82
16491Y	82
16492	80
16492B	80
16492G	80
16492K	80
16492O	80
16492P	80
16492R	80
16492S	80
16492Y	80
16493	80
16493B	80
16493G	80
16493K	80
16493O	80
16493P	80
16493R	80
16493S	80
16493Y	80
16494	82
16494B	82
16494G	82
16494K	82
16494O	82
16494P	82
16494R	82

REF.	PÁGINA
16494S	82
16494Y	82
16496	83
16497	83
16498	83
16500	79
16500B	79
16500G	79
16500K	79
16500O	79
16500P	79
16500R	79
16500S	79
16500Y	79
16516	83
16561	83
16569	208
16570	208
16600	83
16627	79
16627B	79
16627G	79
16627K	79
16627O	79
16627P	79
16627R	79
16627S	79
16627Y	79
16628	80
16628B	80
16628G	80
16628K	80
16628O	80
16628P	80
16628R	80
16628S	80
16628Y	80
16629	83
16718	208
16719	208
16720	208
16748	207
16749	207
16750	207
16776	118
16777	118
16778	118
16779	118
16780	118
16835	83
16836	83
16861	117
16865	117
16872	379
16873	91, 104
16874	91, 104
16875	91, 104
16876	91, 104
16877	91, 104
16878	91, 104
16879	91, 104
16900	456
17134	206

REF.	PÁGINA
17135	206
17136	206
17137	206
17138	89, 106
17139	89, 106
17141	85, 88, 89, 106
17142	85, 88, 89, 106
17143	89, 106
17144	85, 88, 89, 106
17543	156
17544	156
17545	156
17571	344
17605	376
17728	88, 107
17729	85, 107
17746	83
17747	83
17775	98, 107, 112
17797	79
17798	79
17799	79
17800	79
17801	79
17802	79
17803	79
17804	79
17805	79
17806	79
17807	79
17808	79
17809	80
17810	80
17811	80
17812	80
17813	80
17814	80
17815	80
17816	80
17817	80
17818	80
17819	80
17820	80
17821	80
17822	80
17823	80
17824	80
17825	80
17826	80
17827	81
17828	81
17829	81
17830	81
17831	81
17832	81
17833	82
17834	82
17835	82
17836	82
17837	82
17838	82

REF.	PÁGINA
17839	82
17840	82
17841	82
17842	82
17843	82
17844	82
17849	78
17850	78
17851	78
17852	78
17853	78
17854	78
17892	386
17919	83
17921	83
17954	78
17955	78
17958	79
17959	79
17962	79
17963	79
17964	80
17965	80
17966	80
17967	80
17968	81
17969	81
17970	82
17971	82
17972	82
17973	82
17974	80
17975	80
18037	77
18038	77
18039	77
18040	77
18041	77
18042	77
18043	77
18044	77
18090	127
18091	127
18092	127
18093	127
18094	127
18095	127
18100	127
18101	127
18102	127
18103	81
18103B	81
18103G	81
18103K	81
18103O	81
18103P	81
18103R	81
18103S	81
18103Y	81
18105	81
18105B	81
18105G	81
18105K	81

REF.	PÁGINA
18105O	81
18105P	81
18105R	81
18105S	81
18105Y	81
18179	81
18180	81
18181	81
18182	81
18183	81
18184	81
18185	81
18186	81
18189	81
18190	81
18191	81
18192	81
18193	81
18194	81
18195	81
18196	81
18258	401
18259	401
18295	128
18296	128
18299	128
18300	128
18301	128
18304	128
18306	401
18307	401
18357	118
18358	118
18359	118
18360	118
18361	118
18362	118
18363	118
18364	118
18365	118
18366	118
18368	344
18379	115
18463	89, 106
50400	412
50403	412
50409	413
50410	412
50431	404
50517	395
50518	395
50551	404
50562	39
50564	38
50567	59
50577	219
50585	405
50622	44
50630	364
50631	362
50632	379
50644	406
50651	440

REF.	PÁGINA
50652	440
50654	400
50656	226, 396
50717	406
50724	73
50751	191, 350
50787	125
50788	125
50789	124
50792	286
50793	286
50797	195, 393
50807	269, 439
50808	120
50815	352
50816	353
50818	352
50819	355
50820	355
50821	355
50822	355
50823	355
50824	355
50825	355
50827	271
50830	356
50831	361
50835	358
50836	363
50838	363
50839	222, 359
50840	362
50843	119
50844	119, 230
50852	350
50901	213
50902	56
50903	213
50910	172
50911	364
50913	226, 396
50915	404
50916	412
50917	342
50918	342
50923	222, 359
50924	344, 396
50935	342
50937	73
50942	372, 387
50957	123
50959	123
50966	400
50966C	400
50980	35
50982	35
50983	31
50985	31
51017	57
51018	57
51020	57
51021	57
51028	202

REF.	PÁGINA
51033	383, 393
51035	114
51050	123
51051	123
51059	233
51119	281
51120	256
51121	270
51123	280
51124	290
51125	289
51126	284
51127	53
51131	212
51210	180
51211	179
51212	179
51213	180
51214	181
51215	181
51216	184
51220	182
51222	178
51235	370
51238	368
51239	368
51245	184
51246	407
51253	342
51258	174
51259	282
51260	29
51262	53
51266	406
51272	65
51277	187
51283	235
51305	48
51306	48
51307	47
51315	456
51318	40
51326	164
51331	174
51332	240
51333	33
51336	205
51337	246
51338	53
51340	333
51341	193
51347	262
51349	290
51352	242
51353	242
51354	243
51355	62, 417
51356	347
51358	421
51359	421
51360	213
51361	213
51362	421

REF.	PÁGINA
51363	368
51364	270
51365	368
51368	279
51369	279
51383	187
51385	193
51386	193
51387	193
51398N	427
51405	47
51406	47
51409	33
51410	33
51412	406
51414	279
51416	420
51419	117
51420	117
51422	117
51443	193
51444	193
51445	193
51447	53, 110
51448	53, 110
51479	53
51488	320
51489	326
51490	280
51491	281
51493	251
51494	248
51495	281
51496	294
51500	294
51501	283
51504	66
51525	65
51526	65
51528	42
51538	437
51539	437
51540	437
51541	437
51542	437
51543	437
51544	437
51545	437
51546	437
51554	437
51573	164
51574	123
51575	122
51576	102
51600	122
51614	404
51615	404
51616	23
51622	226
51632N	427
51633	427
51634	427
51636N	427

REF.	PÁGINA
51638N	427
51640N	427
51642N	427
51653	117
51654	117
51655	117
51656	117
51657	117
51658	117
51659	44
51661	421
51674	66
51694	402
51696	402
51697	406
51703	408
51705	408
51706	414
51707	414
51708	414
51709	414
51710	414
51711	414
51712	414
51713	414
51714	414
51715	414
51716	414
51717	414
51718	414
51719	414
51720	414
51721	414
51722	414
51723	414
51724	414
51725	414
51726	414
51727	414
51737	113
51738	113
51741	419
51742	419
51743	419
51746	34
51751	360
51785	428
51795	45
51796	45
51797	45
51798	45
51799	437
51805	53, 110
51812	58
51814	418
51816	370
51818	19
51824	413
51831	383
51832	213
51837	380
51838	380
51839	238

REF.	PÁGINA
51843	437
51853	74
51855	23
51858	411
51861	189, 408, 409
51863	414
51864	41, 110
51886	173
51889	162
51890	46
51895	352
51896	285
51897	285
51898	285
51899	285
51901	358
51902	270
51905	355
51906	355
51907	355
51908	416
51909	68
51918	66
51919	298
51920	284, 441
51923	242
51927	260
51928	346
51934	242
51935	400
51936	400
51937	400
51951	74
51958	298
51960	169
51961	169
51962	169
51963	169
51964	168
51965	168
51966	169
51967	174
51968	174
51969	174
51972	62
51973	414
51975	117
51978	413
51980	188
51981	188
51982	394
51983	394
51984	394
51986	284
51989	74
51991	271
51995	60
51998	295
52010	288
52026	213
52027	432
52028	435

REF.	PÁGINA
52029	435
52030	437
52031	436
52032	435
52033	438
52043	434
52044	432
52049	69
52050	60
52052	59
52053	443
52054	443
52055	362
52056	298
52057	413
52058	413
52059	34
52060	34
52065	412
52066	264
52069	368
52070	368
52071	368
52076	259
52077	216
52148	120
52149	394
52152	63
52153	296
52158	436
52159	182
52160	183
52162	96, 383, 390
52163	437
52167	182
52169	56
52170	56
52171	184
52180	66
52181	66
52182	66
52183	66
52184	66
52185	66
52186	66
52190	262
52191	236
52197	48
52200	398
52202	396
52207	47
52227	272
52230	226, 395
52231	371
52233	370
52235	45
52236	45
52237	45
52238	45
52241	358
52242	348
52243	348
52244	413

REF.	PÁGINA
52259	406
52262	218
52263	218
52264	218
52265	218
52269	243
52270	273
52271	326
52272	60
52273	254
52275	237
52293	282
52295	218
52296	288
52297	288
52298	288
52302	171
52303	171
52304	355
52305	259
52310	427
52311	241
52312	241
52313	241
52314	241
52315	235
52316	283
52317	283
52319	281
52320	35
52321	219
52327	219
52329	340
52330	234
52337	200
52338	204
52339	202
52340	202
52341	201
52342	201
52343	204
52344	202
52345	200
52346	201
52347	204
52348	203
52349	46
52350	46
52351	46
52352	46
52353	46
52354	46
52355	46
52357	46
52358	46
52373	102
52375	168
52378	193
52381	187
52382	372, 387
52384	163
52385	220
52390	221

REF.	PÁGINA
52391	349
52412	61
52414	170
52415	170
52416	243
52417	243
52419	116
52420	116
52421	116
52422	256
52424	45
52425	66
52426	66
52427	66
52428	342
52430	429
52432	273
52433	73
52434	238
52439	371
52450	383
52453	347
52454	293
52455	238
52456	168
52460	66
52462	70
52463	70
52464	70
52466	125
52468	65
52472	65
52473	65
52474	221
52475	221
52476	221
52477	221
52478	221
52479	221
52480	221
52481	221
52482	221
52483	221
52484	221
52485	221
52486	221
52487	221
52488	252
52489	254
52490	186
52491	186
52494	278
52495	262
52497	227
52498	346
52500	54
52502	221
52503	221
52504	221
52505	221
52506	221
52507	221
52508	60

REF.	PÁGINA
52509	60
52511	221
52512	221
52514	360
52515	74
52518	241
52519	36, 388
52524	50
52525	50
52526	50
52527	183
52528	184
52530	405
52533	192, 214
52534	405
52535	405
52536	162
52540	190, 214
52541	271
52542	120
52543	191
52544	206
52545	206
52546	202
52547	200
52550	31
52551	289
52552	421
52565	66
52566	171
52567	171
52568	170
52569	170
52570	427
52571	427
52572	427
52573	427
52574	183
52575	72, 191
52583	73
52588	48
52589	218
52591	257
52592	257
52593	257
52595	70
52596	70
52597	70
52599	253
52600	386
52601	342
52603	28
52604	28
52605	28
52606	28
52607	243
52608	243
52609	71
52615	241
52616	333
52617	246
52619	60
52620	32

REF.	PÁGINA
52621	281
52624	293
52625	62, 238
52626	289
52627	289
52628	346
52629	250
52633	408, 409
52635	117
52636	232
52637	281
52638	73
52639	270
52640	278
52641	278
52642	279
52643	419
52644	408
52645	421
52646	421
52648	189
52649	420
52650	420
52652	418
52653	418
52655	420
52656	420
52657	419
52658	419
52659	419
52660	424
52662	418
52663	418
52664	424
52673	419
52675	186
52676	185
52677	243
52678	243
52685	254
52687	264
52690	261
52691	283
52692	364
52693	256
52694	200
52696	258
52697	258
52699	279
52700	74
52703	433
52711	433
52714	33
52715	33
52716	33
52717	33
52718	190
52719	437
52727	288
52728	288
52729	288
52730	288
52731	288

REF.	PÁGINA
52732	288
52733	288
52734	256
52735	197
52736	197
52737	197
52738	427
52739	427
52740	217
52749	223
52753	31
52754	259
52757	250
52758	186
52760	74
52761	64
52762	64
52765	218
52773	404
52774	404
52775	404
52781	404
52783	404
52786	67
52787	187
52788	213
52789	255, 346
52791	61
52794	73
52795	400
52796	298
52797	341
52798	186
52801	255
52802	295
52804	345
52805	345
52806	345
52807	345
52809	241
52810	201
52811	201
52812	60
52813	254
52814	179
52815	259
52816	282
52817	282
52819	292
52821	256
52822	281
52827	169
52828	169
52829	270, 409
52831	67
52832	261
52833	295
52834	208
52835	208
52836	217
52838	172
52839	173
52842	424

REF.	PÁGINA
52843	174
52845	363
52846	59
52847	59
52849	281
52850	261
52851	213, 443
52852	294
52858	249
52869	124
52870	124
52871	124
52873	73
52874	278
52875	278
52876	212
52877	68
52878	68
52879	68
52880	421
52881	421
52882	256
52884	370
52885	68
52886	444
52887	444
52888	448
52889	446
52890	447
52891	446
52892	447
52893	448
52894	446
52895	448
52896	444
52897	447
52898	447
52899	445
52900	445
52901	445
52902	386
52903	386
52904	73
52905	74
52906	234
52908	34
52909	34
52910	169
52912	41, 110
52913	51
52914	209
52915	209
52916	209
52917	209
52918	209
52919	209
52920	209
52921	209
52922	209
52923	209
52924	209
52925	209
52926	209

REF.	PÁGINA
52927	209
52928	209
52929	209
52930	210
52931	210
52932	210
52933	210
52934	210
52935	210
52936	210
52937	210
52938	210
52939	210
52940	210
52941	210
52942	210
52943	210
52944	210
52945	210
52952	372, 387
52953	183
52955	63
52956	63
52957	63
52958	63
52959	63
52960	63
52962	295
52963	263
52964	57
52965	57
52966	57
52967	57
52969	202
52977	214
52980	379
52982	62, 220
52985	361
52987	161
52991	348
52992	348
52998	218
52999	361
53001	263
53008	241
53009	250
53010	55
53017	40
53018	41
53025	72
53026	72
53027	72
53028	371
53029	371
53030	371
53031	124
53032	124
53033	411
53037	421
53038	421
53039	421
53041	285
53042	73

REF.	PÁGINA
53043	206
53045	172
53046	172
53047	170
53048	170
53049	171
53051	170
53052	171
53053	294
53054	287
53055	287
53056	290
53057	262
53058	290
53059	290
53060	201
53062	289
53063	193
53064	193
53065	193
53066	193
53067	193
53068	193
53069	250
53070	45
53071	45
53072	45
53073	45
53074	18
53077	205
53078	347
53079	223
53080	223
53081	52
53082	52
53083	69
53084	35
53086	287
53088	403
53089	403
53090	403
53092	403
53093	403
53095	69
53096	251
53108	21
53110	213, 443
53111	374
53112	352
53118	271
53119	256
53120	68
53121	68
53122	68
53124	222
53125	222
53126	224
53127	34
53129	292
53134	224
53137	184
53141	184
53144	346

REF.	PÁGINA
53145	374
53146	288
53147	192
53150	419
53151	173
53154	36, 388
53156	32
53159	25
53162	374
53165	36, 388
53166	384, 393
53167	384, 393
53168	384, 393
53178	404
53179	404
53180	404
53182	404
53183	404
53184	404
53187	348
53188	348
53189	382
53190	382
53191	126, 230
53192	126
53196	227
53197	205
53198	349
53202	191
53204	191
53205	187
53206	242
53207	295
53208	297
53209	371
53210	45
53211	120
53212	16
53214	345
53215	346
53216	162
53217	163
53218	358
53221	227
53224	212
53225	56
53226	414
53229	437
53230	216
53232	219
53235	244
53236	244
53237	244
53238	244
53240	285
53241	405
53246	364
53249	262
53250	290
53251	258
53256	416
53259	305
53260	305

REF.	PÁGINA
53261	305
53262	305
53263	305
53264	306
53265	306
53266	306
53267	306
53268	309
53269	307
53270	317
53271	318
53272	318
53273	318
53274	327
53275	327
53276	327
53277	327
53278	326
53279	327
53280	327
53281	328
53282	328
53283	328
53284	328
53285	328
53286	330
53287	331
53288	328
53289	320
53290	320
53291	321
53292	321
53293	313
53294	313
53295	313
53296	313
53297	316
53298	316
53299	322
53300	323
53301	323
53302	323
53303	301
53304	302
53305	323
53306	302
53307	323
53308	302
53309	302
53310	302
53311	320
53312	302
53313	310
53314	310
53315	331
53316	324
53317	324
53319	303
53320	329
53321	329
53324	314
53325	329
53326	329

REF.	PÁGINA
53327	329
53328	295
53330	256
53331	71
53332	71
53339	74
53340	437
53346	47
53348	432
53349	441
53350	432
53351	434
53352	438
53353	436
53354	435
53355	442
53356	442
53357	443
53358	438
53359	438
53360	434
53361	434
53362	435
53363	432
53364	432
53365	435
53366	435
53367	442
53368	442
53369	435
53370	441
53371	432
53372	432
53373	433
53374	441
53376	441
53377	436
53378	438
53380	442
53381	439
53382	433
53383	433
53384	280
53385	63, 443
53388	283
53389	58
53390	60
53391	284
53393	284
53394	272
53395	264
53396	61
53400	119
53401	119
53402	119
53403	119
53405	119
53406	119
53407	119
53408	119
53409	119
53410	262
53411	62

REF.	PÁGINA
53412	62
53414	375
53415	375
53416	189
53417	189
53418	189
53419	424
53420	42
53421	353
53422	352
53423	363
53426	255
53428	171
53429	171
53430	210
53434	440
53441	241
53444	27
53445	62
53449	189
53450	189
53452	324
53453	265
53456	266
53459	268
53463	293
53464	436
53468	50
53470	204
53472	246
53473	246
53474	285
53477	263
53478	50
53479	50
53480	50
53481	50
53484	373
53486	216
53487	62
53488	280
53489	255
53490	254
53492	192, 456
53499	266
53500	266
53501	250
53502	294
53503	383
53505	165
53506	165
53507	400
53508	411
53517	68
53518	347
53522	250
53523	321
53524	294
53525	215
53526	384, 392
53531	200
53532	195, 392
53536	173

REF.	PÁGINA
53539	267
53542	190, 424
53543	382
53545	212
53547	57
53548	57
53549	57
53550	57
53551	426
53552	426
53553	426
53561	411
53565	23
53566	341
53567	192, 214
53570	167
53572	191, 261
53573	182
53574	32
53575	56
53581	195, 392
53582	195, 392
53583	195, 392
53584	384, 392
53585	384, 392
53586	384, 392
53587	204
53588	177
53589	74
53590	360
53592	350
53593	191
53594	194
53595	194
53596	428
53597	428
53598	428
53599	268, 438
53605	423
53608	177
53609	336
53610	336
53611	186
53612	345
53613	72
53614	72
53615	72
53616	72
53617	72
53618	72
53620	112
53621	402
53623	402
53625	189
53626	185, 218
53627	341
53629	195
53630	195
53631	195
53632	195
53633	195
53634	195
53635	279

REF.	PÁGINA
53636	400
53637	261
53638	279
53639	45
53640	45
53641	45
53642	45
53643	45
53644	339
53645	338
53646	185
53648	331
53649	331
53650	251
53651	324
53652	287
53653	314
53654	43
53655	215
53656	377
53657	377
53658	377
53659	377
53660	377
53661	93
53662	258
53663	283
53664	292
53665	287
53666	287
53667	34
53668	34
53669	294
53670	243
53671	48, 112
53672	100
53673	217
53674	113
53675	220
53676	220
53677	220
53678	220
53681	179
53683	235
53684	360
53685	224
53686	93
53687	368
53688	368
53689	176
53690	168
53691	168
53693	408
53694	55
53695	408
53696	293
53697	336
53698	408
53701	287
53702	121
53703	121
53704	121
53705	412

REF.	PÁGINA
53706	330
53708	77, 78, 84, 87, 93, 97, 103
53710	452
53711	452
53712	451
53713	451
53714	451
53715	450
53716	450
53717	450
53718	449
53719	449
53720	449
53725	352
53726	176
53727	22
53728	22
53729	218
53733	178
53734	160
53735	244
53736	223
53737	44
53738	44
53739	44
53740	44
53742	272
53743	33, 206
53744	201
53745	409
53746	409
53747	409
53748	409
53749	409
53750	409
53751	409
53752	409
53753	409
53754	409
53755	409
53756	409
53757	409
53758	409
53759	409
53760	409
53761	92
53762	92
53767	93
53768	92
53769	95, 333
53770	95, 333
53771	95, 334
53772	95, 334
53773	95, 334
53774	95, 334
53775	95, 334
53776	161
53778	400
53779	357
53780	163
53782	121

REF.	PÁGINA
53784	181
53785	429
53786	430
53796	430
53808	430
53809	430
53811	430
53839	430
53845	357
53849	349
53850	134
53851	136
53852	136
53853	136
53854	136
53855	136
53856	136
53857	137
53858	137
53859	137
53860	137
53861	137
53862	429
53863	429
53864	417
53867	98
53868	84
53869	90
53870	90
53872	393
53873	344
53874	344
53875	292
53876	310
53877	457
53878	457
53880	359
53881	195, 392
53882	195, 392
53883	48
53884	48
53885	48
53886	48
53887	48
53888	48
53895	356
53896	356
53897	356
53898	356
53903	125
53904	93
53905	58
53906	58
53908	59
53909	59
53910	440
53911	59
53912	90
53913	90
53914	456
53915	30
53917	54
53919	410

REF.	PÁGINA
53921	227
53922	227
53927	369
53928	26
53929	369
53932	64
53939	84
53940	96, 390, 430
53942	96, 390, 430
53943	54, 109
53944	54, 109
53945	54, 109
53947	229, 381
53948	229, 381
53951	95, 334
53952	95, 334
53953	22
53954	44
53955	44
53956	454
53958	125
53964	411
53965	411
53967	59
53969	363
53972	51
53973	454
53976	63
53977	374
53978	233
53979	43, 111
53980	43, 111
53981	375
53982	375
53983	222
53984	426
53985	426
53986	426
53987	390, 430
53988	205
53992	441
53993	69
53997	253
53999	145
54000	145
54001	356
54002	145
54003	286
54004	163
54005	46
54006	92
54008	145
54010	145
54011	145
54013	401, 418
54015	59
54016	237
54017	214
54018	47
54019	47
54021	47

REF.	PÁGINA
54022	47
54023	47
54024	47
54028	49
54029	49
54030	49
54031	49
54032	40, 110
54033	261
54034	11
54035	12
54036	13
54037	14
54038	15
54039	165
54040	370
54041	39
54042	407
54042N	407
54044	173
54045	11
54046	12
54047	13
54048	14
54049	15
54050	343
54051	347
54053	386
54054	386
54055	386
54056	386
54057	386
54058	386
54059	386
54060	56
54061	56
54066	41, 110
54068	240
54069	269
54070	56
54071	56
54072	407
54073	410
54074	410
54078	174
54079	38
54080	121
54081	42
54082	17
54083	47
54084	47
54085	47
54086	47
54087	47
54088	165
54089	69
54090	21
54091	35, 387
54092	329
54093	35, 96, 111, 387, 390
54097	38
54098	45

REF.	PÁGINA
54099	69
54100	338
54101	41
54105	20
54106	19, 46
54108	18
54109	20
54110	40
54111	375
54112	64
54113	375
54114	96, 371, 388, 390
54115	42
54116	18
54117	40
54119	39
54120	38
54122	160
54123	160
54124	160
54125	382
54126	55
54129	96, 389, 390
54130	96, 388, 390
54131	388
54132	96, 389, 390
54133	165
54134	94, 105
54135	238
54136	424
54137	353
54139	265
54140	18
54141	30
54142	65
54143	357
54144	357
54145	357
54146	357
54147	357
54149	38
54150	38
54151	426
54152	426
54153	426
54154	29
54155	426
54156	426
54157	426
54158	111
54159	42
54160L	172
54160R	172
54161	172
54162	173
54163	172
54164	29
54166	410
54168	20
54169	410
54170	410

REF.	PÁGINA
54172	168
54173	168
54174	39
54175	366
54176	394
54177	426
54178	426
54179	426
54181	347
54182	347
54183	347
54184	347
54186	247
54187	43
54188	428
54189	428
54190	428
54191	428
54192	427
54193	427
54194	427
54195	427
54198	424
54199	332
54200	332
54201	314
54202	303
54203	303
54204	314
54205	325
54206	307
54207	317
54208	314
54209	315
54210	321
54211	303
54212	303
54213	311
54214	325
54215	303
54216	304
54217	325
54218	333
54219	307
54220	250
54221	325
54222	307
54223	315
54224	315
54225	321
54226	332
54227	307
54228	307
54229	381
54230	381
54231	381
54232	381
54233	96, 390
54234	96, 390
54235	96, 390
54236	96, 390
54237	94
54238	94

REF.	PÁGINA
54239	94
54240	94
54241	96, 389, 390
54246	216
54247	216
54248	188
54249	188
54250	10
54251	186
54252	152
54253	294
54254	64
54255	191, 349
54256	371
54257	358
54258	19
54260	315
54261	24
54262	398
54263	398
54264	398
54265	386
54266	29
54267	163
54269	52
54270	166
54271	166
54273	257
54274	257
54275	257
54277	20
54278	455
54279	61
54280	286
54288	311
54289	322
54290	343
54293	306
54295	99
54296	99
54297	99
54299	291
54302	54
54304	47
54305	398
54306	397
54308	397
54310	397
54311	61
54312	253
54313	136
54314	136
54316	203
54317	297
54318	258
54322	96, 390, 430
54323	311
54324	309
54325	455
54326	96, 390, 430
54328	114

REF.	PÁGINA
54329	419
54330	61
54331	68
54336	181
54338	42
54339	51
54340	177
54341	198
54342	379
54343	50
54344	164
54345	248
54346	137, 230
54347	258
54348	136
54349	365
54350	365
54351	365
54352	365
54353	365
54354	365
54355	365
54356	366
54357	365
54358	365
54359	366
54360	365
54361	365
54362	366
54363	365
54364	366
54365	365
54366	366
54367	343
54369	426
54370	426
54371	426
54372	237
54373	253
54374	121
54376	61
54379	162
54380	43
54381	283
54382	283
54383	283
54384	269
54386	364, 389
54388	101
54389	97
54390	438
54392	252
54393	123
54394	123
54395	123
54396	359
54397	178
54398	308
54399	308
54400	308
54401	308
54402	308

REF.	PÁGINA
54403	308
54404	309
54405	309
54406	309
54407	333
54408	330
54409	330
54410	330
54411	330
54412	332
54413	332
54414	319
54415	319
54416	319
54417	319
54418	319
54419	292
54420	313
54421	313
54422	316
54423	316
54424	314
54425	316
54426	317
54427	317
54428	318
54429	318
54430	304
54431	332
54432	311
54433	311
54434	325
54435	324
54436	325
54437	324
54438	321
54439	322
54441	305
54442	309
54444	304
54445	304
54454	326
54455	292
54457	292
54460	292
54462	312
54463	315
54464	315
54465	316
54466	331
54467	331
54471	301
54477	322
54479	61
54480	455
54481	43, 111
54482	376
54483	365
54484	365
54485	365
54486	365
54487	366
54488	365

REF.	PÁGINA
54489	366
54490	366
54491	366
54492	366
54493	365
54494	365
54495	366
54496	366
54497	366
54498	345
54499	102
54500	167
54501	95, 334
54502	95, 334
54503	97
54504	100
54505	67
54506	454
54507	454
54509	86
54510	88
54511	85
54512	378
54513	280
54514	192, 340
54516	354
54517	354
54518	99
54519	99
54520	99
54521	176
54522	378
54523	268
54524	373
54525	257
54526	53
54527	53
54529	52
54530	52
54531	44
54532	44
54533	53
54534	403
54535	99
54536	268
54537	99
54538	246
54539	30
54542	242
54543	242
54544	164
54545	34
54546	34
54547	176
54548	204
54551	55
54552	55
54554	382
54555	192, 340
54556	183, 227
54557	370
54558	346
54559	370

REF.	PÁGINA
54560	279
54561	374
54562	36, 388
54563	198
54564	364, 389
54565	266
54566	248
54567	160
54579	224
54581	423
54582	423
54583	119
54584	232
54585	69
54586	33, 132
54587	247
54588	235
54589	235
54590	255
54591	264
54592	312
54593	320
54594	312
54595	279
54597	361
54598	249
54599	161
54600	161
54601	161
54647	49
54648	49
54649	49
54655	416
54656	417
54657	417
54658	417
54659	417
54660	417
54661	417
54662	417
54663	417
54664	417
54665	417
54666	417
54667	417
54668	417
54669	417
54670	417
54671	417
54672	455
54673	417
54674	417
54675	417
54676	417
54677	349
54679	361
54681	395
54682	126, 230
54683	157
54684	54
54685	373
54688	91
54689	91, 104

REF.	PÁGINA
54690	91
54691	49
54694	49
54696	52
54697	58
54698	63
54699	67
54700	72
54701	72
54702	64
54703	68
54704	67
54705	67
54706	372
54707	373
54708	243
54709	59
54710	59
54711	58
54717	89
54718	89
54719	349
54720	89, 106
54721	237
54722	310
54723	86
54724	88
54725	85
54733	376
54734	206
54736	293
54738	318
54739	310
54740	248
54743	301
54744	317
54745	301
54746	326
54749	269
54750	249
54751	354
54753	378
54757	354
54758	115
54759	115
54760	401, 418
54761	366
54762	366
54763	366
54764	271
54768	247
54769	157
54770	177
54771	228, 380
54772	257
54777	63
54778	63
54779	63
54783	52
54784	118
54785	51
54786	353
54787	416

REF.	PÁGINA
54788	416
54789	226
54792	194
54793	194
54794	183
54795	377
54796	304
54800	260
54802	246
54804	122
54805	126, 167, 229
54806	200
54809	297
54810	296
54811	297
54812	297
54813	296
54814	297
54815	296
54816	297
54817	297
54818	296
54819	296
54820	296
54821	296
54822	296
54823	297
54824	263
54825	420
54826	252
54828	263
54829	275
54830	441
54831	322
54832	402
54833	402
54834	98
54835	402
54836	107
54839	102
54840	118
54841	118
54844	416
54845	260
54846	317
54847	251
54853	52
54854	9
54855	52
54857	52
54858	52
54859	178
54860	157
54861	265
54862	304
54863	8, 132
54865	198
54866	198
54867	198
54870	50
54872	378
54873	433

REF.	PÁGINA
54874	260
54875	337
54876	337
54877	336
54878	338
54879	339
54880	338
54881	337
54882	340
54883	378
54884	416
54885	416
54886	293
54887	238
54888	190
54889	455
54890	260
54891	312
54892	249
54893	323
54894	270
54895	230
54896	203
54897	278
54898	337
54899	320
54901	174
54902	174
54903	236
54904	401
54906	127
54907	127
54908	127
54909	127
54910	127
54911	420
54912	230
54913	402
54914	39
54916	354
54918	436
54929	436
54930	437
54931	437
54932	434
54933	434
54935	439
54936	439
54937	439
54938	433
54939	434
54940	442
54941	442
54942	442
54943	433
54944	439
54946	439
54947	312
54948	277
54949	319
54950	312
54951	261
54952	275

REF.	PÁGINA
54953	279
54954	289
54955	289
54956	259
54957	265
54958	280
54959	225
54960	225
54961	225
54962	225
54963	272
54964	422
54965	422
54967	166
54968	166
54970	423
54971	260
54975	245
54977	245
54978	245
54979	245
54980	245
54981	245
54983	245
54985	245
54986	245
54987	245
54988	245
54989	245
54990	245
54991	245
54992	245
54993	245
54994	245
54995	245
54996	245
55000	101
55001	101
55002	120
55003	278
55004	244
55005	203
55006	274
55007	265
55008	326
55010	67
55012	219
55013	255
55014	242
55015	284
55016	203
55017	369
55019	369
55020	369
55021	422
55022	422
55023	382
55025	228
55044	128
55045	128
55046	128
55047	128
55048	128

REF.	PÁGINA
55049	344
55051	237
55052	274
55053	275
55054	273
55055	276
55056	274
55057	275
55058	277
55059	273
55060	276
55061	276
55062	277
55063	277
55064	274
55065	276
55066	227
55067	275
55068	276
55069	277
55070	274
55071	276
55072	274
55073	277
55074	273
55075	275
55077	278
55078	291
55079	291
55080	291
55081	291
55082	292
55085	267
55087	403
55088	403
55089	403
55090	170
55092	251
55116	212
55117	87
55118	87
55135	362
55149	58
60001	147
60003	145
60003C	145
60004	148
60007	143
60007C	143
60009	140
60009C	140
60010	142
60010C	142
60011	142
60012	153
60013	153
60015	153
60016	153
60017	153
60019	141
60020	141
60022	143
60023	134

REF.	PÁGINA
60023C	134
60025	158
60026	158
60027	150
60029	151
60030	151
60031	151
60032	144, 215
60032C	144, 215
60033	141
60035	148
60037	145
60037C	145
60038	144, 350
60038C	144, 350
60039	151
60040	150
60041	146
60042	148
60043	147
60043C	147
60044	130
60044C	131
60045	152
60046	131
60046C	130
60047	135, 140
60047C	135
60048	130
60048C	131
60049	139, 140
60049C	139
60050	130
60050C	131
60051	130
60051C	131
60052	132
60052C	132
60053C	140
60054	138
60054C	138
60055	156
60056	156
60058	155
60058C	155
60059	154
60059C	154
60060	154
60060C	154
60061	156
60061C	156
60062	155
60062C	155
60063	152
60063C	152
60064	133
60064C	133
60065	149, 353
60066	153
60067	149, 236
60068	151
60069	153
60071	148, 228

REF.	PÁGINA
70001	457
70002	457
70003	457
70020	457
70021	457
70022	457
70023	457
70024	457
70025	457
90003	192
90004	192
JBMW-BEXP	409
SERIE124	408
SERIE446	78
SERIE446B	78
SERIE446G	78
SERIE446K	78
SERIE446O	78
SERIE446P	78
SERIE446R	78
SERIE446S	78
SERIE446Y	78
SERIE565	77
SERIE565B	77
SERIE565G	77
SERIE565K	77
SERIE565O	77
SERIE565P	77
SERIE565R	77
SERIE565S	77
SERIE565Y	77
SERIE587	77
SERIE587B	77
SERIE587G	77
SERIE587K	77
SERIE587O	77
SERIE587P	77
SERIE587R	77
SERIE587S	77
SERIE587Y	77
SERIE588	78
SERIE588B	78
SERIE588G	78
SERIE588K	78
SERIE588O	78
SERIE588P	78
SERIE588R	78
SERIE588S	78
SERIE588Y	78

